



सेंद्रल ट्रान्समिशन यूटिलिटी ऑफ इंडिया लिमिटेड

(पावर ग्रिड कॉर्पोरेशन ऑफ इंडिया लिमिटेड के स्वामित्व में)

(भारत सरकार का उद्यम)

CENTRAL TRANSMISSION UTILITY OF INDIA LTD.
(A wholly owned subsidiary of Power Grid Corporation of India Limited)
(A Government of India Enterprise)

Ref: CTU/W/00/2ndsitting_21st CMETS-WR

Date: 22.09.2023

As per distribution list

Subject: Minutes of the 2nd sitting of 21st Consultation Meeting for Evolving Transmission Schemes in Western Region (CMETS-WR) held on 29.08.2023-reg.

Sir,

Please find enclosed the minutes of 2nd sitting of 21st Consultation Meeting for Evolving Transmission Schemes in Western Region (CMETS-WR) held on 29.08.2023 through video conferencing.

The minutes are also available at our website (www.ctuil.in>>ISTS Planning and Coordination>>Consultation Meetings for ISTS).

Thanking you,

Yours faithfully,

(Partha Sarathi Das)
Sr. General Manager

Encl.: As stated above

Distribution List:

1. Chief Engineer (PSP&A – I) Central Electricity Authority Sewa Bhawan, R.K. Puram, New Delhi-110 066.	2. Director (Transmission/GEC) Ministry of New and Renewable Energy, Block 14, CGO Complex, Lodhi Road, New Delhi-110003
3. Member Secretary Western Regional Power Committee MIDC area, Marol, Andheri East, Mumbai 400 093	4. Director (Power System) Solar Energy Corporation of India Ltd. D-3, 1st Floor, A wing, Religare Building, District Centre, Saket, New Delhi-110017
5. Managing Director Gujarat Energy Transmission Corp. Ltd, Sardar Patel Vidyut Bhawan, Race Course, Vadodara -390 007	6. Director (Operation) Maharashtra State Electricity Transmission Co. Ltd., 4th Floor, “Prakashganga”, Plot No. C- 19, E-Block, Bandra – Kurla Complex, Bandra (East), Mumbai- 400051
7. Managing Director Chhattisgarh State Power Transmission Co. Ltd., Dangania, Raipur- 492 013	8. Chairman & Managing Director Madhya Pradesh Power Transmission Co. Ltd., Block No. 3, Shakti Bhawan, Rampur, Jabalpur-482 008
9. Executive Engineer Administration of Union Territory of Dadra & Nagar Haveli and Daman & Diu Secretariat, Moti Daman - 395 220	10. Chief Engineer Electricity Department The Government of Goa, Panaji
11. Executive Director Western Regional Load Despatch Centre Grid Controller of India Ltd. F-3, M.I.D.C. Area, Marol, Andheri East, Mumbai-400 093	12. Director (SO) Grid Controller of India Ltd. 9th Floor, IFCI Towers, 61, Nehru Place, New Delhi - 110019

Applicants/Participants:

<p>1. Sh. Ashish Shukla Senior General Manager Avaada Inclean Pvt. Ltd. C-11 Sector-65 NOIDA, Uttar Pradesh angshuman.rudra@avaada.com ashish.shukla@avaada.com</p>	<p>2. Shri Arzaan Dordi Chief Manager Serentica Renewables India 4 Pvt. Ltd., DLF Cyber Park, 9th Floor, Tower B, Sector-20 DLF Phase-3, Gurugram arzaan.dordi1@sterlite.com 9601775714</p>
<p>3. Sh. Pratyush Thakur Director Blue Leaf Energy Renewables Pvt Ltd Blue Leaf Energy, 01B-116, WeWork Roshni Tech Park, Marathahalli Main Road, Lakshminarayana Pura, EPIP Zone, Chinnapanna Halli, Bengaluru , BANGALORE URBAN, Karnataka 560037 livingston.emmanuel@blueleafenergy.com pratyush.thakur@blueleafenergy.com</p>	<p>4. Shri Sumit Joge DGM Business Development Sprng Vayu Vidyut Pvt. Ltd. Upper Ground Office A- 001 Pentagon-5, Magarpatta City Hadapsar, Pune, Maharashtra sumitjoge@sprngenergy.com 9545556456</p>
<p>5. Shri R.S. Surani Superintending Engineer [RE-2] Gujarat State Electricity Corporation Limited, Vidyut Bhavan, Race Course, Vadodara, Gujarat-390007 sere2.gsecl@gebmail.com 9925208976</p>	<p>6. Shri K A Vishwanath GM (Project Development) TEQ Green Power XI Pvt. Ltd. 8th Floor, DLF Square, DLF Phase 2, Sector-26, Gurugram 122002 ka.vishwanath@o2power.in</p>
<p>7. Shri Manu Krishnan Namboothiri Head (Strategy, Power sales & Corporate Relationships) DB Power Ltd, 3rd Floor, Naman Corporate Link, Bandra-Kurla Complex, Bandra East, Mumbai 400 051. manu.namboothiri@dbpower.in sales@dbpower.in 7506256244</p>	<p>8. Shri Mohit Jain Manager Renew Urja Shachar Pvt. Ltd. Renew Hub, Commercial Block-1, Zone-6, Golf Course Road, DLF City Phase V, Gurugram, Haryana mohit.jain@renewpower.in +91 9873462717</p>
<p>9. Shri Chaitanya GVLK Vice President Dev & Delivery VEH Saur Urja Pvt. Ltd. 9th Floor, My Home Twitza, Plot No. 30/A, TSIIC Hyderabad Knowledge City, Raidurg, Hyderabad, Telangana – 500081 cgvk@vibrantenergy.in +91 9623470996</p>	<p>10. Shri Ateesh Samant Chief Operating Officer Abenergia Renewables Pvt Ltd. Unit no 203, Trade Centre, Opp MTNL, Bandra Kurla Complex, Bandra East, Mumbai 400051 Maharashtra ateesh.samant@aberenewables.com +91 9820131748</p>
<p>11. Shri Mohit Jain Manager Renew Green Energy Solutions Pvt. Ltd. Renew Hub Commercial Block-1 Zone-6 Golf Course Road DLF City Phase V Gurugram Haryana 122009 mohit.jain@renew.com 9873462717</p>	<p>12. Shri Angshuman Dy General Manager Avaada Energy Pvt. Ltd. C-11, Sector-65, Noida angshuman.rudra@avaada.com +91 7835004673</p>
<p>13. Shri Anish Pasrija General Manager Greenko MP01 IREP Pvt. Ltd. 15th Floor, Hindustan Times House, 18-20 KG Marg Delhi. anish.p@greenkogroup.com +91 9717755423</p>	<p>14. Shri Animesh Manna Dy. General Manager NTPC Renewable Energy Limited, Plot-A-8A, NTPC Ltd, Engineering Office Complex, Sector-24, Noida, Uttar Pradesh 201301 amanna@ntpc.co.in 9650997835</p>

<p>15. Shri Sumit Joge DGM Business Development Sprng Akshaya Urja Pvt. Ltd. Upper Ground Office A -001, Pentgaon-5 Magarpatta City, Hadapsar, Pune.411013 Maharashtra sprngakshayaurja@sprngenergy.com 9545556456</p>	<p>16. Shri K R Ghataliya Sr. Manager (RE Projects) Gujarat Industries Power Company Limited PO. Ranoli, Dist: Vadodara krghataliya@gipcl.com 9724341675</p>
<p>17. Shri Ankush Malik Chief Business Officer Juniper Green Ray Two Pvt. Ltd. Plot No. 18, First Floor, Institutional Area, Sector-32, Gurgaon, Haryana. ankush.malik@junipergreenenergy.com pavan.gupta@junipergreenenergy.com 9910509744</p>	<p>18. Shri Abhijeet R Patil Head Special Projects Tata Power Company Ltd. Generating Station Khopoli, P O Khopoli Power House, District - Raigad, Maharashtra 410 204. abhijeetpatil@tatapower.com vivekmate@tatapower.com 8149095272</p>
<p>19. Shri Prodyut Kr Maji Director Mundra Petrochem Limited Commerce House-4, Prahladnagar, Beside Shell Petrol Pump, Ahmedabad, Gujarat 380015. prodyut.maji@adani.com 8980802771</p>	<p>20. Shri Krishnan A V Vice President Kutch Copper Ltd. 5th Floor, Adani Corporate House, Adani Shantigram, Ahmedabad, Gujarat. krishnan.av@adani.com mohan.natarajan@adani.com 6358980232</p>
<p>21. Shri Bhavik Shah Assistant General Manager Torrent Power Limited Naranpura Zonal Office, Sola Road, Naranpura, Ahmedabad, Gujarat - 380013. bhavikshah@torrentpower.com 9227758405</p>	<p>22. Shri Mehul Rupera Whole-time Director MPSEZ Utilities Limited 3rd Floor, South Wing, Adani Corporate House, Adani Shantigram, Gujarat. mehul.rupera@adani.com 9099002463</p>
<p>23. Vishnu Khandelwal Hindustan Zinc Limited Manager- RE Power Business Yashad Bhawan, Udaipur, Rajasthan Mob. No.: +91-9829030982 Email: vishnu.khandelwal@vedanta.co.in Rajendra.pandwal@vedanta.co.in</p>	

Minutes of 2nd sitting of 21st Consultation Meeting for Evolving Transmission Schemes in Western Region held on 29.08.2023.

The 2nd sitting of 21st Consultation Meeting for Evolving Transmission Schemes in Western Region (CMETS-WR) was held on 29.08.2023. CGM(CTU) welcomed the participants and thereafter, the agenda was taken up for deliberations. The list of participants is attached at **Flag-I**.

A. Processing of New applications received under GNA Regulations, 2022

It was informed that as per the above CERC notification dated 01.04.2023, the provisions regarding fresh applications for Connectivity and GNA and their processing and grant have been made effective from 05.04.2023. Accordingly, a no. of applications for Connectivity and GNA have been received in the Months of Apr/May/June/Jul'23 in conformity with the GNA Regulations, 2022. The applications were discussed in detail and details of deliberations are given in the table below:

I. Application for Connectivity to ISTS under Regulation 4.1, 4.2, 5.6, and 5.7

a) Apr-23

It was informed that following applications for Connectivity to ISTS under Regulation 4.1, 4.2, 5.6, and 5.7 have been received in the month of Apr-23 and the proposal for grant of connectivity as per feedback from developers and based on discussions in the meeting is given below:

Sl. No.	Application ID	Name of the Applicant	Nature of Applicant	Submission Date	Energy Source	Eligibility Criteria	Region	Project Location	Connectivity location (requested)	Quantum (MW)	Connectivity sought from & Actual Start Date*	Dedicated Transmission System for Connectivity	Associated Transmission System for GNA	Common Transmission System Augmentation	BG Details & Remarks (if any)
1.	2200000011	Avaada Inclean Pvt. Ltd. (AIPL)	(i) Generating station(s), including	21-04-2023	Solar	Land Route	WR	Kutch, Gujarat	Lakadiya PS	50	31-12-2024	AIPL – Lakadia 220kV S/c line along with associated bay at Generation end. (Under	• Establishment of 1x500MVA, 400/220kV	NIL	Conn-BG1: 50 Lakhs

Minutes of 2nd sitting of 21st Consultation meeting for Evolving Transmission Schemes in WR held on 29.08.2023

Sl. No.	Application ID	Name of the Applicant	Nature of Applicant	Submission Date	Energy Source	Eligibility Criteria	Region	Project Location	Connectivity location (requested)	Quantum (MW)	Connectivity sought from & Actual Start Date*	Dedicated Transmission System for Connectivity	Associated Transmission System for GNA	Common Transmission System Augmentation	BG Details & Remarks (if any)
			REGS(s), without ESS								Actual: Based on availability of ATS.	the scope of applicant). Implementation of 220kV bay at Lakadia S/s was agreed under ISTS based on request of applicant.	ICT at Lakadia PS along with 220kV switchyard and associated ICT bays		Conn-BG2: As per ATS / terminal bay
2.	2200000021	Serentica Renewables India Pvt. Ltd. (SRIPL)	(i) Generating station(s), including REGS(s), without ESS	29-04-2023	Solar	Land Route	WR	Solapur, Maharashtra	Solapur	300	31-03-2025 Actual: 31.03.2025	SRIPL shall share the dedicated Transmission System for Connectivity of M/s ReNew Green Energy Solutions Pvt. Ltd. (RGESL) with applicant no. 0231400007) as given below: <ul style="list-style-type: none"> RGESL PSS 4 – Solapur (PG) 400kV S/c line (on D/c tower) (with HTLS conductor with minimum capacity of 2100MW at nominal voltage) along with associated bays at both ends (under the scope of applicant) [Solapur PS: Bay no. 433 (400kV AIS- One and Half Breaker Scheme)] <p>Interconnection between RGESL main</p>	NIL	NIL	BG1: 50 Lakhs Conn-BG2: NIL Conn-BG-3: 6 Cr. Applicant stated that the details of exact PSS of ReNew with which they shall interconnect shall be intimated based on discussions with M/s Renew. The same was noted.

Minutes of 2nd sitting of 21st Consultation meeting for Evolving Transmission Schemes in WR held on 29.08.2023

Sl. No.	Application ID	Name of the Applicant	Nature of Applicant	Submission Date	Energy Source	Eligibility Criteria	Region	Project Location	Connectivity location (requested)	Quantum (MW)	Connectivity sought from & Actual Start Date*	Dedicated Transmission System for Connectivity	Associated Transmission System for GNA	Common Transmission System Augmentation	BG Details & Remarks (if any)
												<p>pooling station (PSS 4) and intermediate pooling stations (under the scope of applicant):</p> <ul style="list-style-type: none"> Establishment of 33/400kV Pooling Sub-statin PSS1 Establishment of 33/400kV Pooling Sub-statin PSS2 Establishment of 33/400kV Pooling Sub-statin PSS3 PSS 3 – PSS 1 400kV S/c line (on D/c tower) along with associated bays PSS 2 – PSS 1 400kV S/c line (on D/c towers) along with associated bays PSS 1 – PSS 4 400kV S/c line (on D/c towers) along with associated bays 			
3.	2200000030	Blue Leaf Energy Renewables Pvt. Ltd. (BLERPL)	(i) Generating station(s), including REGS(s), without ESS	25-04-2023	Solar	Land Route	WR	Agar Malwa, Madhya Pradesh	Pachora SEZ PP	235.0	30-06-2025 Actual: 30.06.2025	BLERPL – Pachora PS 220kV S/c line along with associated bay at Generation end. (Under the scope of applicant). 220kV bay at Pachora PS is already under	NIL	<ul style="list-style-type: none"> Establishment of 400/220 kV, 3x500MVA at 	BG1: 50 Lakhs Conn-BG2: 3 Cr. Conn-BG-3: 4.7 Cr.

Minutes of 2nd sitting of 21st Consultation meeting for Evolving Transmission Schemes in WR held on 29.08.2023

Sl. No.	Application ID	Name of the Applicant	Nature of Applicant	Submission Date	Energy Source	Eligibility Criteria	Region	Project Location	Connectivity location (requested)	Quantum (MW)	Connectivity sought from & Actual Start Date*	Dedicated Transmission System for Connectivity	Associated Transmission System for GNA	Common Transmission System Augmentation	BG Details & Remarks (if any)
												implementation under ISTS.		Pachora SEZ PP • Pachora SEZ PP - Bhopal (Sterlite) 400kV D/c line (Quad/Twin HTLS) (with minimum capacity of 2100 MVA/ckt at nominal voltage) (Expected COD of Common Augmentation is 29.11.2023 as per PRM dated 05.07.2023. Forms part of Existing ISTS for the purpose of CERC	Applicant stated that they intend to apply for enhancement of their connectivity quantum by 65MW in month of Sep'23. The same was noted.

Minutes of 2nd sitting of 21st Consultation meeting for Evolving Transmission Schemes in WR held on 29.08.2023

Sl. No.	Application ID	Name of the Applicant	Nature of Applicant	Submission Date	Energy Source	Eligibility Criteria	Region	Project Location	Connectivity location (requested)	Quantum (MW)	Connectivity sought from & Actual Start Date*	Dedicated Transmission System for Connectivity	Associated Transmission System for GNA	Common Transmission System Augmentation	BG Details & Remarks (if any)
															GNA Regulations, 2022)
4.	2200000028	Sprng Vayu Vidyut Pvt. Ltd.	(i) Generating station(s), including REGS(s), without ESS	18-04-2023	Wind	Land Route	WR	Dhar, Madhya Pradesh	Rajgarh	42	31-12-2025 Actual: 31.12.2025	SVVPL shall share Dedicated Transmission System for Connectivity granted to SVVPL for its another WPP of 50.4MW (Stage-II Connectivity Appl. No. 1200003510), as given below: <ul style="list-style-type: none"> SVVPL – Rajgarh 220kV S/c line along with associated line bays at both ends (under the scope of applicant) [Rajgarh S/s: Bay no. 209 (220kV AIS- DMT Scheme)] (SVVPL shall utilize the same dedicated transmission line provided with Stage-II Connectivity of 50.4MW granted to SVVPL (Stage-II Connectivity Appl. No. 1200003510).) 	NIL	NIL	BG1: 50 Lakhs; Conn-BG2: NIL Conn-BG-3: 0.84 Cr. It was informed that with this, total connectivity at 220kV level of Rajgarh S/s shall reach 299.04MW and no further connectivity may be granted at 220kV level. The same was noted.
It was informed that in the land undertaking, end date of project has been mentioned as 31.12.2025. In this respect, applicant informed that the revised undertaking has already been submitted on 9th June 2023 and the same shall again be forwarded by e-mail. The revised land undertaking was re-submitted by M/s SVVPL on 29.08.2023 in which the end date of project has been modified to 01.07.2058.															

Minutes of 2nd sitting of 21st Consultation meeting for Evolving Transmission Schemes in WR held on 29.08.2023

Sl. No.	Application ID	Name of the Applicant	Nature of Applicant	Submission Date	Energy Source	Eligibility Criteria	Region	Project Location	Connectivity location (requested)	Quantum (MW)	Connectivity sought from & Actual Start Date*	Dedicated Transmission System for Connectivity	Associated Transmission System for GNA	Common Transmission System Augmentation	BG Details & Remarks (if any)
5.	2200000022	Sprng Vayu Vidyut Pvt. Ltd.	(i) Generating station(s), including REGS(s), without ESS	17-04-2023	Wind	Land BG Route	WR	Dhar, Madhya Pradesh	Rajgarh	100	31-12-2026 Actual: 31.12.2026 subject to implementation of 3 rd ICT at Rajgarh which shall be taken up after receipt of Conn-BGs given alongside with a minimum implementation schedule of 21 months	SVVPL – Rajgarh (PG) 220kV S/c line along with associated line bay at generation end. (Under the scope of applicant) Implementation of 220kV GIS line bay at Rajgarh 400/220kV (PG) S/s (on extended bus) for RE was agreed under ISTS based on request of applicant. Anticipated completion schedule of extended 220kV bus of Rajgarh S/s: Aug'24 , as per project review meeting held on 05.07.2023.	1x500MVA, 400/220kV ICT (3rd) at Rajgarh S/s (on the sectionalized 220kV bus) along with associated bays at both ends (400kV AIS & 220kV GIS) <i>Shall be taken up for implementation based on acceptance of ATS by applicant(s) and receipt of Conn-BG2.</i> Additional ATS which is Part of Existing ISTS for the purpose of CERC GNA Regulations, 2022: • 220kV bus extension (GIS) of Rajgarh (PG) 400/220 kV S/s	NIL	Conn-BG1: 50 Lakhs Conn-BG2: As per ATS / terminal bay

Minutes of 2nd sitting of 21st Consultation meeting for Evolving Transmission Schemes in WR held on 29.08.2023

Sl. No.	Application ID	Name of the Applicant	Nature of Applicant	Submission Date	Energy Source	Eligibility Criteria	Region	Project Location	Connectivity location (requested)	Quantum (MW)	Connectivity sought from & Actual Start Date*	Dedicated Transmission System for Connectivity	Associated Transmission System for GNA	Common Transmission System Augmentation	BG Details & Remarks (if any)
													along with 220kV Bus Coupler bay for extended bus (under the scope of ISTS) <ul style="list-style-type: none"> • 220kV bus sectionalizer bay (GIS) between existing & extended 220 kV bus of Rajgarh S/s. (under the scope of ISTS) Anticipated completion schedule of above system: Aug'24 , as per project review meeting held on 05.07.2023.		

**Note: The date of commencement of Connectivity under GNA is Interim. The timeline for completion of ATS/ Common Transmission System Augmentation I Terminals bay(s) (if not under implementation) as applicable along with firm date for start of connectivity shall be intimated within 6 months of furnishing of Conn-BG 1 (in case of Augmentation with ATS) and Conn-BG1, Conn-BG2 & Conn-BG3, (as applicable, in case of Augmentation without ATS) in line with Regulation 8.3 b of GNA Regulations.*

After deliberations, it was agreed to grant connectivity to the above applicants as per the proposal given in table above. Further following was informed to the applicants:

- Liability of payment of applicable transmission charges shall as per CERC sharing Regulations, 2020.
- Wherever ATS / Terminal Bay at ISTS end is being implemented by ISTS Licensee as per intimation for grant of connectivity under GNA regulation, in case, COD of the ATS / Terminal bay of Connectivity line is achieved earlier than COD of the Generation project (but not earlier than the start date of Connectivity under GNA), the liability of payment of applicable transmission charges for such mismatch period shall be governed by CERC Sharing Regulations, 2020.

The above was noted and agreed.

b) May-23

It was informed that following applications for Connectivity to ISTS under Regulation 4.1, 4.2, 5.6, and 5.7 have been received in the month of May-23 and the proposal for grant of connectivity as per feedback from developers and based on discussions in the meeting is given below:

Sl. No.	Application ID	Name of the Applicant	Nature of Applicant	Submission Date	Energy Source	Eligibility Criteria	Region	Project Location	Connectivity location (requested)	Quantum (MW)	Connectivity sought from & Actual Start Date	Dedicated Transmission System for Connectivity	Associated Transmission System for GNA	Common Transmission System Augmentation	BG Details & Remarks (if any)
1.	2200000048 (Revised Application)	Gujarat State Electricity Corporation Limited (GSECL)	(x) Renewable Power Park developer	15-05-2023	Solar	Land Route	WR	Khavda, Kutch, Gujarat	Khavda PS-II	1725.0	31-03-2025 <u>Actual: 31.01.2026 (based on expected schedule of Common Augmentation & 400kV bays at KPS2)</u>	For Up to 364MW left in Southern Plot GSECL shall share the connectivity system provided with Stage-II Connectivity to GSECL (Appl. No. 0230700005) which is detailed below: <ul style="list-style-type: none"> • GSECL PS1 (South) – Khavda-II PS 	NIL	Khavda Phase-I: <ul style="list-style-type: none"> • KPS1 – Bhuj 765kV D/c line • KPS1 – KPS2 765kV D/c line Establishment of KPS2 in Khavda RE Park: <ul style="list-style-type: none"> • Establishment of 765/400kV, 4x1500MVA, KPS2(GIS) 	BG1: 50 Lakhs Conn-BG2: 6 Cr. Conn-BG-3: 34.5 Cr.

Minutes of 2nd sitting of 21st Consultation meeting for Evolving Transmission Schemes in WR held on 29.08.2023

Sl. No.	Application ID	Name of the Applicant	Nature of Applicant	Submission Date	Energy Source	Eligibility Criteria	Region	Project Location	Connectivity location (requested)	Quantum (MW)	Connectivity sought from & Actual Start Date	Dedicated Transmission System for Connectivity	Associated Transmission System for GNA	Common Transmission System Augmentation	BG Details & Remarks (if any)
												<p>(Sec-I) 400kV D/c line along with associated bay at Generation end (Under the scope of applicant)#</p> <ul style="list-style-type: none"> Bay at ISTS substation end shall be under the scope of ISTS) @ <p># Above 400kV D/c line shall also cater to 600MW St-II connectivity already granted to GSECL with stage-II application number 1200003331 at KPS-2.</p> <p>@Presently, 1 no. 400kV bay at KPS2 is already under implementation as part of KPS2 S/s establishment which has already been identified to GSECL with stage-II application number 1200003331 at KPS-2 and additional spare bay at KPS2 is envisaged as future bay for diameter</p>		<p>Khavda Phase-II:</p> <ul style="list-style-type: none"> KPS2 – Lakadia 765kV D/c line Establishment of 3x1500 MVA, 765/400 kV Ahmedabad S/s Lakadia – Ahmedabad 765kV D/c line Ahmedabad – Navsari (New) 765kV D/c line LILO of Pirana (PG) – Pirana (T) 400kV D/c line at Ahmedabad S/s with twin HTLS along with reconductoring of Pirana (PG) – Pirana(T) line with twin HTLS conductor and Bay upgradation work at Pirana (PG) & Pirana (T) <p>Above system forms part of Existing ISTS for the purpose</p>	

Minutes of 2nd sitting of 21st Consultation meeting for Evolving Transmission Schemes in WR held on 29.08.2023

Sl. No.	Application ID	Name of the Applicant	Nature of Applicant	Submission Date	Energy Source	Eligibility Criteria	Region	Project Location	Connectivity location (requested)	Quantum (MW)	Connectivity sought from & Actual Start Date	Dedicated Transmission System for Connectivity	Associated Transmission System for GNA	Common Transmission System Augmentation	BG Details & Remarks (if any)
												<p>completion in 400kV Section-1 of KPS2 under transmission scheme</p> <p>"Establishment of Khavda Pooling Station-2 (KPS2) in Khavda RE Park".</p> <p>For balance 1361MW in Northern Plot:</p> <ul style="list-style-type: none"> GSECL PS2 (North) – Khavda-II PS (Sec-II) 400kV S/c line along with associated bay at Generation end (Under the scope of applicant) Bay at ISTS substation end shall be under the scope of ISTS)@ <p>@Addl. Bays on Sec-II are being implemented with Khavda Ph-IV Part E2 scheme (approved in 14th NCT with schedule of 21 months)</p>		<p>of CERC GNA Regulations, 2022</p> <p>Khavda Phase-III:</p> <ul style="list-style-type: none"> Establishment of 765 kV Halvad switching station KPS2- Halvad 765 kV D/c line LILO of Lakadia – Ahmedabad 765 kV D/c line at Halvad Halvad – Vataman 765 kV D/c line Establishment of 765 kV switching station near Vataman LILO of Lakadia – Vadodara 765 kV D/c line at Vataman 765 kV switching station Vataman switching station – Navsari(New) 765 kV D/c line 	

Minutes of 2nd sitting of 21st Consultation meeting for Evolving Transmission Schemes in WR held on 29.08.2023

Sl. No.	Application ID	Name of the Applicant	Nature of Applicant	Submission Date	Energy Source	Eligibility Criteria	Region	Project Location	Connectivity location (requested)	Quantum (MW)	Connectivity sought from & Actual Start Date	Dedicated Transmission System for Connectivity	Associated Transmission System for GNA	Common Transmission System Augmentation	BG Details & Remarks (if any)
												<p>Note: Interconnection between GSECL PS1 & PS2 shall be kept normally open and can be closed under contingency conditions only. Applicant noted and agreed the same.</p>		<p>Khavda Phase-IV</p> <ul style="list-style-type: none"> • Creation of 765kV bus section-II at KPS3 (GIS) along with 765kV Bus Sectionalizer • Creation of 400kV bus section-II at KPS3 (GIS) along with 400kV Bus Sectionalizer • KPS3 (GIS) – Lakadia (AIS) 765 kV D/C line • ±300MVar STATCOM with 1x125 MVar MSC, 2x125 MVar MSR at KPS3 400kV Bus section-2 • KPS1 (GIS)– Bhuj PS 765 kV 2nd D/C line • Establishment of 2x1500MVA, 765/400kV & 2x500MVA, 400/220kV GIS S/s at a suitable location South of Olpad (between Olpad and Ichhapore) 	

Minutes of 2nd sitting of 21st Consultation meeting for Evolving Transmission Schemes in WR held on 29.08.2023

Sl. No.	Application ID	Name of the Applicant	Nature of Applicant	Submission Date	Energy Source	Eligibility Criteria	Region	Project Location	Connectivity location (requested)	Quantum (MW)	Connectivity sought from & Actual Start Date	Dedicated Transmission System for Connectivity	Associated Transmission System for GNA	Common Transmission System Augmentation	BG Details & Remarks (if any)
														<ul style="list-style-type: none"> • Vadodara(GIS) –South Olpad(GIS) 765 kV D/C line • LILO of Gandhar – Hazira 400kV D/c line at South Olpad (GIS) using twin HTLS conductor with minimum capacity of 1700MVA per ckt at nominal voltage • Ahmedabad – South Olpad(GIS) 765kV D/c line • Establishment of 4X1500 MVA 765/400 kV & 2x500MVA 400/220kV Boisar-II (GIS) • South Olpad(GIS) – Boisar-II(GIS) 765kV D/c line • LILO of Navsari(New) – Padghe(PG) 765kV D/c line at Boisar-II • Boisar-II (Sec-II) – Velgaon(MH) 400kV D/c (Quad ACSR/AAAC/A 	

Minutes of 2nd sitting of 21st Consultation meeting for Evolving Transmission Schemes in WR held on 29.08.2023

Sl. No.	Application ID	Name of the Applicant	Nature of Applicant	Submission Date	Energy Source	Eligibility Criteria	Region	Project Location	Connectivity location (requested)	Quantum (MW)	Connectivity sought from & Actual Start Date	Dedicated Transmission System for Connectivity	Associated Transmission System for GNA	Common Transmission System Augmentation	BG Details & Remarks (if any)
														L59 moose equivalent) line • LILO of Babhaleswar – Padghe(M) 400kV D/c line at Boisar-II (Sec-I) using twin HTLS conductor with minimum capacity of 1700MVA per ckt at nominal voltage • ±200MVar STATCOM with 2x125 MVar MSC, 1x125 MVar MSR at 400 kV bus section-I of Boisar-II and ±200MVar STATCOM with 2x125 MVar MSC, 1x125 MVar MSR at 400 kV bus section-II of Boisar-II • ± 300 MVar STATCOM with 3x125 MVar MSC, 1x125 MVar MSR at 400 kV level of Navsari(New)(PG) S/s with 1 No. of 400 kV bay (GIS)	

Minutes of 2nd sitting of 21st Consultation meeting for Evolving Transmission Schemes in WR held on 29.08.2023

Sl. No.	Application ID	Name of the Applicant	Nature of Applicant	Submission Date	Energy Source	Eligibility Criteria	Region	Project Location	Connectivity location (requested)	Quantum (MW)	Connectivity sought from & Actual Start Date	Dedicated Transmission System for Connectivity	Associated Transmission System for GNA	Common Transmission System Augmentation	BG Details & Remarks (if any)
														<ul style="list-style-type: none"> Establishment of 2X1500 MVA 765/400 kV & 3x500MVA 400/220kV Pune-III (GIS) Boisar-II – Pune-III 765kV D/c line LILO of Narendra (New) – Pune(GIS) 765kV D/c line at Pune-III LILO of Hinjewadi-Koyana 400kV S/c line at Pune-III(GIS) S/s Augmentation of transformation capacity at Padghe (GIS) 765/400 kV substation by 1x1500 MVA ICT (4th) along with associated bays <p>KPS2 Augmentation Scheme (Khavda Ph-IV Part E-2):</p> <ul style="list-style-type: none"> Augmentation of transformation capacity at KPS2 (GIS) by 	

Minutes of 2nd sitting of 21st Consultation meeting for Evolving Transmission Schemes in WR held on 29.08.2023

Sl. No.	Application ID	Name of the Applicant	Nature of Applicant	Submission Date	Energy Source	Eligibility Criteria	Region	Project Location	Connectivity location (requested)	Quantum (MW)	Connectivity sought from & Actual Start Date	Dedicated Transmission System for Connectivity	Associated Transmission System for GNA	Common Transmission System Augmentation	BG Details & Remarks (if any)
														2x1500 MVA, 765/400 kV ICT on Bus section-I (5th & 6th) & 2x1500 MVA, 765/400 kV ICT on Bus section-II (7th & 8th) [Anticipated completion schedule of the above transmission system: Progressively by 31.01.2026 (expected)]	
2.	2200000035 (Revised Enhancement Application)	Teq Green Power XI Private Limited	(ii) Generating station(s), incl. REGS(s), without ESS through a lead generator	10-05-2023	Wind	Land BG Route	WR	Osman abad and Beed, Maharashtra	Kallam PS	29.7	30-09-2024 Actual: 30.06.2025	TGPXIPL shall share the connectivity system provided with Stage-II Connectivity to TGPXIPL (St-II Connectivity Appl. No. 1200003901): <ul style="list-style-type: none"> TGPXIPL – Kallam PS 220kV S/c line (on D/c tower) along with associated bay at Generation end (under the scope of applicant) Bay at ISTS substation end is already under implementation as a part of ISTS. [Bay no. 205 (220kV AIS-DMT Scheme)] (anticipated) 	NIL	<ul style="list-style-type: none"> Augmentation of transformation capacity at Kallam PS by 2x500 MVA, 400/220 kV ICTs (3rd & 4th) [Anticipated completion schedule of the above transmission system: 14.05.2024 (as per project review meeting held on 05.07.2023)] 	BG1: 50 Lakhs; Conn-BG2: NIL Conn-BG-3: 0.594 Cr. Applicant informed that connectivity has been applied on behalf of M/s O2 RENEWABLE ENERGY III PRIVATE LIMITED & the Lead Generatio

Minutes of 2nd sitting of 21st Consultation meeting for Evolving Transmission Schemes in WR held on 29.08.2023

Sl. No.	Application ID	Name of the Applicant	Nature of Applicant	Submission Date	Energy Source	Eligibility Criteria	Region	Project Location	Connectivity location (requested)	Quantum (MW)	Connectivity sought from & Actual Start Date	Dedicated Transmission System for Connectivity	Associated Transmission System for GNA	Common Transmission System Augmentation	BG Details & Remarks (if any)
												completion schedule: 31.10.2023, as per project review meeting held on 05.07.2023)		[Forms part of Existing ISTS for the purpose of CERC GNA Regulations, 2022] <ul style="list-style-type: none"> LILO of both circuits of Parli(M) – Karjat(M)/Lonik andII(M) 400kV D/c line (twin moose) at Kallam PS (approved in 14th NCT meeting held on 09.06.2023 with implementation timeline of 18 months from SPV transfer, tentative completion schedule: 30.06.2025*) 	n Agreement has also been submitted. The above was noted.
3.	2200000038 (Original Enhancement Application)	D B Power Limited (Present application is for enhancement of connectivity from 1089 MW to 1200 MW of D B	(i) Generating station(s), including REGS(s), without ESS	09-05-2023	Thermal	NA	WR	Janjgir-Champa, Chhattisgarh	Raigarh Pooling Station (Near Kotra)	111.0	05-05-2023 <u>Actual: Based on completion of formalities as per CERC GNA Regulations, 2022</u>	The enhancement of connectivity shall utilize the dedicated transmission system for connectivity of DB Power as given below (existing): <ul style="list-style-type: none"> DB Power TPS – Raigarh Pooling station (near Kotra) 	NIL	NIL	BG1: 50 Lakhs; Conn-BG2: NIL Conn-BG-3: 2.22 Cr.

Minutes of 2nd sitting of 21st Consultation meeting for Evolving Transmission Schemes in WR held on 29.08.2023

Sl. No.	Application ID	Name of the Applicant	Nature of Applicant	Submission Date	Energy Source	Eligibility Criteria	Region	Project Location	Connectivity location (requested)	Quantum (MW)	Connectivity sought from & Actual Start Date	Dedicated Transmission System for Connectivity	Associated Transmission System for GNA	Common Transmission System Augmentation	BG Details & Remarks (if any)
		Power Limited)										400kV D/c (Quad) line			
4.	2200000039 (Revised Application)	Sprng Akshaya Urja Private Limited (SAUPL)	(i) Generating station(s), including REGS(s), without ESS	04-05-2023	Wind	LOA (REMCL LOA of 100MW (RTC) quantum (wind component: 188MW)	WR	Dhar, Madhya Pradesh	Rajgarh	100.0	30-06-2025 Actual: 30.06.2025 subject to implementation of 3rd ICT at Rajgarh which shall be taken up after receipt of Conn-BGs given alongside with a minimum implementation schedule of 21 months	SAUPL shall share the connectivity system of SVVPL (Appl. No. 2200000022) which is detailed below: <ul style="list-style-type: none"> SVVPL – Rajgarh (PG) 220kV S/c line along with associated line bay at generation end. (Under the scope of applicant) Implementation of 220kV GIS line bay at Rajgarh 400/220kV (PG) S/s (on extended bus) for RE is agreed under ISTS based on request of applicant. 	1x500MVA, 400/220kV ICT (3rd) at Rajgarh S/s (on the sectionalized 220kV bus) along with associated bays at both ends (400kV AIS & 220kV GIS) <i>Shall be taken up for implementation based on acceptance of ATS by applicant(s) and receipt of Conn-BG2.</i> Additional ATS which is Part of Existing ISTS for the purpose of CERC GNA Regulations, 2022: <ul style="list-style-type: none"> 220kV bus extension (GIS) of Rajgarh (PG) 400/220 	NIL	Conn-BG1: 50 Lakhs Conn-BG2: As per ATS / terminal bay

Minutes of 2nd sitting of 21st Consultation meeting for Evolving Transmission Schemes in WR held on 29.08.2023

Sl. No.	Application ID	Name of the Applicant	Nature of Applicant	Submission Date	Energy Source	Eligibility Criteria	Region	Project Location	Connectivity location (requested)	Quantum (MW)	Connectivity sought from & Actual Start Date	Dedicated Transmission System for Connectivity	Associated Transmission System for GNA	Common Transmission System Augmentation	BG Details & Remarks (if any)
													kV S/s along with 220kV Bus Coupler bay for extended bus (under the scope of ISTS) <ul style="list-style-type: none"> 220kV bus sectionalizer bay (GIS) between existing & extended 220 kV bus of Rajgarh S/s. (under the scope of ISTS) Anticipated completion schedule of ISTS system: Aug'24 , as per project review meeting held on 05.07.2023.		
5.	2200000085 (Original Application)	VEH Saur Urja Private Limited (VSUPL)	(i) Generating station(s), including REGS(s), without ESS	30-05-2023	Wind	Land Route	WR	Agar Malwa, Madhya Pradesh	Pachora PS	163.2	30-06-2025 Actual: 30.06.2025	VSUPL – Pachora PS 220kV S/c line along with associated bay at Generation end. (Under the scope of applicant). 220kV bay at Pachora PS is already under	NIL	<ul style="list-style-type: none"> Establishment of 400/220 kV, 3x500MVA at Pachora SEZ PP Pachora SEZ PP - Bhopal (Sterlite) 400kV D/c line 	BG1: 50 Lakhs Conn-BG2: 3 Cr. Conn-BG-3: 3.264 Cr.

Minutes of 2nd sitting of 21st Consultation meeting for Evolving Transmission Schemes in WR held on 29.08.2023

Sl. No.	Application ID	Name of the Applicant	Nature of Applicant	Submission Date	Energy Source	Eligibility Criteria	Region	Project Location	Connectivity location (requested)	Quantum (MW)	Connectivity sought from & Actual Start Date	Dedicated Transmission System for Connectivity	Associated Transmission System for GNA	Common Transmission System Augmentation	BG Details & Remarks (if any)
												implementation under ISTS.		(Quad/Twin HTLS) (with minimum capacity of 2100 MVA/ckt at nominal voltage) (expected COD of Common Augmentation is 29.11.2023 as per PRM dated 05.07.2023) <i>Forms part of Existing ISTS for the purpose of CERC GNA Regulations, 2022</i>	Applicant stated that they intend to apply for enhancement of their connectivity quantum by 150MW in Sep-23.
6.	220000070 (Revised Application)	Renew Urja Shachar Private Limited (RUSPL)	(i) Generating station(s), including REGS(s), without ESS	30-05-2023	Wind	Land BG Route	WR	Ujjain, Madhya Pradesh	Indore S/s	300.0	30-06-2025 Actual: 30.06.2025	RUSPL – Indore (Sec-A: With Indore & Khandwa lines) 400kV S/c line (on D/c tower) along with associated bay at Generation end. (Under the scope of applicant). Implementation of 400kV Bay at Indore S/s was agreed under ISTS)	NIL	NIL	BG1: 50 Lakhs Conn-BG2: 6 Cr. Conn-BG-3: 6 Cr.
7.	220000071 (Revised Enhancement Application)	Renew Green Energy Solutions Private Limited (RGESL)	(i) Generating station(s), including REGS(s), without ESS	30-05-2023	Solar	Land Route	WR	Solapur, Maharashtra	Solapur	73.0	31-03-2025 Actual: 31.03.2025	RGESL shall share the dedicated Transmission System for Connectivity of M/s ReNew Green Energy Solutions Pvt. Ltd. (RGESL) with applicant no.	NIL	NIL	BG1: 50 Lakhs; Conn-BG2: NIL Conn-BG-3: 1.46 Cr.

Minutes of 2nd sitting of 21st Consultation meeting for Evolving Transmission Schemes in WR held on 29.08.2023

Sl. No.	Application ID	Name of the Applicant	Nature of Applicant	Submission Date	Energy Source	Eligibility Criteria	Region	Project Location	Connectivity location (requested)	Quantum (MW)	Connectivity sought from & Actual Start Date	Dedicated Transmission System for Connectivity	Associated Transmission System for GNA	Common Transmission System Augmentation	BG Details & Remarks (if any)
												0231400007) as given below: <ul style="list-style-type: none"> RGESL PSS 4 – Solapur (PG) 400kV S/c line (on D/c tower) (with HTLS conductor with minimum capacity of 2100MW at nominal voltage) along with associated by at both ends (under the scope of applicant) [Solapur PS: Bay no. 433 (400kV AIS- One and Half Breaker Scheme)] <p>Interconnection between RGESL main pooling station (PSS 4) and intermediate pooling stations (under the scope of applicant):</p> <ul style="list-style-type: none"> Establishment of 33/400kV Pooling Sub-station PSS1 Establishment of 33/400kV 			

Minutes of 2nd sitting of 21st Consultation meeting for Evolving Transmission Schemes in WR held on 29.08.2023

Sl. No.	Application ID	Name of the Applicant	Nature of Applicant	Submission Date	Energy Source	Eligibility Criteria	Region	Project Location	Connectivity location (requested)	Quantum (MW)	Connectivity sought from & Actual Start Date	Dedicated Transmission System for Connectivity	Associated Transmission System for GNA	Common Transmission System Augmentation	BG Details & Remarks (if any)
												Pooling Sub-station PSS2 • Establishment of 33/400kV Pooling Sub-station PSS3 • PSS 3 – PSS 1 400kV S/c line (on D/c tower) along with associated bays • PSS 2 – PSS 1 400kV S/c line (on D/c towers) along with associated bays • PSS 1 – PSS 4 400kV S/c line (on D/c towers) along with associated bays			
8.	2200000026 (Revised Enhancement Application)	Renew Green Energy Solutions Private Limited	(i) Generating station(s), including REGS(s), without ESS	02-05-2023	Solar	Land Route	WR	Solapur, Maharashtra	Solapur	51.0	31-03-2025 Actual: 31.03.2025	RGESL shall share the dedicated Transmission System for Connectivity of M/s ReNew Green Energy Solutions Pvt. Ltd. (RGESL) with applicant no. 0231400007) as given below: • RGESL PSS 4 – Solapur (PG) 400kV S/c line (on D/c tower) (with HTLS conductor with	NIL	NIL	BG1: 50 Lakhs; Conn-BG2: NIL Conn-BG-3: 1.02 Cr.

Minutes of 2nd sitting of 21st Consultation meeting for Evolving Transmission Schemes in WR held on 29.08.2023

Sl. No.	Application ID	Name of the Applicant	Nature of Applicant	Submission Date	Energy Source	Eligibility Criteria	Region	Project Location	Connectivity location (requested)	Quantum (MW)	Connectivity sought from & Actual Start Date	Dedicated Transmission System for Connectivity	Associated Transmission System for GNA	Common Transmission System Augmentation	BG Details & Remarks (if any)
												minimum capacity of 2100MW at nominal voltage) along with associated bays at both ends (under the scope of applicant) [Solapur PS: Bay no. 433 (400kV AIS- One and Half Breaker Scheme)] Interconnection between RGS main pooling station (PSS 4) and intermediate pooling stations (under the scope of applicant): <ul style="list-style-type: none"> • Establishment of 33/400kV Pooling Sub-station PSS1 • Establishment of 33/400kV Pooling Sub-station PSS2 • Establishment of 33/400kV Pooling Sub-station PSS3 • PSS 3 – PSS 1 400kV S/c line 			

Sl. No.	Application ID	Name of the Applicant	Nature of Applicant	Submission Date	Energy Source	Eligibility Criteria	Region	Project Location	Connectivity location (requested)	Quantum (MW)	Connectivity sought from & Actual Start Date	Dedicated Transmission System for Connectivity	Associated Transmission System for GNA	Common Transmission System Augmentation	BG Details & Remarks (if any)
												(on D/c tower) along with associated bays • PSS 2 – PSS 1 400kV S/c line (on D/c towers) along with associated bays • PSS 1 – PSS 4 400kV S/c line (on D/c towers) along with associated bays			

**The date of commencement of Connectivity under GNA is Interim. The timeline for completion of ATS/ Common Transmission System Augmentation /Terminals bay(s) (if not under implementation) as applicable along with firm date for start of connectivity shall be intimated within 6 months of furnishing of Conn-BG 1 (in case of Augmentation with ATS) and Conn-BG1, Conn-BG2 & Conn-BG3, (as applicable, in case of Augmentation without ATS) in line with Regulation 8.3 b of GNA Regulations.*

After deliberations, it was agreed to grant connectivity to the above applicants as per the proposal given in table above. Further following was informed to the applicants:

- Liability of payment of applicable transmission charges shall as per CERC sharing Regulations, 2020.
- Wherever ATS / Terminal Bay at ISTS end is being implemented by ISTS Licensee as per intimation for grant of connectivity under GNA regulation, in case, COD of the ATS / Terminal bay of Connectivity line is achieved earlier than COD of the Generation project (but not earlier than the start date of Connectivity under GNA), the liability of payment of applicable transmission charges for such mismatch period shall be governed by CERC Sharing Regulations, 2020.

The above was noted and agreed.

c) Jun-23

It was informed that following applications for Connectivity to ISTS under Regulation 4.1, 4.2, 5.6, and 5.7 have been received in the month of Jun-23 and the proposal for grant of connectivity as per feedback from developers and based on discussions in the meeting is given below:

Sl. No.	Application ID	Name of the Applicant	Nature of Applicant	Submission Date	Energy Source	Eligibility Criteria	Region	Project Location	Connectivity location (requested)	Quantum (MW)	Connectivity sought from & Actual Start Date*	Dedicated Transmission System for Connectivity	Associated Transmission System for GNA	Common Transmission System Augmentation	BG Details
1.	2200000086 (Revised Application)	Abenergia Renewables Private Limited (ARPL)	(vi) Captive generating plant	09-06-2023	Hybrid (RHGS)	Land BG Route	WR	Agar, Madhya Pradesh	Pachora PS	100.0	30-09-2024 Actual: 31.10.2025	<ul style="list-style-type: none"> ARPL – Pachora PS 220kV S/c line along with associated bay at Generation end. (Under the scope of applicant). 220kV bay at Pachora PS is already under tendering under ISTS as part of Rajgarh Ph-II (1GW) scheme. 	NIL	<ul style="list-style-type: none"> Establishment of 400/220 kV, 3x500MVA at Pachora SEZ PP Pachora SEZ PP - Bhopal (Sterlite) 400kV D/c line (Quad/Twin HTLS) (with minimum capacity of 2100 MVA/ckt at nominal voltage) (expected COD of Common Augmentation is 29.11.2023 as per PRM dated 05.07.2023) <i>Forms part of Existing ISTS for the purpose of CERC GNA Regulations, 2022</i> 400/220 kV, 3x500 MVA ICT augmentation (4th 5th and 6th) at Pachora PS Pachora PS – Ujjain (MPPTCL) 400 kV D/c line (Quad ACSR/AAAC/AL59 Moose equivalent) (Scheme is currently under tendering with expected COD by Oct-25.) 	BG1: 50 Lakhs Conn-BG2: 3 Cr. Conn-BG-3: 2 Cr. Applicant stated that they intend to apply for enhancement of their connectivity quantum by 80MW in Sep-23.
Applicant enquired if their capacity may be accommodated in Rajgarh Phase-I (1.5GW) scheme, which is anticipated earlier. It was explained that applications for 1398MW have already been linked with Rajgarh Ph-I (1.5GW) scheme and considering a power factor of 0.95, 1425MW power can only be injected at Pachora PS considering the Ph-I ICTs at Pachora PS (3x500MVA, 400/220kV). Nevertheless, the applicant may evacuate power under short term (T-GNA) based on margins available on 3x500MVA, 400/220kV ICTs being implemented at Pachora PS under Phase-I. However, for grant of connectivity under GNA to M/s Abenergia, the Rajgarh SEZ Ph-II scheme (including the balance 400/220kV ICTs at Pachora PS) shall be required. The applicant noted the same.															
2.	2200000082 (Revised Application)	Avaada Energy Private	(i) Generating station(s), including	05-06-2023	Solar	Land BG Route	WR	Agar-Malwa,	Pachora PS	50.0	31-03-2025	Considering the small quantum of connectivity,	NIL	<ul style="list-style-type: none"> Establishment of 400/220 kV, 3x500MVA at Pachora SEZ PP 	BG1: 50 Lakhs

Minutes of 2nd sitting of 21st Consultation meeting for Evolving Transmission Schemes in WR held on 29.08.2023

Sl. No.	Application ID	Name of the Applicant	Nature of Applicant	Submission Date	Energy Source	Eligibility Criteria	Region	Project Location	Connectivity location (requested)	Quantum (MW)	Connectivity sought from & Actual Start Date*	Dedicated Transmission System for Connectivity	Associated Transmission System for GNA	Common Transmission System Augmentation	BG Details
		Limited (AEPL)	REGS(s), without ESS					Madhya Pradesh			Actual: 31.10.2025	<p>sharing of bay with another applicant such as Blue leaf (235MW). Veh Saur Urja (163.2MW) or Abenergia (100MW) was proposed. However, the applicant requested for a separate bay considering that they shall be applying for enhancement of their connectivity quantum by 250MW in Sep-23. In view of the above, dedicated connectivity system was agreed as under:</p> <ul style="list-style-type: none"> • ARPL – Pachora PS 220kV S/c line along with associated bay at Generation end. (Under the scope of applicant). • 220kV bay at Pachora PS is already under tendering under ISTS as part of Rajgarh Ph-II (1GW) scheme 		<ul style="list-style-type: none"> • Pachora SEZ PP - Bhopal (Sterlite) 400kV D/c line (Quad/Twin HTLS) (with minimum capacity of 2100 MVA/ckt at nominal voltage) (expected COD of Common Augmentation is 29.11.2023 as per PRM dated 05.07.2023) <i>Forms part of Existing ISTS for the purpose of CERC GNA Regulations, 2022</i> • 400/220 kV, 3x500 MVA ICT augmentation (4th 5th and 6th) at Pachora PS • Pachora PS – Ujjain (MPPTCL) 400 kV D/c line (Quad ACSR/AAAC/AL59 Moose equivalent) (Scheme is currently under tendering with expected COD by Oct-25.) 	<p>Conn-BG2: 3 Cr. Conn-BG-3: 1 Cr. Applicant stated that they intend to apply for enhancement of their connectivity quantum by 250MW in Sep-23.</p>

Minutes of 2nd sitting of 21st Consultation meeting for Evolving Transmission Schemes in WR held on 29.08.2023

Sl. No.	Application ID	Name of the Applicant	Nature of Applicant	Submission Date	Energy Source	Eligibility Criteria	Region	Project Location	Connectivity location (requested)	Quantum (MW)	Connectivity sought from & Actual Start Date*	Dedicated Transmission System for Connectivity	Associated Transmission System for GNA	Common Transmission System Augmentation	BG Details
3.	2200000075 (Revised Application)	Avaada Energy Private Limited	(i) Generating station(s), including REGS(s), without ESS	05-06-2023	Wind	Land BG Route	WR	Beed, Maharashtra	Kallam PS	50.0	31-12-2024 Actual: 30.06.2025	As no capacity is left at 220kV level of Kallam PS, connectivity was proposed through sharing of Dedicated Transmission System for Connectivity granted to TSPPL for its WPP of 66MW (St-II Connectivity appl. no. 1670224223993) as per details below: <ul style="list-style-type: none"> TSPPL – Kallam PS 400kV S/c line along with associated bay at generation end (under the scope of applicant) 1 no. 400kV line bay at ISTS substation end (under the scope of ISTS). (anticipated completion schedule: 30.12.2024, as per project review meeting held on 05.07.2023) 	NIL	LILO of both circuits of Parli(M) – Karjat(M)/Lonikandli(M) 400kV D/c line (twin moose) at Kallam PS (approved in 14th NCT meeting held on 09.06.2023 with implementation timeline of 18 months from SPV transfer, tentative completion schedule: 30.06.2025)	BG1: 50 Lakhs Conn-BG2: NIL Conn-BG-3: 1 Cr.

Minutes of 2nd sitting of 21st Consultation meeting for Evolving Transmission Schemes in WR held on 29.08.2023

Sl. No.	Application ID	Name of the Applicant	Nature of Applicant	Submission Date	Energy Source	Eligibility Criteria	Region	Project Location	Connectivity location (requested)	Quantum (MW)	Connectivity sought from & Actual Start Date*	Dedicated Transmission System for Connectivity	Associated Transmission System for GNA	Common Transmission System Augmentation	BG Details
												<p><u>Applicant stated that they shall confirm for Connectivity after taking up the matter with TSPPL and shall revert back in 1 week time. M/s AEPL vide e-mail dated 13.09.2023 informed that they have taken up the matter with M/s TSPPL and requested to discuss the application in the next meeting. Accordingly, the application shall be deliberated again in the next meeting.</u></p>			
4.	220000089 (Revised Application)	Greenko MP01 IREP Private Limited (Greenko MP01-1)	(vii) Standalone ESS	09-06-2023	Standalone ESS	Not applicable being Pumped Storage	WR	Rampura, Neemuch, Madhya Pradesh	Mandsaur PS	504.0	14-11-2025 Actual: 31.12.2025	<ul style="list-style-type: none"> Greenko MP01-1 – Mandsaur PS 400kV D/c (Quad ACSR/AAAC/AL59 moose equivalent) line along with associated bay at Greenko MP01-1 end. (Under the scope of applicant). Implementation of 2 nos. 400kV bays at Mandsaur PS 	NIL	<ul style="list-style-type: none"> Establishment of 3x1500 MVA, 765/400 kV Mandsaur Pooling Station (along with associated bays) Mandsaur PS – Indore(PG) 765 kV D/c Line Establishment of 765/400 kV (2x1500 MVA), 400/22 kV (2x500 MVA) & 220/132 kV (3x200 MVA) Kurawar S/s Mandsaur – Kurawar 765 kV D/c line along with LILO of Indore – Bhopal 765 kV S/c line at Kurawar Kurawar – Ashtha 400 kV D/c (Quad 	Conn-BG1: 50 Lakhs Conn-BG2: 12 Cr. Conn-BG3: 10.08 Cr.

Minutes of 2nd sitting of 21st Consultation meeting for Evolving Transmission Schemes in WR held on 29.08.2023

Sl. No.	Application ID	Name of the Applicant	Nature of Applicant	Submission Date	Energy Source	Eligibility Criteria	Region	Project Location	Connectivity location (requested)	Quantum (MW)	Connectivity sought from & Actual Start Date*	Dedicated Transmission System for Connectivity	Associated Transmission System for GNA	Common Transmission System Augmentation	BG Details
												end was deliberated and M/s Greenko stated that they shall confirm the same within 2 days. Subsequently, M/s Greenko vide e-mail dated 31.08.2023 confirmed development of 2 nos. 400kV bays at Mandsaur PS under ISTS. Hence, the bays shall now be implemented under ISTS.	<p>ACSR/AAAC/AL59 moose equivalent) line</p> <ul style="list-style-type: none"> LILO of one circuit of Indore – Itarsi 400 kV D/ c line at Astha Shujalpur – Kurawar 400 kV D/c (Quad ACSR/AAAC/AL59 moose equivalent) line <p>In addition to above system, the following system shall also be required:</p> <ul style="list-style-type: none"> Augmentation of transformation capacity at Mandsaur PS by 1x1500 MVA, 765/400 kV ICT (4th) along with associated bays 		
5.	220000090 (Revised Application)	Greenko MP01 IREP Private Limited (Greenko MP01-2)	(vii) Standalone ESS	09-06-2023	Standalone ESS	Not applicable being Pumped Storage	WR	Rampur a, Neemuch, Madhya Pradesh	Mandsaur PS	504.0	15-01-2026 Actual: 15.01.2026	Connectivity is proposed through sharing of Dedicated Transmission System for Connectivity granted to Greenko MP01-1 for its ESS of 504MW (Connectivity under GNA appl. no. 2200000089) as per details given above.		Conn-BG1: 50 Lakhs Conn-BG2: NIL Conn-BG3: 10.08 Cr.	
6.	220000091 (Revised Application)	Greenko MP01 IREP	(vii) Standalone ESS	09-06-2023	Standalone ESS	Not applicable	WR	Rampur a, Neemuch	Mandsaur PS	504.0	16-03-2026	Connectivity is proposed through sharing of		Conn-BG1: 50 Lakhs	

Minutes of 2nd sitting of 21st Consultation meeting for Evolving Transmission Schemes in WR held on 29.08.2023

Sl. No.	Application ID	Name of the Applicant	Nature of Applicant	Submission Date	Energy Source	Eligibility Criteria	Region	Project Location	Connectivity location (requested)	Quantum (MW)	Connectivity sought from & Actual Start Date*	Dedicated Transmission System for Connectivity	Associated Transmission System for GNA	Common Transmission System Augmentation	BG Details
		Private Limited (Greenko MP01-3)				being Pumped Storage		h, Madhya Pradesh			Actual: 16.03.2026	Dedicated Transmission System for Connectivity granted to Greenko MP01-1 for its ESS of 504MW (Connectivity under GNA appl. no. 2200000089) as per details given above.			Conn-BG2: NIL Conn-BG3: 10.08 Cr.
<p>It was informed that:</p> <p>1. For above applications by Greenko, Applicant has requested to grant connectivity at Mandsaur PS through 400 KV Quad D/C transmission line (with suitable conductor) considering the entire capacity of the said PSP project as 1920 MW (in turbine mode) and 2016 MW (in pumping mode). Applicant has further stated that they shall be applying for balance 504 MW connectivity shortly.</p> <p>2. The Mandsaur PS is being set-up with 3x1500MVA, 765/400kV ICTs to enable evacuation of power from 2GW Wind Potential (W/o BESS) identified under 181.5GW REZ potential. The S/s has been approved in the 14th NCT meeting held on 09.06.2023 & Gazette is to be issued with implementation time-frame of 24 months from SPV Transfer. Expected SCOD may be considered as Dec-25 assuming SPV transfer in Dec-23. The present application shall result in cumulative injection of 3512MW (incl. 2000MW WEZ) at 400kV level of Mandsaur PS and hence, an additional 1x1500MVA, 765/400kV ICT (4th) is required. In this respect, it may be noted that the 4th 765/400kV ICT at Mandsaur PS is required for reliability in case of contingency of one 765/400kV ICT. Further, since the PSPs are expected to tie up power from RE sources (as also confirmed by Greenko during the meeting), the RE power stored during high RE periods shall be dispatched in conjunction with the 2GW WEZ at Mandsaur PS. Thus, the 4th ICT would be catering to WEZ potential and would also facilitate evacuation of RE power stored in PSP in a reliable manner. Hence, the 1x1500 MVA, 765/400 kV ICT (4th) at Mandsaur PS shall serve both RE projects as well as the subject PSPs (Energy storage). In view of above, the 4th 765/400kV ICT is proposed under Common Transmission system augmentation.</p> <p>Representative of Greenko stated that the common transmission system for connectivity part of the transmission system required for their project may be prioritized and developed in Phases to enable their project connectivity with the ISTS grid.</p> <p>It was clarified that the entire system (except 4th 765/400kV ICT at Mandsaur PS) has recently been agreed in the 14th NCT meeting held on 09.06.2023 and shall be awarded with minimum implementation schedule of 24 months. Hence, there is no question of phasing the transmission system. Even the 4th 765/400kV ICT shall be taken up for approval without any delay and M/s Greenko was requested to submit requisite BGs at the earliest to facilitate the same. Applicant noted the same.</p>															
7.	2200000083 (Revised Application)	Avaada Energy Private Limited (AEPL)	(i) Generating station(s), including REGS(s), without ESS	06-06-2023	Wind	Land BG Route	WR	Sangao n, Beed, Mahara shtra	Parli (New) S/s	50.0	31-12-2024 Actual: 31.12.2025 (as per start date of connectivity requested by RPSPL)	Considering the small quantum of power to be injected by AEPL, Connectivity was proposed through sharing of Dedicated Transmission System for Connectivity granted to RPSPL	NIL	NIL	BG1: 50 Lakhs Conn-BG2: NIL Conn-BG-3: 1 Cr.

Minutes of 2nd sitting of 21st Consultation meeting for Evolving Transmission Schemes in WR held on 29.08.2023

Sl. No.	Application ID	Name of the Applicant	Nature of Applicant	Submission Date	Energy Source	Eligibility Criteria	Region	Project Location	Connectivity location (requested)	Quantum (MW)	Connectivity sought from & Actual Start Date*	Dedicated Transmission System for Connectivity	Associated Transmission System for GNA	Common Transmission System Augmentation	BG Details
												<p>for its another WPP of 277MW (St-II Connectivity appl. no. 0231400018) with start date as 31.12.2025:</p> <ul style="list-style-type: none"> • RPSPL – Parli (New) 400kV S/c line (on D/c tower) along with 400kV line bay at generation end (Under the scope of applicant). • 1 no. 400kV line bay at Parli (New) S/s (Under the scope of ISTS) <p>Applicant stated that they shall confirm for Connectivity after taking up the matter with RSPPL and shall revert in 1 week time.</p> <p>M/s AEPL vide e-mail dated 13.09.2023 informed that the timeline of December 2025 for ISTS bay does not match their Project completion timeline (Dec-24). They have taken up the matter with M/s RPSPL and</p>			

Minutes of 2nd sitting of 21st Consultation meeting for Evolving Transmission Schemes in WR held on 29.08.2023

Sl. No.	Application ID	Name of the Applicant	Nature of Applicant	Submission Date	Energy Source	Eligibility Criteria	Region	Project Location	Connectivity location (requested)	Quantum (MW)	Connectivity sought from & Actual Start Date*	Dedicated Transmission System for Connectivity	Associated Transmission System for GNA	Common Transmission System Augmentation	BG Details
												requested to discuss the application in the next meeting. Accordingly, the application shall be deliberated again in the next meeting.			
8.	2200000081 (Revised Application)	Avaada Energy Private Limited (AEPL)	(i) Generating station(s), including REGS(s), without ESS	05-06-2023	Wind	Land BG Route	WR	Dhule, Maharashtra	Dhule (New Proposed)	50.0	30-06-2026 Actual: 30.06.2026	AEPL – Dhule PS (Sec-I) 220kV S/c line along with associated bay at AEPL end Bay at Dhule PS (Sec-I) end is included in scope of Dhule PS establishment (under tendering process)	NIL	<ul style="list-style-type: none"> Establishment of 4x500 MVA, 400/220 kV Pooling Station near Dhule Dhule PS – Dhule (BDTCL) 400 kV D/c Line (Quad ACSR/AAAC/AL59 Moose equivalent (60 km) Scheme is presently under bidding process with SPV transfer expected in Sep-23 and SCOD expected by Sep-25.	BG1: 50 Lakhs Conn-BG2: 3 Cr. Conn-BG-3: 1 Cr.
9.	2200000079 (Revised Application)	Avaada Energy Private Limited (AEPL)	(i) Generating station(s), including REGS(s), without ESS	05-06-2023	Wind	Land BG Route	WR	Dhar, Madhya Pradesh	Rajgarh (PG)	50.0	30-06-2025 Actual: 30.06.2025	It was informed that no further margins for injection exist at Rajgarh(PG) S/s. Hence, connectivity is proposed to be granted at Indore S/s (next nearest available substation) through below system: <ul style="list-style-type: none"> AEPL – Indore (PG) 765/400/220 kV S/s 220kV S/c line along with associated line bay at generation end (under the scope of 	NIL	NIL	BG1: 50 Lakhs Conn-BG2: As per terminal bay implementation Conn-BG-3: 1 Cr.

Minutes of 2nd sitting of 21st Consultation meeting for Evolving Transmission Schemes in WR held on 29.08.2023

Sl. No.	Application ID	Name of the Applicant	Nature of Applicant	Submission Date	Energy Source	Eligibility Criteria	Region	Project Location	Connectivity location (requested)	Quantum (MW)	Connectivity sought from & Actual Start Date*	Dedicated Transmission System for Connectivity	Associated Transmission System for GNA	Common Transmission System Augmentation	BG Details
												applicant) Implementation of 220 kV Hybrid /MTS line bay at Indore (PG) S/s (Double main scheme) end was to be deliberated.			
<p>Applicant stated that Indore S/s would be located ~100km. from the proposed project site and requested to be accommodated at Rajgarh S/s only through a dedicated 400/220kV 4th ICT (if required).</p> <p>It was informed that any further injection at 220kV level of Rajgarh S/s leads to overloading of downstream 220kV system of Rajgarh S/s. Non-availability of margins at Rajgarh S/s is also indicated on CTU website. Hence, it would not be possible to accommodate AEPL at 220kV level of Rajgarh S/s. However, POWERGRID would have to be consulted for accommodating additional 400/220kV ICT at Rajgarh S/s on 220kV new bus section (extended bus).</p> <p>It was decided that the application shall be deliberated again in the next meeting based on feedback from POWERGRID.</p>															
10.	2200000133 (Original Enhancement Application)	Sprng Akshaya Urja Private Limited (SAUPL)	(i) Generating station(s), including REGS(s), without ESS	27-06-2023	Wind	Land Route	WR	Dhar, Madhya Pradesh	Rajgarh (PG)	67.2	30-06-2025 Actual: 30.06.2025	As no further margins for injection exist at Rajgarh(PG) S/s, Connectivity was proposed to be granted at Indore(PG) S/s on sharing basis with application of AEPL which is proposed to be granted connectivity through system given above. However, based on request of applicant, the subject application was agreed to be deliberated again in next meeting along with	NIL	NIL	BG1: 50 Lakhs Conn-BG2: NIL Conn-BG-3: 1.344 Cr.

Minutes of 2nd sitting of 21st Consultation meeting for Evolving Transmission Schemes in WR held on 29.08.2023

Sl. No.	Application ID	Name of the Applicant	Nature of Applicant	Submission Date	Energy Source	Eligibility Criteria	Region	Project Location	Connectivity location (requested)	Quantum (MW)	Connectivity sought from & Actual Start Date*	Dedicated Transmission System for Connectivity	Associated Transmission System for GNA	Common Transmission System Augmentation	BG Details
												application of AEPL.			
11.	2200000076 (Revised Application)	NTPC Renewable Energy Limited	(i) Generating station(s), including REGS(s), without ESS	05-06-2023	Solar	PPA signed with SECI	WR	Nakhatrana, Kutch, Gujarat	Bhuj-II PS	300.0	31-03-2024 Actual: 31.03.2024	<ul style="list-style-type: none"> NTPC REL – Bhuj-II PS 220kV S/c line (on D/c tower) along with 220kV line bay at generation end (Under the scope of applicant). 220kV line bay at Bhuj-II PS is already existing. 	NIL	NIL	BG1: 50 Lakhs Conn-BG2: 3 Cr. Conn-BG-3: 6 Cr.
12.	2200000084 (Revised Application)	NTPC Renewable Energy Limited (refer Note)	(i) Generating station(s), including REGS(s), without ESS	09-06-2023	Wind	LOA (SECI)	WR	Devisar, Kutch, Gujarat	Bhuj-II PS	150.0	11-01-2025 Actual: 11.01.2025	<ul style="list-style-type: none"> NTPC REL – Bhuj-II PS 220kV S/c line (on D/c tower) along with 220kV line bay at generation end (Under the scope of applicant). 220kV line bay at Bhuj-II PS is already existing. 	NIL	NIL	BG1: 50 Lakhs Conn-BG2: 3 Cr. Conn-BG-3: 3 Cr.
<p>Following was informed w.r.t. above application of NTPC REL:</p> <ul style="list-style-type: none"> NTPC Renewable Energy Limited has applied for 150 MW Connectivity at Bhuj-II PS though sharing of switchyard of Inox Green Energy Services Limited (IGESL) already having 300 MW Connectivity at Bhuj-II PS. Applicant has submitted model agreement as per FORMAT-CONN-LEAD (instead of FORMAT-CONN-SHARE) wherein IGESL is Lead generator. IGESL has been granted 1 no. of 220kV bay at Bhuj-II PS for 220kV S/c (on D/c Tower) dedicated transmission line. As per the lead generator agreement, NTPC REL shall be sharing only the IGESL's 220kV Pooling Station & D/c tower infrastructure and lead generator and/or individual developers can apply for Connectivity. Further, in the Lead Generator agreement, it has been mentioned that applicant shall be sharing the above infrastructure of IGESL for 150MW under present application along with another application of 200MW of NTPC REL (yet to be applied) i.e. for total of 650MW capacity. However, applicant has applied present application under Reg. 5.6. for sharing of switchyard of IGESL which seems to be applicable in case of sharing switchyard along with dedicated transmission lines / ISTS bays. Subsequently, NTPC REL has applied for connectivity for 200MW (Appl. No. 2200000154) in July-23 wherein it has been mentioned that above two wind projects (cumulative capacity 350 MW) are located very near to each other are being developed with common Pooling sub-station at wind Plant end and common evacuation system/Transmission system for the two projects upto ISTS Substation. They have proposed that both wind projects shall share the same ISTS bay at ISTS Bhuj-II Substation. However, connectivity application of 200MW wind project is being submitted in standalone manner as "FORMAT-CONN-SHARE" under clause 5.7 of GNA Regulations, 2022 is for two or more different Companies. The format may not be applicable as NTPC REL is the applicant in both projects. Applicant has also submitted undertaking stating as follows: <p>"NTPC REL agree that one of the above project (150 MW Wind project at Devisar) shall act as Lead generator on behalf of second project mentioned above (200 MW wind project at Devisar) and perform all operational and</p>															

Minutes of 2nd sitting of 21st Consultation meeting for Evolving Transmission Schemes in WR held on 29.08.2023

Sl. No.	Application ID	Name of the Applicant	Nature of Applicant	Submission Date	Energy Source	Eligibility Criteria	Region	Project Location	Connectivity location (requested)	Quantum (MW)	Connectivity sought from & Actual Start Date*	Dedicated Transmission System for Connectivity	Associated Transmission System for GNA	Common Transmission System Augmentation	BG Details
<p>commercial responsibilities for the both proposed wind generating plant connected at that point following the provisions of IEGC and all other regulations of the Commission, related to grid security, scheduling and dispatch, collection and payment or adjustment of transmission charges, deviation charges, congestion and other charges etc. However, above Wind Projects will be considered as separate "User" for which energy accounts need to be issued separately."</p> <p>Applicant was requested to clarify.</p> <p>Representative of NTPC REL stated that same switchyard is being used by both Inox & NTPC REL and just for reliability considerations, the bus sectionaliser between the switchyards of Inox and NTPC REL is proposed to be closed to cater to contingency conditions. However, there will be no sharing of DTL with Inox.</p> <p>CTU stated that this may lead to complications w.r.t. metering and accounting and needs to be discussed with WRLDC before implementation. After deliberations, it was agreed to grant connectivity to NTPC REL with transmission system given above.</p>															
13.	220000080 (Revised Enhancement Application)	Juniper Green Ray Two Private Limited (JGR2PL)	(i) Generating station(s), including REGS(s), without ESS	08-06-2023	Solar	Land Route	WR	Solapur, Maharashtra	Solapur PS	50.0	30-06-2027 Actual: 30.06.2027	JGR2PL shall share Dedicated Transmission System for Connectivity granted to JGR2PL for its another SPP of 80MW (St-II Connectivity appl. no. 1671202687184) as given below: <ul style="list-style-type: none"> JGR2PL – Solapur PS 220kV S/c line along with associated bay at generation end 1 no. 220kV line bay at Solapur PS shall be implemented under ISTS as part of the pooling station. 	NIL	<ul style="list-style-type: none"> Establishment of 400/220 kV, 4x500 MVA ICTs at Solapur PS Solapur PS – Solapur (PG) 400 kV D/c line (Quad ACSR/AAAC/AL59 moose equivalent) <p>Tentative Commissioning schedule of the above transmission system: 30.09.2025. (Presently under tendering)</p>	BG1: 50 Lakhs; Conn-BG2: NIL Conn-BG-3: 1 Cr.
14.	2200000132 (Original Application)	Avaada Energy Private Limited (AEPL)	(i) Generating station(s), including REGS(s), without ESS	27-06-2023	Hybrid (RHGS)	Land BG Route	WR	Jawli, Solapur, Maharashtra	Solapur PS	50.0	31-12-2025 Actual: 31.12.2025	<ul style="list-style-type: none"> AEPL - Solapur PS 220kV S/c line along with associated bay at generation end 	NIL	<ul style="list-style-type: none"> Establishment of 400/220 kV, 4x500 MVA ICTs at Solapur PS Solapur PS – Solapur (PG) 400 kV D/c line (Quad 	BG1: 50 Lakhs Conn-BG2: 3 Cr.

Minutes of 2nd sitting of 21st Consultation meeting for Evolving Transmission Schemes in WR held on 29.08.2023

Sl. No.	Application ID	Name of the Applicant	Nature of Applicant	Submission Date	Energy Source	Eligibility Criteria	Region	Project Location	Connectivity location (requested)	Quantum (MW)	Connectivity sought from & Actual Start Date*	Dedicated Transmission System for Connectivity	Associated Transmission System for GNA	Common Transmission System Augmentation	BG Details
												<p>(Under scope of applicant)</p> <ul style="list-style-type: none"> 1 no. 220kV line bay at Solapur PS shall be implemented under ISTS as part of the pooling station. <p>The separate bay was agreed for AEPL based on commitment that they shall enhance their connectivity quantum progressively to 300MW.</p>		<p>ACSR/AAAC/AL59 moose equivalent)</p> <p>Tentative Commissioning schedule of the above transmission system: 30.09.2025. (Presently under tendering)</p>	Conn-BG-3: 1 Cr.
15.	2200000093 (Revised Application)	NTPC Renewable Energy Limited	(x) Renewable Power Park developer	14-06-2023	Solar	Land Route	WR	Kutch, Gujarat	Khavda PS-II	1995.0	30-06-2025	<ul style="list-style-type: none"> NTPC REL PS (South) – Khavda-II PS (Sec-I) 400kV D/c (Quad ACSR/AAAC/AL59 moose equivalent) line along with associated bay at Generation end (Under the scope of applicant) Bays at ISTS substation end shall be under the scope of ISTS@ <p>Actual: 31.01.2026 (based on expected schedule of Common Augmentation & 400kV bays at KPS2)</p>	NIL	<p>Khavda Phase-I:</p> <ul style="list-style-type: none"> KPS1 – Bhuj 765kV D/c line KPS1 – KPS2 765kV D/c line <p>Establishment of KPS2 in Khavda RE Park:</p> <ul style="list-style-type: none"> Establishment of 765/400kV, 4x1500MVA, KPS2(GIS) <p>Khavda Phase-II:</p> <ul style="list-style-type: none"> KPS2 – Lakadia 765kV D/c line Establishment of 3x1500 MVA, 765/400 kV Ahmedabad S/s Lakadia – Ahmedabad 765kV D/c line Ahmedabad – Navsari (New) 765kV D/c line LILO of Pirana (PG) – Pirana (T) 400kV D/c line at 	BG1: 50 Lakhs Conn-BG2: 12 Cr. Conn-BG-3: 39.9 Cr.

Minutes of 2nd sitting of 21st Consultation meeting for Evolving Transmission Schemes in WR held on 29.08.2023

Sl. No.	Application ID	Name of the Applicant	Nature of Applicant	Submission Date	Energy Source	Eligibility Criteria	Region	Project Location	Connectivity location (requested)	Quantum (MW)	Connectivity sought from & Actual Start Date*	Dedicated Transmission System for Connectivity	Associated Transmission System for GNA	Common Transmission System Augmentation	BG Details
												<p>@Additional bays are being implemented with Khavda Ph-IV Part E2 scheme (approved in 14th NCT with schedule of 21 months)</p>		<p>Ahmedabad S/s with twin HTLS along with reconductoring of Pirana (PG) – Pirana(T) line with twin HTLS conductor and Bay upgradation work at Pirana (PG) & Pirana (T)</p> <p>Above system forms part of Existing ISTS for the purpose of CERC GNA Regulations, 2022</p> <p>Khavda Phase-III:</p> <ul style="list-style-type: none"> Establishment of 765 kV Halvad switching station KPS2- Halvad 765 kV D/c line LILO of Lakadia – Ahmedabad 765 kV D/c line at Halvad Halvad – Vataman 765 kV D/c line Establishment of 765 kV switching station near Vataman LILO of Lakadia – Vadodara 765 kV D/c line at Vataman 765 kV switching station Vataman switching station – Navsari(New) 765 kV D/c line <p>Khavda Phase-IV</p> <ul style="list-style-type: none"> Creation of 765kV bus section-II at KPS3 (GIS) along with 765kV Bus Sectionaliser Creation of 400kV bus section-II at KPS3 (GIS) 	

Minutes of 2nd sitting of 21st Consultation meeting for Evolving Transmission Schemes in WR held on 29.08.2023

Sl. No.	Application ID	Name of the Applicant	Nature of Applicant	Submission Date	Energy Source	Eligibility Criteria	Region	Project Location	Connectivity location (requested)	Quantum (MW)	Connectivity sought from & Actual Start Date*	Dedicated Transmission System for Connectivity	Associated Transmission System for GNA	Common Transmission System Augmentation	BG Details
														along with 400kV Bus Sectionalizer <ul style="list-style-type: none"> • KPS3 (GIS) – Lakadia (AIS) 765 kV D/C line • ±300MVar STATCOM with 1x125 MVar MSC, 2x125 MVar MSR at KPS3 400kV Bus section-2 • KPS1 (GIS)– Bhuj PS 765 kV 2nd D/C line • Establishment of 2x1500MVA, 765/400kV & 2x500MVA, 400/220kV GIS S/s at a suitable location South of Olpad (between Olpad and Ichhapore) • Vadodara(GIS) –South Olpad(GIS) 765 kV D/C line • LILO of Gandhar – Hazira 400kV D/c line at South Olpad (GIS) using twin HTLS conductor with minimum capacity of 1700MVA per ckt at nominal voltage • Ahmedabad – South Olpad(GIS) 765kV D/c line • Establishment of 4X1500 MVA 765/400 kV & 2x500MVA 400/220kV Boisar-II (GIS) • South Olpad(GIS) – Boisar-II(GIS) 765kV D/c line • LILO of Navsari(New) – Padghe(PG) 765kV D/c line at Boisar-II • Boisar-II (Sec-II) – Velgaon(MH) 400kV D/c (Quad ACSR/AAAC/AL59 moose equivalent) line • LILO of Babhaleswar – Padghe(M) 400kV D/c line at 	

Minutes of 2nd sitting of 21st Consultation meeting for Evolving Transmission Schemes in WR held on 29.08.2023

Sl. No.	Application ID	Name of the Applicant	Nature of Applicant	Submission Date	Energy Source	Eligibility Criteria	Region	Project Location	Connectivity location (requested)	Quantum (MW)	Connectivity sought from & Actual Start Date*	Dedicated Transmission System for Connectivity	Associated Transmission System for GNA	Common Transmission System Augmentation	BG Details
														<p>Boisar-II (Sec-I) using twin HTLS conductor with minimum capacity of 1700MVA per ckt at nominal voltage</p> <ul style="list-style-type: none"> ±200MVar STATCOM with 2x125 MVar MSC, 1x125 MVar MSR at 400 kV bus section-I of Boisar-II and ±200MVar STATCOM with 2x125 MVar MSC, 1x125 MVar MSR at 400 kV bus section-II of Boisar-II ± 300 MVar STATCOM with 3x125 MVar MSC, 1x125 MVar MSR at 400 kV level of Navsari(New)(PG) S/s with 1 No. of 400 kV bay (GIS) Establishment of 2X1500 MVA 765/400 kV & 3x500MVA 400/220kV Pune-III (GIS) Boisar-II – Pune-III 765kV D/c line LILO of Narendra(New) – Pune(GIS) 765kV D/c line at Pune-III LILO of Hinjewadi-Koyna 400kV S/c line at Pune-III(GIS) S/s Augmentation of transformation capacity at Padghe (GIS) 765/400 kV substation by 1x1500 MVA ICT (4th) along with associated bays <p>KPS2 Augmentation Scheme (Khavda Ph-IV Part E-2):</p> <ul style="list-style-type: none"> Augmentation of transformation capacity at KPS2 (GIS) by 2x1500 	

Minutes of 2nd sitting of 21st Consultation meeting for Evolving Transmission Schemes in WR held on 29.08.2023

Sl. No.	Application ID	Name of the Applicant	Nature of Applicant	Submission Date	Energy Source	Eligibility Criteria	Region	Project Location	Connectivity location (requested)	Quantum (MW)	Connectivity sought from & Actual Start Date*	Dedicated Transmission System for Connectivity	Associated Transmission System for GNA	Common Transmission System Augmentation	BG Details
														MVA, 765/400 kV ICT on Bus section-I (5th & 6th) & 2x1500 MVA, 765/400 kV ICT on Bus section-II (7th & 8th) [Anticipated completion schedule of the above transmission system: Progressively by 31.01.2026 (expected)]	
Representative of NTPC REL requested if the date of commissioning of ISTS end bays could be mentioned in the intimation so that date of Connectivity (without entire GNA system) could also be available with them.															
It was informed that the details of commissioning of dedicated transmission system for connectivity is already mentioned above and the same would also be mentioned in the intimation.															
16.	2200000131 (Original Application)	Avaada Energy Private Limited (AEPL)	(i) Generating station(s), including REGS(s), without ESS	26-06-2023	Solar	LOA (RECP DCL) under scheme for flexibility in Generation and Scheduling of Thermal/Hydro Power Station through bundling with RE and Storage Power. As per RfP docum	WR	Rampar, Katch, Gujarat	Lakadia PS	300.0	31-12-2024 <u>Actual: Based on availability of ATS.</u>	It was proposed that AEPL shall share the Dedicated Transmission System for Connectivity proposed to be granted to Avaada Inclean Pvt Ltd. (AIPL) for its SPP of 50MW (GNA Connectivity appl. no. 2200000011) as given below: • AEPL – Lakadia 220kV S/c line along with associated bay at Generation end. (Under the scope of applicant). Implementation of 220kV bay at Lakadia S/s is	• Establishment of 1x500MV A, 400/220kV ICT at Lakadia PS along with 220kV switchyard and associated ICT bays	NIL	Conn-BG1: 50 Lakhs Conn-BG2: As per ATS / terminal bay

Minutes of 2nd sitting of 21st Consultation meeting for Evolving Transmission Schemes in WR held on 29.08.2023

Sl. No.	Application ID	Name of the Applicant	Nature of Applicant	Submission Date	Energy Source	Eligibility Criteria	Region	Project Location	Connectivity location (requested)	Quantum (MW)	Connectivity sought from & Actual Start Date*	Dedicated Transmission System for Connectivity	Associated Transmission System for GNA	Common Transmission System Augmentation	BG Details
						ent, RECP DCL is working as bid processes coordinator on behalf of procurer i.e., DVC						<p>agreed under ISTS.</p> <p>However, the Applicant submitted that they have already made application for another 200MW at Lakadia PS in Aug-23 and requested to club this 200MW application with 50MW application discussed earlier. Further, applicant requested for separate 220kV bay for subject application for 300MW.</p> <p>The request of applicant was agreed and Dedicated Transmission System for Connectivity is as given below:</p> <ul style="list-style-type: none"> • AEPL – Lakadia 220kV S/c line along with associated bay at Generation end. (Under the scope of applicant). <p>Implementation of 220kV bay at Lakadia S/s is agreed under ISTS.</p>			

Minutes of 2nd sitting of 21st Consultation meeting for Evolving Transmission Schemes in WR held on 29.08.2023

Sl. No.	Application ID	Name of the Applicant	Nature of Applicant	Submission Date	Energy Source	Eligibility Criteria	Region	Project Location	Connectivity location (requested)	Quantum (MW)	Connectivity sought from & Actual Start Date*	Dedicated Transmission System for Connectivity	Associated Transmission System for GNA	Common Transmission System Augmentation	BG Details
17.	2200000142 (Original Application)	Avaada Energy Private Limited (AEPL)	(i) Generating station(s), including REGS(s), without ESS	29-06-2023	Hybrid (RHGS)	Land BG Route	WR	Dev Bhoomi Dwarka, Gujarat	Jam Khambhaliya PS	50.0	30-09-2025 Actual: 30.09.2025	Considering the small quantum of 50MW, AEPL was requested to share the transmission infrastructure with one of the other applicants in the area viz. POWERICA(103.6 MW), Torrent Power (115MW) or Apraava (250.71MW). However, the applicant requested for a separate bay considering that they shall be applying for enhancement of their connectivity quantum by 200-250MW in Sep-23. In view of the above, dedicated connectivity system was agreed as under: <ul style="list-style-type: none"> • AEPL – Jam Khambhaliya PS 220kV S/c line along with associated bay at generation end • 1 no. 220kV line bay at Jam Khambhaliya 	NIL	NIL	BG1: 50 Lakhs Conn-BG2: 3 Cr. Conn-BG-3: 1 Cr. Applicant stated that they intend to apply for enhancement of their connectivity quantum by 200-250MW in Sep-23.

Sl. No.	Application ID	Name of the Applicant	Nature of Applicant	Submission Date	Energy Source	Eligibility Criteria	Region	Project Location	Connectivity location (requested)	Quantum (MW)	Connectivity sought from & Actual Start Date*	Dedicated Transmission System for Connectivity	Associated Transmission System for GNA	Common Transmission System Augmentation	BG Details
												PS has been implemented under ISTS as part of the pooling station.			

**The date of commencement of Connectivity under GNA is Interim. The timeline for completion of ATS/ Common Transmission System Augmentation / Terminal bay(s) (if not under implementation) as applicable along with firm date for start of connectivity shall be intimated within 6 months of furnishing of Conn-BG 1 (in case of Augmentation with ATS) and Conn-BG1, Conn-BG2 & Conn-BG3, (as applicable, in case of Augmentation without ATS) in line with Regulation 8.3 b of GNA Regulations.*

After deliberations, it was agreed to grant connectivity to the above applicants as per the proposal given in table above. Further following was informed to the applicants:

- Liability of payment of applicable transmission charges shall as per CERC sharing Regulations, 2020.
- Wherever ATS / Terminal Bay at ISTS end is being implemented by ISTS Licensee as per intimation for grant of connectivity under GNA regulation, in case, COD of the ATS / Terminal bay of Connectivity line is achieved earlier than COD of the Generation project (but not earlier than the start date of Connectivity under GNA), the liability of payment of applicable transmission charges for such mismatch period shall be governed by CERC Sharing Regulations, 2020.

The above was noted and agreed.

d) Jul-23

Minutes of 2nd sitting of 21st Consultation meeting for Evolving Transmission Schemes in WR held on 29.08.2023

Sl. No.	Application ID	Name of the Applicant	Nature of Applicant	Submission Date	Energy Source	Eligibility Criteria	Region	Project Location	Connectivity location (requested)	Quantum (MW)	Connectivity sought from & Actual Start Date*	Dedicated Transmission System for Connectivity	Associated Transmission System for GNA	Common Transmission System Augmentation	BG Details
1.	2200000159 (Revised Enhancement Application)	Gujarat Industries Power Company Ltd.	(x) Renewable Power Park developer	29-07-2023	Solar	Land Route	WR	Kutch, Gujarat	Khavda - II PS	1775	31-12-2024 Actual: 31.12.2027	<p>For up to 575MW, GIPCL shall share the Dedicated Transmission System for Connectivity be granted to GIPCL for its SPP of 600MW (St-II Connectivity appl. no. 1200003371) as given below:</p> <ul style="list-style-type: none"> GIPCL PS1 – Khavda-II PS (Sec-I) 400kV S/c line (on D/c tower) alongwith associated line bay at generating station (under the scope of applicant) Bay at ISTS substation end shall be under the scope of ISTS. (being implemented as part of KPS2 Establishment scheme) <p>For balance 1200MW:</p> <ul style="list-style-type: none"> GIPCL PS2 – Khavda-II PS (Sec-II) 400kV S/c line alongwith associated line bay at generating station (under the scope of applicant) <p>Bay at ISTS substation end shall be under the scope of ISTS. @ <i>Addl. Bays on Sec-II are being implemented with Khavda Ph-IV Part</i></p>	NIL	<p>Khavda Phase-I:</p> <ul style="list-style-type: none"> KPS1 – Bhuj 765kV D/c line KPS1 – KPS2 765kV D/c line <p>Establishment of KPS2 in Khavda RE Park:</p> <ul style="list-style-type: none"> Establishment of 765/400kV, 4x1500MVA, KPS2(GIS) <p>Khavda Phase-II:</p> <ul style="list-style-type: none"> KPS2 – Lakadia 765kV D/c line Establishment of 3x1500 MVA, 765/400 kV Ahmedabad S/s Lakadia – Ahmedabad 765kV D/c line Ahmedabad – Navsari (New) 765kV D/c line LILO of Pirana (PG) – Pirana (T) 400kV D/c line at Ahmedabad S/s with twin HTLS along with reconductoring of Pirana (PG) – Pirana(T) line with twin HTLS conductor and Bay upgradation work at Pirana (PG) & Pirana (T) <p>Above system forms part of Existing ISTS for the purpose of CERC GNA Regulations, 2022</p> <p>Khavda Phase-III:</p> <ul style="list-style-type: none"> Establishment of 765 kV Halvad switching station KPS2- Halvad 765 kV D/c line LILO of Lakadia – Ahmedabad 765 kV D/c line at Halvad Halvad – Vataman 765 kV D/c line Establishment of 765 kV switching station near Vataman 	BG1: 50 Lakhs Conn-BG2: 6 Cr. Conn-BG-3: 35.5 Cr.

Minutes of 2nd sitting of 21st Consultation meeting for Evolving Transmission Schemes in WR held on 29.08.2023

Sl. No.	Application ID	Name of the Applicant	Nature of Applicant	Submission Date	Energy Source	Eligibility Criteria	Region	Project Location	Connectivity location (requested)	Quantum (MW)	Connectivity sought from & Actual Start Date*	Dedicated Transmission System for Connectivity	Associated Transmission System for GNA	Common Transmission System Augmentation	BG Details
												<p><i>E2 scheme (approved in 14th NCT with schedule of 21 months)</i></p> <p>Note: <i>It was informed that Interconnection between GIPCL PS1 & PS2 (if any) shall be kept normally open and can be closed under contingency conditions only. GIPCL informed that at present, no interconnection between their PS1 & PS2 is planned. Nevertheless, they shall keep the above in mind while planning for the interconnection in future.</i></p>		<ul style="list-style-type: none"> LILO of Lakadia – Vadodara 765 kV D/c line at Vataman 765 kV switching station Vataman switching station – Navsari(New) 765 kV D/c line <p>Khavda Phase-IV</p> <ul style="list-style-type: none"> Creation of 765kV bus section-II at KPS3 (GIS) along with 765kV Bus Sectionaliser Creation of 400kV bus section-II at KPS3 (GIS) along with 400kV Bus Sectionaliser KPS3 (GIS) – Lakadia (AIS) 765 kV D/C line ±300MVAR STATCOM with 1x125 MVAR MSC, 2x125 MVAR MSR at KPS3 400kV Bus section-2 KPS1 (GIS)– Bhuj PS 765 kV 2nd D/C line Establishment of 2x1500MVA, 765/400kV & 2x500MVA, 400/220kV GIS S/s at a suitable location South of Olpad (between Olpad and Ichhapore) Vadodara(GIS) –South Olpad(GIS) 765 kV D/C line LILO of Gandhar – Hazira 400kV D/c line at South Olpad (GIS) using twin HTLS conductor with minimum capacity of 1700MVA per ckt at nominal voltage Ahmedabad – South Olpad(GIS) 765kV D/c line Establishment of 4X1500 MVA 765/400 kV & 2x500MVA 400/220kV Boisar-II (GIS) South Olpad(GIS) – Boisar-II(GIS) 765kV D/c line 	

Minutes of 2nd sitting of 21st Consultation meeting for Evolving Transmission Schemes in WR held on 29.08.2023

Sl. No.	Application ID	Name of the Applicant	Nature of Applicant	Submission Date	Energy Source	Eligibility Criteria	Region	Project Location	Connectivity location (requested)	Quantum (MW)	Connectivity sought from & Actual Start Date*	Dedicated Transmission System for Connectivity	Associated Transmission System for GNA	Common Transmission System Augmentation	BG Details
														<ul style="list-style-type: none"> • LILO of Navsari (New) – Padghe(PG) 765kV D/c line at Boisar-II • Boisar-II (Sec-II) – Velgaon(MH) 400kV D/c (Quad ACSR/AAAC/AL59 moose equivalent) line • LILO of Babhaleswar – Padghe(M) 400kV D/c line at Boisar-II (Sec-I) using twin HTLS conductor with minimum capacity of 1700MVA per ckt at nominal voltage • ±200MVAR STATCOM with 2x125 MVAR MSC, 1x125 MVAR MSR at 400 kV bus section-I of Boisar-II and ±200MVAR STATCOM with 2x125 MVAR MSC, 1x125 MVAR MSR at 400 kV bus section-II of Boisar-II • ± 300 MVAR STATCOM with 3x125 MVAR MSC, 1x125 MVAR MSR at 400 kV level of Navsari (New)(PG) S/s with 1 No. of 400 kV bay (GIS) • Establishment of 2X1500 MVA 765/400 kV & 3x500MVA 400/220kV Pune-III (GIS) • Boisar-II – Pune-III 765kV D/c line • LILO of Narendra(New) – Pune(GIS) 765kV D/c line at Pune-III • LILO of Hinjewadi-Koyna 400kV S/c line at Pune-III(GIS) S/s • Augmentation of transformation capacity at Padghe (GIS) 765/400 kV substation by 1x1500 MVA ICT (4th) along with associated bays <p>KPS2 Augmentation Scheme (Khavda Ph-IV Part E-2):</p>	

Minutes of 2nd sitting of 21st Consultation meeting for Evolving Transmission Schemes in WR held on 29.08.2023

Sl. No.	Application ID	Name of the Applicant	Nature of Applicant	Submission Date	Energy Source	Eligibility Criteria	Region	Project Location	Connectivity location (requested)	Quantum (MW)	Connectivity sought from & Actual Start Date*	Dedicated Transmission System for Connectivity	Associated Transmission System for GNA	Common System Augmentation	Transmission	BG Details
														<ul style="list-style-type: none"> Augmentation of transformation capacity at KPS2 (GIS) by 2x1500 MVA, 765/400 kV ICT on Bus section-I (5th & 6th) & 2x1500 MVA, 765/400 kV ICT on Bus section-II (7th & 8th) <p>Khavda Phase-V</p> <p>Part A (Bipole-1)</p> <ul style="list-style-type: none"> Establishment of 3000 MW, ± 800 kV KPS2 (HVDC) [LCC] terminal station (2x1500 MW) Establishment of 3000 MW, ± 800 kV Nagpur (HVDC) [LCC] terminal station (2x1500 MW) ±800 kV HVDC Bipole line (Hexa lapwing) between KPS2 (HVDC) and Nagpur (HVDC) (1200 km) Establishment of 6x1500 MVA, 765/400 kV ICTs at Nagpur S/s LILO of Wardha – Raipur 765 kV one D/c line (out of 2xD/c lines) at Nagpur <p>OR</p> <p>Part C</p> <ul style="list-style-type: none"> Establishment of 2500 MW, ± 500 kV KPS3 (HVDC) [VSC] terminal station (2x1250 MW) at a suitable location near KPS3 Establishment of 2500 MW, ± 500 kV South Olpad (HVDC) [VSC] terminal station (2x1250 MW) Establishment of KPS3 (HVDC) S/s KPS3 – KPS3 (HVDC) 400 kV 2xD/c (Quad) 		

Minutes of 2nd sitting of 21st Consultation meeting for Evolving Transmission Schemes in WR held on 29.08.2023

Sl. No.	Application ID	Name of the Applicant	Nature of Applicant	Submission Date	Energy Source	Eligibility Criteria	Region	Project Location	Connectivity location (requested)	Quantum (MW)	Connectivity sought from & Actual Start Date*	Dedicated Transmission System for Connectivity	Associated Transmission System for GNA	Common Transmission System Augmentation	BG Details
														<p>ACSR/AAAC/AL59 moose equivalent) line</p> <ul style="list-style-type: none"> ±500 kV HVDC Bipole line between KPS3 (HVDC) and South Olpad (HVDC) <p>AND</p> <p>Part B</p> <ul style="list-style-type: none"> Augmentation of transformation capacity at KPS2 (GIS) by 1x1500 MVA, 765/400 kV ICT on Bus Section I (9th) <p>[Anticipated completion schedule of the above transmission system: Progressively by 31.12.2027 (expected)]</p>	
2.	2200000155 (Revised Enhancement Application)	Renew Green Energy Solutions Private Limited (RGESL)	(i) Generating station(s), including REGS(s), without ESS	26-07-2023	Wind	Land Route	WR	Latur Osmanabad Maharashtra	Solapur PS	73.0	30-09-2024 Actual: 30.09.2025	RGESL shall share the dedicated Transmission System for Connectivity of M/s ReNew Green Energy Solutions Pvt. Ltd. (RGESL) with applicant no. 0231400007) as given below: <ul style="list-style-type: none"> RGESL PSS 4 – Solapur (PG) 400kV S/c line (on D/c tower) (with HTLS conductor with minimum capacity of 2100MW at nominal voltage) along with associated by at 	NIL	NIL	BG1: 50 Lakhs; Conn-BG2: NIL Conn-BG-3: 1.46 Cr.

Minutes of 2nd sitting of 21st Consultation meeting for Evolving Transmission Schemes in WR held on 29.08.2023

Sl. No.	Application ID	Name of the Applicant	Nature of Applicant	Submission Date	Energy Source	Eligibility Criteria	Region	Project Location	Connectivity location (requested)	Quantum (MW)	Connectivity sought from & Actual Start Date*	Dedicated Transmission System for Connectivity	Associated Transmission System for GNA	Common System Augmentation	Transmission	BG Details
												<p>both ends (under the scope of applicant) [Solapur PS: Bay no. 433 (400kV AIS- One and Half Breaker Scheme)]</p> <p>Interconnection between RGESL main pooling station (PSS 4) and intermediate pooling stations (under the scope of applicant):</p> <ul style="list-style-type: none"> • Establishment of 33/400kV Pooling Sub-statin PSS1 • Establishment of 33/400kV Pooling Sub-statin PSS2 • Establishment of 33/400kV Pooling Sub-statin PSS3 • PSS 3 – PSS 1 400kV S/c line (on D/c tower) along with associated bays • PSS 2 – PSS 1 400kV S/c line (on D/c towers) along with associated bays • PSS 1 – PSS 4 400kV S/c line (on 				

Minutes of 2nd sitting of 21st Consultation meeting for Evolving Transmission Schemes in WR held on 29.08.2023

Sl. No.	Application ID	Name of the Applicant	Nature of Applicant	Submission Date	Energy Source	Eligibility Criteria	Region	Project Location	Connectivity location (requested)	Quantum (MW)	Connectivity sought from & Actual Start Date*	Dedicated Transmission System for Connectivity	Associated Transmission System for GNA	Common System Augmentation	Transmission	BG Details
												D/c towers) along with associated bays				
3.	2200000154 (Original Application)	NTPC Renewable Energy Limited	(i) Generating station(s), including REGS(s), without ESS	13-07-2023	Wind	LOA (SECI Tr-XII)	WR	Devisar, Kutch, Gujarat	Bhuj-II PS	200.0 (Sharing with 150MW project)	29-03-2025 Actual: 29.03.2025	NTPC REL shall share the Dedicated Transmission System for Connectivity proposed to be granted to NTPC REL for its WPP of 150MW (GNA Connectivity appl. no. 2200000084) as given below: <ul style="list-style-type: none"> NTPC REL – Bhuj-II PS 220kV S/c line along with 220kV line bay at generation end (Under the scope of applicant). 220kV line bay at Bhuj-II PS is already existing. 	NIL	NIL		BG1: 50 Lakhs; Conn-BG2: NIL. Conn-BG-3: 4 Cr
Note: Refer deliberations at Sl. 12 of NTPC REL (150MW) of Jun-23 applications																
4.	2200000177 (Original Application)	The Tata Power Company Limited	(vii) Standalone ESS	29-07-2023	Pump Storage	NA	WR	Bhivpuri, Raigad, Maharashtra	Talegaon (Pune) S/s	1150.0	31-12-2026	It was informed that the connectivity applications have been received from from M/s Tata Power Company Limited for Standalone ESS based projects with capacity (pumping mode) of 1150MW in Bhivpuri, Raigad, Maharashtra & 1980MW in Khandshi, Pune, Maharashtra seeking connectivity at Pune (PG) S/s. However, as per communication from CEA and various other PSP developers, it has been informed that the terrain in the adjoining areas are such that it is suitable for PSP potential. Thus, in order to develop a comprehensive network plan for evacuation of power from the Tata Power PSPs including other future PSPs based on potential in the Western ghats of Maharashtra, CEA has been requested details of other PSPs identified in the area vide e-mail dated 10.08.2023. Upon receipt of the data from CEA, the transmission system for above PSPs shall be finalised in consultation with various stakeholders in WR. Applicant noted the same.				
5.	2200000176 (Original Application)	The Tata Power Company Limited	(vii) Standalone ESS	29-07-2023	Pump Storage	NA	WR	Khandshi, Pune, Maharashtra	Talegaon (Pune) S/s	1980.0	31-12-2026					

**The date of commencement of Connectivity under GNA is Interim. The timeline for completion of ATS/ Common Transmission System Augmentation /Terminals bay(s) (if not under implementation) as applicable along with firm date for start of connectivity shall be intimated within*

6 months of furnishing of Conn-BG 1 (in case of Augmentation with ATS) and Conn-BG1, Conn-BG2 & Conn-BG3, (as applicable, in case of Augmentation without ATS) in line with Regulation 8.3 b of GNA Regulations.

After deliberations, it was agreed to grant connectivity to the above applicants as per the proposal given in table above. Further following was informed to the applicants:

- Liability of payment of applicable transmission charges shall as per CERC sharing Regulations, 2020.
- Wherever ATS / Terminal Bay at ISTS end is being implemented by ISTS Licensee as per intimation for grant of connectivity under GNA regulation, in case, COD of the ATS / Terminal bay of Connectivity line is achieved earlier than COD of the Generation project (but not earlier than the start date of Connectivity under GNA), the liability of payment of applicable transmission charges for such mismatch period shall be governed by CERC Sharing Regulations, 2020.

The above was noted and agreed.

It was informed that based on proposal for grant of connectivity under GNA to various applicants at KPS2 S/s in Khavda area of Gujarat (as discussed in this meeting), the following table may be referred for segregation of applicants among the two 400kV sections of KPS2:

Sl. No.	Name of Applicant (Organization)	RE Pooling Station	Connectivity Quantum (MW)	Application No.	Remarks
1	Gujarat State Electricity Corporation Limited	KPS2	600	1200003331	
2	Gujarat Industries Power Company Limited	KPS2	600	1200003371	
3	Gujarat State Electricity Corporation Limited	KPS2	1000	230700005	
4	NTPC Renewable Energy Limited	KPS2	1995	2200000093 (GNA)	
5	Gujarat State Electricity Corporation Limited	KPS1	364	2200000048 (GNA)	Out of 1725MW application
6	Gujarat Industries Power Company Ltd	KPS2	575	2200000159 (GNA)	Out of 1775MW application
	KPS2 Section-I (6GW)		5134		
7	NTPC Renewable Energy Ltd	KPS2	265	1200003585	
8	NTPC Renewable Energy Ltd	KPS2	100	1200003733	

9	NTPC Renewable Energy Ltd	KPS2	890	1200003953	
10	NTPC Renewable Energy Ltd (NTPC REL)	KPS2	300	330700007	
11	Gujarat State Electricity Corporation Limited	KPS2	1361	2200000048 (GNA)	Out of 1725MW application
12	Gujarat Industries Power Company Ltd	KPS2	1200	2200000159 (GNA)	Out of 1775MW application
	KPS2 Section-II (4.5GW)		4116		
	Khavda PS-II Total		9250		

It was further informed that since the 400kV bus sections I & II of KPS2 are to be kept normally open, the various RE generating stations, which are proposed to be interconnected at both of the above bus sections, must note that they shall keep their generating end Pooling Station bus sections segregated & normally open in a manner so as to ensure that there is no interconnection between KPS2 Bus sections-1 & 2 via their generating end Pooling Stations.

Further, all those applicants (Apr-23 to Jul-23) who had requested regarding implementation of 220kV S/c dedicated line upto ISTS S/s on double circuit / Multi circuit towers were requested to forward an undertaking as finalized by CEA & CTU (on company letter head) stating below mentioned text within one week of the meeting:

Quote

1. *<Developer/s> would implement the connectivity line on Double Circuit and / or on Multi Circuit towers at their own cost & risk.*
2. *The <developer/s> would not make any claim for additional bay or additional quantum of injection or overriding priority at the ISTS pooling station on basis of point at Sl. no. 1.*
3. *All issues related to sharing of the Double Circuit and / or Multi Circuit towers has to be coordinated among the developers themselves under intimation to CEA / CTU before taking up implementation.*
4. *<Applicant> shall not claim any compensation/change in commissioning schedule/Connectivity Start Date/dedicated transmission line completion timeline due to Connectivity line on Double Circuit and / or on Multi Circuit tower*

Unquote

It was also informed to all applicants that for optimization of ROW, it is proposed that transmission towers of various **dedicated lines, up to 2-3 km periphery from the entry of the pooling station may be of Multi-circuit type**. The generation developers/applicants

associated with the various pooling stations may coordinate amongst themselves for implementation of such span/stretch of the dedicated connectivity lines with M/C towers.

The above was noted and agreed.

II. Applications for Grant of GNA/GNARE to entities other than STU under Regulation 20.1, 20.3 and 20.4 to entities under Regulation 17.1(ii), (iii), (v) and (vi)

a) Apr-23

Sl. No.	Application ID	Name of the Applicant	Submission Date	Region	Applied for GNA/GNARE	Nearest ISTS sub-station	Nature of applicant	GNA within Region (MW)	GNA outside Region (MW)	Total Quantum (MW) of GNA Required	Start date of GNA sought / Actual*	End date of GNA	Conn-BG required
1.	2200000023 (Revised Application)	Torrent Power Ltd. (TPL-Surat, Gujarat)	26-04-2023	WR	GNA	Sugen (400kV) S/s	Distribution licensee seeking to connect to ISTS	50.0	50.0	100	01-05-2023 / 01.10.2023#	30-04-2026	Conn-BG1: 50 Lakhs Conn-BG3: 2 Cr.
2.	2200000017 (Revised Application)	Torrent Power Ltd. (TPL-Ahmedabad, Gujarat) ^	26-04-2023	WR	GNA	TPL- Pirana (400kV) -S/s and Nicol-2 (400KV) TPL S/s	Distribution licensee seeking to connect to ISTS	400.0	400.0	800	01-05-2023 / 01.10.2023#	30-04-2026	Conn-BG1: 50 Lakhs Conn-BG3: 16 Cr.

^ Applicant has submitted the Certificate of Incorporation regarding change of name of "The Ahmedabad Electricity Company Limited" to "Torrent Power AEC limited" and Order dated 12.07.2006 of High Court of Gujarat regarding sanction of scheme of amalgamation of "Torrent Power AEC Limited" with "Torrent Power Limited".

#CERC vide order dated 03.08.2023 notified that the CERC (Indian Electricity Grid Code) Regulations, 2023, shall come into force with effect from 01.10.2023. As scheduling and Despatch of electricity under GNA regulation shall be as per CERC (Indian Electricity Grid Code) Regulations, 2023, the effective date of deemed GNA considered to these applicants shall be with effect from 01.10.2023. Till that time Scheduling and Despatch of electricity shall continue to be

based on the quantum of Long-Term Access (LTA), Medium-Term Open Access (MTOA) and Short-Term Open Access (STOA) as per CERC notification dated 01.04.2023 (subject to submission of requisite BGs).

** Liability of payment of applicable transmission charges shall as per CERC sharing Regulations, 2020.*

In the 19th CMETS-WR meeting held on 30.05.2023, M/s TPL(Ahmedabad) informed that the Government of Gujarat (GoG) notification dated 22nd Oct'97 needs to be read with GoG letter dated 17th Dec'88 wherein extension was granted upto 2005. Accordingly, 20 years extension which is mentioned in the notification dated 22nd Oct'97 is from 2005. Hence, License is valid till 2025. The above is also mentioned at page no. 2 of the license, which shall be shared via e-mail. The hard copy of the license was submitted by TPL vide e-mail dated 30.05.2023. Further, Torrent Power Limited informed that it currently operates as distribution licensee at various locations including Ahmedabad and Hon'ble GERC is also determining tariff for Torrent Power Limited's Ahmedabad discom.

In this respect, it was noted that the current validity of license is till 2025 and the end date of GNA is April, 2026. Accordingly, the treatment of GNA beyond 2025 in case of non-extension of license granted to M/s TPL (Ahmedabad) needs to be discussed further in the ensuing meeting(s).

M/s TPL informed that the license is presently valid upto 2030 and they shall submit requisite documents in this respect after the meeting. Further, the license shall be extended beyond 2030 in line with earlier extensions given by GoG from time to time.

With respect to above applications, following may be noted:

- (i) M/s TPL (SUGEN CCPP: 3x382.5MW), vide intimation dated 16.11.2006, was granted 500MW LTOA for transfer of power to Torrent Power (AEC), Torrent Power (SEC), MP and Maharashtra with following transmission system strengthening:
 - o SUGEN – Pirana(PG) 400kV D/c line
 - o LILO of Gandhar – Vapi 400kV S/c line at SUGEN generation switchyard
 - o Installation of 3x315MVA, 400/220kV transformers at SUGEN
 - o 2 nos. 400kV line bays at Pirana(PG) 400/220kV S/s for Double circuit line from SUGEN

- (ii) M/s Torrent Power Grid Ltd. (TPGL) was granted inter-State transmission license on 16.5.2007 vide its Order dated Petition No. 97/2006, to build, own and operate the transmission system for evacuation of power from SUGEN CCPP. On obtaining the inter-State transmission licence, the implementation of the transmission system associated with SUGEN CCPP was undertaken by M/s TPGL.

- (iii) The transmission licence granted to TPL was amended by the Hon'ble Commission vide order dated 1.12.2010 in Petition No. 10/2010 for making LILO of SUGEN – Pirana(PG) 400kV D/c line at Pirana(TPL) so that power from SUGEN CCPP may be directly fed to TPL Ahmedabad, which was one of the beneficiaries of SUGEN CCPP's LTOA. The transmission system was executed in three phases as detailed hereunder:
- Phase 1: 400 kV Loop in Loop out (LILO) at SUGEN bus on one circuit of the Gandhar (Jhanor)-Vapi Line of PGCIL. – **01.03.2009 (COD)**
 - Phase 2: 400 kV D/C line from SUGEN to the point near Gandhar and LILO on one circuit of the Gandhar (Jhanor)-Dehgam Line of PGCIL near Gandhar. – **01.04.2010 (COD)**
 - Phase 3: Extending 400 kV D/C line from LILO point on Jhanor (Gandhar)-Dehgam line to 400 kV Sub-station of PGCIL at Pirana (Kamod) with two number of 400 kV line bays and LILO at 400 kV Pirana Sub-station of Torrent Power Ltd along with opening of LILO point near Gandhar. – **01.04.2011 (COD)**
- (iv) Subsequently, in the 16th Meeting of the WR constituents regarding Connectivity/Open Access Applications held on 09.05.2012, M/s TPL (SUGEN) informed that they have signed PPA of 100MW with the state of MP. Since PPA for balance power was yet to be signed, M/s TPL(SUGEN) requested to reduce the quantum of LTOA from 500MW to 300MW. In view of the same, the revised LTA quantum granted to M/s TPL (SUGEN) became **300MW: 100MW(MP) & 200MW (WR(Target))**.
- (v) Subsequently, M/s TPL(SUGEN) relinquished 50MW LTA from MP and the LTA of TPL(SUGEN) stands at **250MW: 50MW(MP) & 200MW (WR(Target)) prior to GNA Regulations, 2022**.

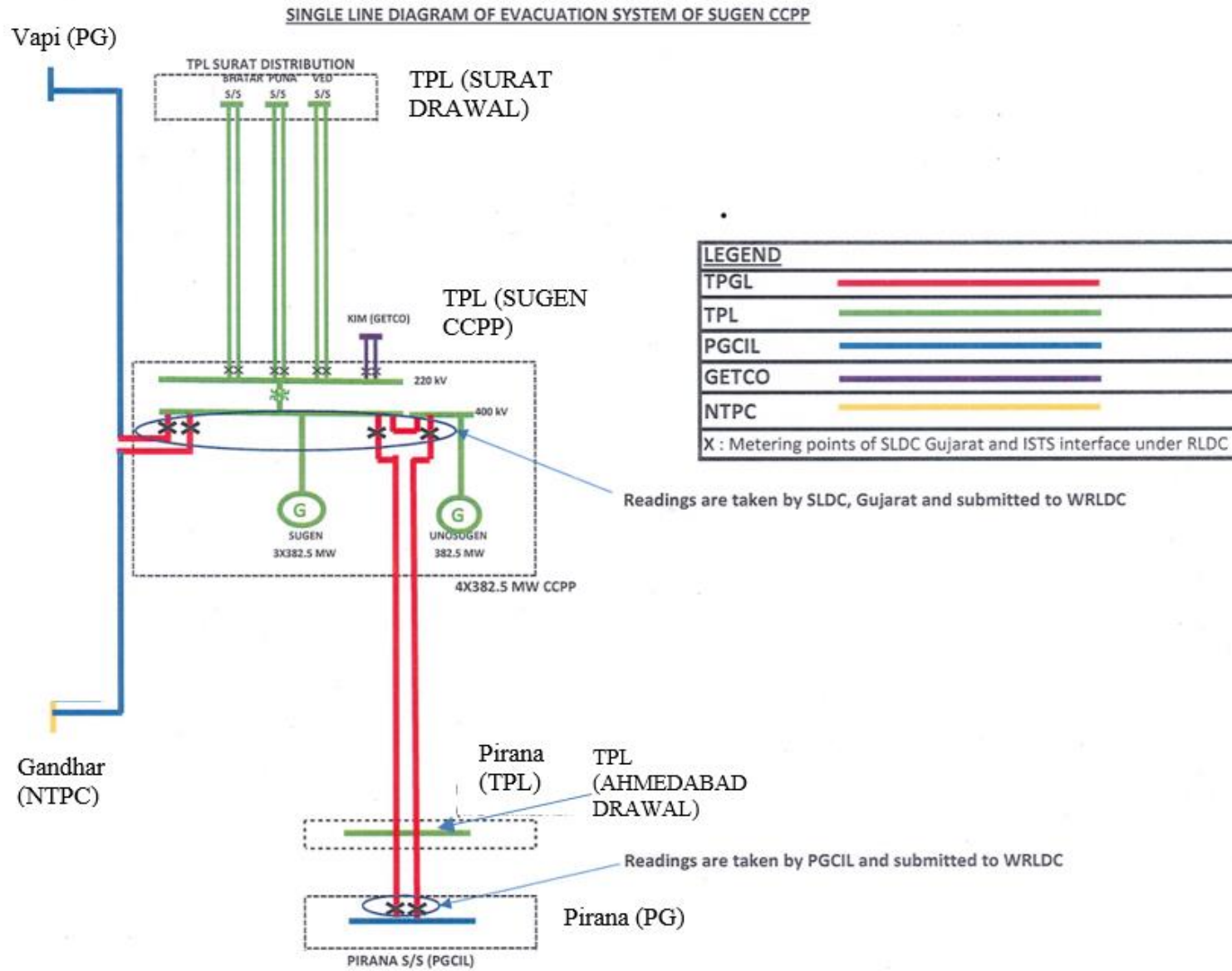

- (vi) Further, LTA has also been granted to Torrent Power Ltd. for 800MW as a distribution licensee (NR(Target): 400MW & WR(Target): 400MW) through Establishment of 400/132kV Nicol S/s through LILO of one ckt of Dehgam – Pirana 400kV D/c line (under scope of distribution licensee) and the same is also operational.
- (vii) M/s TPL has opted for conversion of 382.5MW from its UNOSUGEN CCPP (382.5MW) and 1200MW from its DGEN GPS (3x400MW) to GNA under Regulation 37.6(1) of GNA Regulations, 2022. Further, for TPL's 3x382.5MW Sugan CCPP, 50MW shall be considered as deemed GNA and TPL has opted for conversion of 200MW to GNA under 37.6(2) Regulation and 250MW to GNA under Regulation 37.6(1) of GNA Regulations, 2022.

GETCO stated that under some operating conditions, Sugan 400/220kV ICTs are seen to be non-compliant.

GRID-INDIA stated that the Sugan 3x315MVA, 400/220kV ICTs remained N-1 non-compliant in last quarter for 11% of the time when demand in the area was more than 750MW. The ICTs cater to TPL (~550-600MW) demand as well as demand of Kim S/s of GETCO (~150-200MW). The constraints on the ICTs are more pronounced when Sugan / Unosugan Gas plants are running due to resource adequacy requirement.

CTU enquired that if demand in the area is ~750MW, how GNA of 100MW would suffice for the same.

TPL stated that their total drawl requirement is around 650MW out of which 100MW is proposed to be drawn from ISTS and the balance shall directly be drawn from Sugan generating station (through PPA).

From the above, it was observed that there is requirement of 4th 400/220kV ICT at Sugan for enabling the above additional GNA for TPL (Surat). TPL was requested to share details of space for 4th ICT at Sugan so that their 4th ICT may be planned.

TPL (Ahmedabad) informed that their total load requirement is about 1800MW out of which 800MW is required to be drawn from ISTS and balance is fed through their own plant (360MW) in Ahmedabad as well as 100MW Solar & 400MW Wind, which are connected to Intra-state system.

GRID-INDIA stated that presently there are 3x315MVA, 400/132kV ICTs at Nicol S/s and 4x315MVA, 400/132kV ICTs at Pirana(T) S/s which are expected to be sufficient for drawal of 1000MW power from ISTS under GNA.

After deliberations, it was decided to discuss the matter in a separate meeting. In the mean-time, M/s TPL was requested to share details of space for 4th 400/220kV ICT at Sugan as well as requisite documents w.r.t. license validity modification/extension.

Subsequently, a meeting was held amongst CTU, GRID-INDIA, GETCO & TPL on 11.09.2023 wherein following was discussed:

- TPL explained the following:
 - For Ahmedabad distribution area, they have about 2000MW load (peak) out of which 320MW is fed through Intra-state LTA, 330MW through embedded generation (Sabarmati PP), 450MW additional Intra-state LTA (New-from Mar-24). Further, 45MW deemed GNA has been considered part of Gujarat GNA quantum and now they are applying for 800MW GNA to fulfill their balance power requirement from ISTS. This quantum also includes power to be scheduled from SUGEN CCPP to TPL(Ahmedabad).
 - For Surat distribution area, they have about 700MW load (peak) out of which 200MW is fed through Intra-state LTA, 400MW through SUGEN CCPP (with which they are directly connected at 220kV level) and now they are applying for 100MW GNA to fulfill their balance power requirement from ISTS.
- GRID-INDIA stated that the existing 400/220kV, 3x315MVA Sugan ICTs remain N-1 non-compliant and loading even reaches 3x260MW at times. GETCO also stated that the ICTs are critically loaded in present time-frame.
- CTU stated that in case the ICTs are overloaded presently, the 100MW GNA to TPL(Surat) may only be allowed with ICT augmentation [**1x500MVA, 400/220kV: 4th ICT (along with associated ICT bays)**] at Sugan CCPP by M/s TPL.
- TPL stated that the ICTs are loaded only because the Sugan – Kim 220kV D/c line is also drawing power from them instead of supplying power to TPL as per the Intra-state LTA taken by them. Nevertheless, M/s TPL agreed to install the proposed 4th ICT. However, they requested not to include this ICT as part of system while granting GNA to TPL as this would delay the GNA effectiveness.
- After further deliberations, it was decided that 800MW GNA shall be granted to TPL (Ahmedabad) w.e.f. 01.10.2023 subject to completion of formalities as per CERC GNA Regulations, 2022. With respect to 100MW GNA to TPL (Surat), it was decided that the 4th ICT at Sugan CCPP needs to be implemented immediately and needs to be made part of either the Intra-state LTA taken by TPL(Surat) or else it would be made part of the 100MW GNA grant. TPL and GETCO were requested to discuss the matter bilaterally so that the same may be concluded in the next CMETS-WR meeting.

b) May-23

Sl. No.	Application ID	Name of the Applicant	Submission Date	Region	Nature of applicant	GNA within Region (MW)	GNA outside Region (MW)	Total Quantum (MW) of GNA Required	Start date of GNA	End date of GNA	Conn-BG required
1.	2200000059	Hindustan Zinc Limited	22-05-2023	NR	Bulk consumer seeking to connect to ISTS	250	250	500	31-03-2025	30-03-2050	Conn-BG-1: 50 Lakhs Conn-BG-3: 5 Cr. <i>(considering GNA quantum of 250MW as per deliberations in 20th CMETS-NR meeting on 30.06.2023)</i>

It was informed that M/s HZL has applied for drawl of 500 MW under GNA (250 MW-within region & 250 MW-outside region) at Chittorgarh 400/220 kV ISTS station in Northern region for their Chanderiya Lead Zinc smelter plant from Chittorgarh S/s. The application was discussed in 20th CMETS-NR meeting wherein following was discussed:

- **M/s HZL informed that they intend to draw power from 250 MW RTC project.** Solar part of 250 MW shall come from within the region, i.e., Rajasthan. Wind part (250 MW) shall come from outside the region, i.e. Maharashtra. On overall basis, they require only 250 MW power. However, in the NSW application the pre-defined formula for total GNA has added the power from within & outside region (250MW+250MW) and they require GNA for total 250 MW of power only. They had also informed the same vide their clarification letter dated 08/05/23 that they shall draw total 250 MW from either Rajasthan (Within Region) or Maharashtra (Outside Region)

- **CTUIL informed that at one point of time, the total power intended to be drawn is 250 MW by HZL (Chandheria plant in NR) and for this, constraints may arise outside the region and not inside the region and the total transmission system need to be planned for 250 MW only not 500 MW.** However, application is for 500 MW, which is in contradiction to intended requirement of 250 MW. Regarding this, CTUIL also enquired from GRID INDIA about the how scheduling of this 250 MW shall take place. GRID INDIA informed that power in GNA shall be scheduled in line with the PPA for Solar & Wind power and as per the available margin in the Grid at that time. However, for the capacity exceeding granted GNA quantum, T-GNA may be applied by the applicant, if required.
- M/s HZL submitted they have proposed to be connected through 400 kV S/c line at Chittorgarh substation and further, they shall be connected at 132 kV level at HZL Switchyard at Chandheriya. For the same M/s HZL shall also construct a pooling station at 400/132 kV level. Regarding this, CTUIL highlighted that proposed 400 kV S/c line for 250 MW shall a sub optimal utilization of a 400kV transmission asset. Further with 400kV s/c line there will not be any N-1 reliability for a bulk Consumer. Therefore, it was proposed that M/s HZL may explore feasibility of getting connected at Neemuch substation at 220 kV level, which is also in proximity. HZL agreed to explore the possibility of Connectivity at Neemuch S/s.
- Further, it was deliberated that while applying for GNA, M/s HZL has proposed the disconnection from STU (RVPNL) after availing GNA under ISTS. For the same, M/s HZL informed that they have submitted the application to STU for grant of NOC for disconnection of 250 MW already granted them. However, the NOC is still awaited from STU. (shall be submitted within 10 days)

Further, M/s HZL vide e-mail dated 16.08.2023 informed that post internal evaluation & discussions, they have decided to avail the option to connect their 250 MW bulk consumer facility at Neemuch PS at 220 kV level and requested to consider the following configuration for the transmission infrastructure to connect HZL plant to Neemuch ISTS PS –

- 220 kV D/C line with carrying capacity of 250 MW in each ckt.
- Establishment of 220/132 kV, 1x315 MVA switching station to connect to HZL (Chittorgarh) which is at 132 kV level.

Regarding STU NOC, HZL stated that the STU NoC would be available in 1-2 weeks and HZL shall submit the same to CTU immediately upon receipt of the same (Expected in 10 to 15 days).

M/s HZL was requested to implement 2x315MVA, 400/132kV ICTs instead of 1x315MVA, 400/132kV proposed by HZL so that the transmission system is N-1 compliant.

M/s HZL stated that they shall revert back in 2 days. Subsequently, M/s HZL vide e-mail dated 01.09.2023 confirmed that they shall install 2x315 MVA, 400/132kV ICTs at Hindustan Zinc Limited end to ensure the N-1 compliance. In view of the above, it was agreed to grant 250MW GNA to M/s HZL with the following transmission system. The intimation shall be issued upon receipt of STU NOC.

1. Dedicated Transmission System for GNA:

- HZL(Chittorgarh) – Neemuch PS 220kV D/c line along with associated line bays at Neemuch PS end* (shall be constructed and maintained by a licensee at the cost of such entity)
- Establishment of 220/132 kV, 2x315 MVA Substation at HZL (Chittorgarh) along with 2 nos. 220kV Line bays at the HZL end for HZL – Neemuch 220kV D/c line (under the scope of HZL)

2. Common Transmission System Augmentation for Connectivity under GNA:

- NIL

c) Jun-23

Sl. No.	Application ID	Name of the Applicant	Submission Date	Region	Nature of applicant	GNA within Region (MW)	GNA outside Region (MW)	Total Quantum (MW) of GNA Required	Start date of GNA	End date of GNA	Conn-BG required
2.	2200000129 (Original Application)	Kutch Copper Limited	24-06-2023	WR	Bulk consumer seeking to connect to ISTS	115.0	0.0	115	01-06-2025	31-05-2050	Conn-BG-1: 50 Lakhs Conn-BG-3: 2.3 Cr.

- Applied for GNA_{RE} : Yes
- Nearest ISTS sub-stations: 765/400kV S/s near Navinal (Mundra) (GIS) (Proposed)
 - Applicant has requested to grant connectivity at Navinal Sub-Station (Proposed), Mundra through the network of MPSEZ Utilities Limited (Distribution License in Mundra region) and has undertaken to pay the wheeling charges as determined by Hon'ble GERC from time to time to MPSEZ Utilities Limited (MUL) for utilizing its network to get connected to ISTS system.

It was informed that GNA is proposed to be granted to M/s KCL with following system, which requires certain clarifications from M/s KCL/MUL:

1. Dedicated Transmission System for GNA:

- Interconnection of Kutch Copper Limited with MUL
- KCL shall share the Dedicated Transmission System for GNA of MUL at Sl. 2 or Sl. 3 (as per clarification by applicant)

2. Common Transmission System Augmentation for Connectivity under GNA:

- NIL

It was further informed that additional transmission system for enabling GNA from applicants in Navinal / Mundra area to be constructed and maintained by a licensee at the cost of entities in Mundra area is mentioned below the table.

Representative of M/s KCL stated that KCL is a bulk consumer entity within the distribution area of MUL and would be connected to MUL's 400/220kV S/s at 220 kV voltage level (through 220kV D/c line).

KCL was requested to share the schematic of proposed interconnection.

Details of deliberations w.r.t. additional transmission system for GNA are given below the table.

Sl. No.	Application ID	Name of the Applicant	Submission Date	Region	Nature of applicant	GNA within Region (MW)	GNA outside Region (MW)	Total Quantum (MW) of GNA Required	Start date of GNA	End date of GNA	Conn-BG required
3.	2200000122 (Revised Application)	MPSEZ Utilities Limited	28-06-2023	WR	Distribution licensee seeking to connect to ISTS	495.0	0.0	495	01-04-2029	31-03-2054	Conn-BG-1: 50 Lakhs Conn-BG-3: 9.9 Cr.

- Applied for GNA_{RE} : No
- Nearest ISTS sub-stations: 765/400kV S/s near Navinal (Mundra) (GIS) (Proposed)
 - Distribution license submitted alongwith with the application is in the name of MPSEZ UTILITIES PRIVATE LIMITED whereas applicant is MPSEZ UTILITIES LIMITED. However, applicant vide email dated 04.06.2023 has submitted Certificate of Incorporation regarding change of name of MPSEZ UTILITIES PRIVATE LIMITED to MPSEZ UTILITIES LIMITED w.e.f. 16.06.2020.

It was informed that GNA is proposed to be granted to M/s MUL with following system:

1. Dedicated Transmission System for GNA:

- MUL – Navinal (Mundra) (GIS) 400 kV D/c (Twin HTLS - Quad Moose equivalent) line along with associated line bays Navinal end* (~1-2 km.) (shall be constructed and maintained by a licensee at the cost of such entity)@
- 2 nos. 400kV Line bays at the Dist. Licensee end shall be under the scope of MUL

@Bay(s) required for completion of diameter (GIS) in one-and-half breaker scheme shall also be implemented by the licensee

2. Common Transmission System Augmentation for Connectivity under GNA:

- NIL

Date from which GNA is proposed to be granted: 01.04.2029

Further, additional transmission system for enabling GNA from applicants in Navinal / Mundra area to be constructed and maintained by a licensee at the cost of entities in Mundra area is mentioned below the table.

Details of deliberations w.r.t. additional transmission system for GNA are given below the table.

Sl. No.	Application ID	Name of the Applicant	Submission Date	Region	Nature of applicant	GNA within Region (MW)	GNA outside Region (MW)	Total Quantum (MW) of GNA Required	Start date of GNA	End date of GNA	Conn-BG required
4.	2200000064 (Revised Application)	MPSEZ Utilities Limited	28-06-2023	WR	Distribution licensee seeking to connect to ISTS	642.0	658.0	1300	01-06-2025	31-05-2050	Conn-BG-1: 50 Lakhs Conn-BG-3: 26 Cr.

- Applied for GNA_{RE} : No
- Nearest ISTS sub-stations: 765/400kV S/s near Navinal (Mundra) (GIS) (Proposed)
 - Distribution license submitted alongwith with the application is in the name of MPSEZ UTILITIES PRIVATE LIMITED whereas applicant is MPSEZ UTILITIES LIMITED. However, applicant vide email dated 04.06.2023 has submitted Certificate of Incorporation regarding change of name of MPSEZ UTILITIES PRIVATE LIMITED to MPSEZ UTILITIES LIMITED w.e.f. 16.06.2020.

1. Dedicated Transmission System for GNA:

- MUL – Navinal (Mundra) (GIS) 400 kV D/c (Twin HTLS - Quad Moose equivalent) line along with associated line bays Navinal end* (~1-2 km.) (shall be constructed and maintained by a licensee at the cost of such entity) @
- 2 nos. 400kV Line bays at the Dist. Licensee end shall be under the scope of MUL

@Bay(s) required for completion of diameter (GIS) in one-and-half breaker scheme shall also be implemented by the licensee

2. Common Transmission System Augmentation for Connectivity under GNA:

- NIL

Date from which GNA is proposed to be granted: 01.06.2025

Further, additional transmission system for enabling GNA from applicants in Navinal / Mundra area to be constructed and maintained by a licensee at the cost of entities in Mundra area is mentioned below the table.

Details of deliberations w.r.t. additional transmission system for GNA are given below the table.

Sl. No.	Application ID	Name of the Applicant	Submission Date	Region	Nature of applicant	GNA within Region (MW)	GNA outside Region (MW)	Total Quantum (MW) of GNA Required	Start date of GNA	End date of GNA	Conn-BG required
5.	2200000124 (Revised Application)	Mundra Petrochem Limited (MPL)	28-06-2023	WR	Bulk consumer seeking to connect to ISTS	1140.0	0.0	1140	01-06-2025	31-05-2050	Conn-BG-1: 50 Lakhs Conn-BG-3: 22.8 Cr.

- Applied for GNA_{RE} : Yes
- Nearest ISTS sub-stations: 765/400kV S/s near Navinal (Mundra) (GIS) (Proposed)
 - Applicant has requested to grant connectivity to MPL at Navinal Sub-Station (Proposed), Mundra through the network of MPSEZ Utilities Limited (Distribution License in Mundra region) and has undertaken to pay the wheeling charges as determined by Hon'ble GERC from time to time to MPSEZ Utilities Limited (MUL) for utilizing its network to get connected to ISTS system.

It was informed that GNA is proposed to be granted to M/s MPL with following system, which requires certain clarifications from M/s MPL/MUL:

1. Dedicated Transmission System for GNA:

- Interconnection of MPL with MUL
- MPL shall share the Dedicated Transmission System for GNA of MUL at Sl. 2 / Sl. 3 (as per clarification by applicant)

2. Common Transmission System Augmentation for Connectivity under GNA:

- NIL

Further, additional transmission system for enabling GNA from applicants in Navinal / Mundra area to be constructed and maintained by a licensee at the cost of entities in Mundra area is mentioned below the table.

Representative of M/s MPL stated that MPL is a bulk consumer entity within the distribution area of MUL and would be connected to MUL's 400/220kV S/s at 400 kV voltage level (through 400kV D/c line).

MPL was requested to share the schematic of proposed interconnection.

Details of deliberations w.r.t. additional transmission system for GNA are given below the table.

It was informed that the necessary augmentation for providing connection to the ISTS to above entities (to be constructed and maintained by a licensee at the cost of above entities in Mundra area) is given below:

- Establishment of 4x1500 MVA, 765/400 kV Navinal (Mundra) S/s (GIS) with 2x330 MVAR, 765 kV & 1x125 MVAR, 420 kV bus reactors
- LILO of Bhuj-II – Lakadia 765 kV D/c line at Navinal (Mundra) (GIS) S/s with associated bays at Navinal (Mundra) (GIS) S/s

- Installation of 1x330 MVar switchable line reactor on each ckt at Navinal end of Lakadia – Navinal 765 kV D/c line (formed after above LILO)

Sufficient space provisions must be kept in Navinal (Mundra) S/s (GIS) to enable drawal of more drawee entities in future as was expressed by MUL in earlier CMETS meetings. Suggested space provisions are given below:

Future provision (space for):

- 765/400 kV ICT along with bays- 2 Nos.
- 765 kV line bays along with switchable line reactors – 4 Nos.
- 765 kV Bus Reactor along with bay: 2 Nos. → 765 kV Sectionalizer: 1 -set
- 400 kV line bays along with switchable line reactors– 6 Nos.
- 400/220 kV ICT along with bays -6 Nos.
- 400 kV Bus Reactor along with bays: 3 Nos.
- 400 kV Sectionalization bay: 1- set
- 220 kV line bays: 10 Nos.
- 220 kV Sectionalization bay: 1 set
- 220 kV BC and TBC: 2 Nos.
- STATCOM (±300 MVAR) along with MSC (2x125 MVar) & MSR (1x125 MVar) and associated bays- 2 Nos.

Representative of MUL stated that since multiple bulk consumer entities have applied for ISTS connectivity in the Mundra area, which does not have any ISTS substation in close vicinity, the above proposed additional transmission system for GNA for providing connection to the ISTS should be implemented under ISTS.

CTU stated that the Regulation 12.5 of the GNA Regulations, 2022 states the following:

“12.5. In case of an entity covered under Regulation 17.1(iii), *the line to connect such an entity to the ISTS and necessary augmentation for providing connection to the ISTS, shall be constructed and maintained by a licensee at the cost of such entity*”

Further, Regulation 22.2 of the Principal Regulations states as under:

“(b-i) Entities covered under clause (iii) of Regulation 17.1 shall furnish Conn-BG1 for Rs 50 lakhs per application and Conn-BG3 for Rs 2 lakh/MW”.

The Bhuj-II – Lakadia 765kV D/c line is the nearest ISTS line from Mundra area. Hence, establishment of 765/400kV GIS S/s in Navinal (Mundra) area through LILO of Bhuj-II – Lakadia 765 kV D/c line has been proposed, which is the minimum augmentation required for providing connection to the entities in Mundra area with the existing ISTS.

Further, in respect of the above, it was informed that as per deliberations in a meeting under the chairmanship of Chairperson(CEA) on 12.07.2023, it was decided that ISTS identified/planned for potential based bulk consumers including consumers producing green hydrogen can be considered as common augmentation provided the potential site of such bulk consumers has been confirmed by the central/state government.

MNRE stated that they have received several proposals for green hydrogen / green ammonia production in Mundra as well as other areas and the same shall be shared with CTU after compilation of all proposals by their Green Hydrogen team.

CTU stated that as on date, no such intimation has been received from Central or State govt. and hence Regulation 12.5 of the GNA Regulations, 2022 would be followed and the necessary augmentation for providing connection to the ISTS to above entities shall be constructed and maintained by a licensee at the cost of such entities. However, M/s MUL/MPL/KCL are at liberty to approach the Hon’ble CERC seeking further clarity w.r.t. the planning of augmentation works for the multiple entities under clause (iii) of Regulation 17.1 in Mundra area.

GETCO stated that they are in agreement with the above proposal that the entire augmentation work to connect the bulk consumer entities to ISTS shall be borne by the entities themselves as this would not provide any benefit to the STU(s).

The entities were requested to share schematic diagram of their proposed interconnections with each other so that aspects such as Scheduling & metering aspects for drawal of power from above entities can also be deliberated with GRID-INDIA (as GNA has been sought by MUL & GNA-RE by MPL/KCL, which would need to be accounted for separately). After further deliberations, it was decided to take up the matter again for deliberations in the next meeting.

The same was subsequently received from MUL vide letter dated 01.09.2023 as reproduced below:

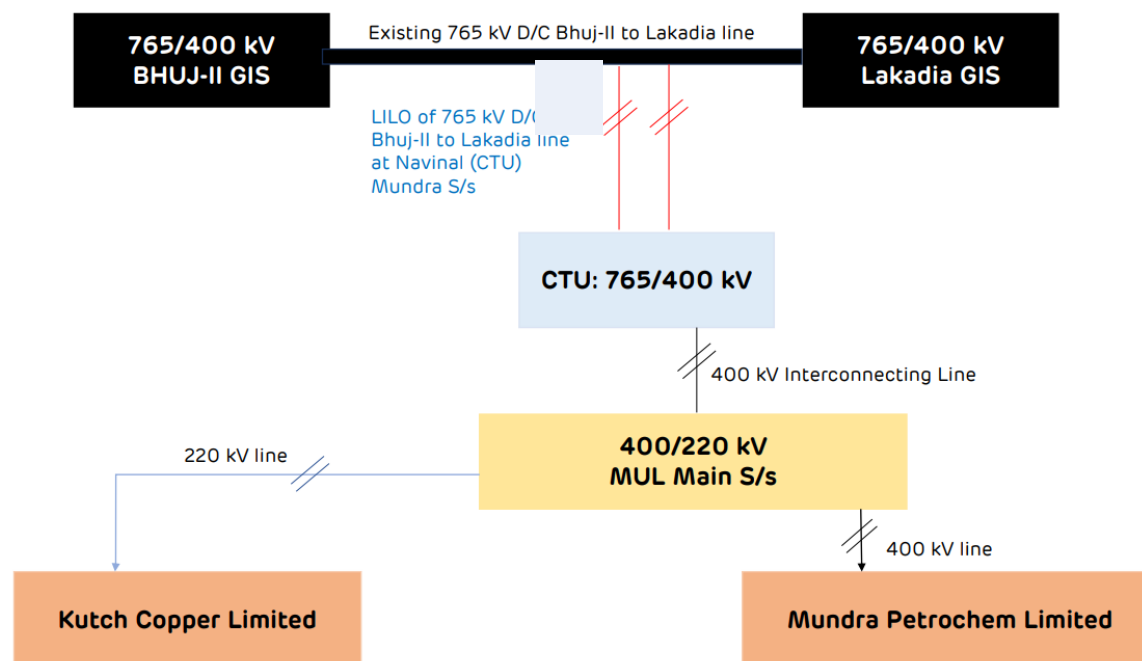

III. Application for addition of Generation Capacity including ESS within the quantum of connectivity granted under Regulation 5.2:

Sl. No.	Application ID	Name of the Applicant	Nature of Applicant	Submission Date	Region	Project Location	Connectivity location	Planned additional capacity (MW)	Date from which additional generation capacity will be added	Remarks
1.	2200000148 (Revised Application)	Veh Jayin Renewables Private Limited	(i) Generating station(s), including REGS(s), without ESS	12-07-2023	WR	Dhar, Madhya Pradesh	400/220kV Rajgarh S/s	45	28-08-2024	-

Sl. No.	Application ID	Name of the Applicant	Nature of Applicant	Submission Date	Region	Project Location	Connectivity location	Planned additional capacity (MW)	Date from which additional generation capacity will be added	Remarks
										<ul style="list-style-type: none"> • Energy Source: Solar • Application number of already granted Connectivity: 0231300002 • Cumulative Connectivity granted: 151.8 MW • Owner of additional generation capacity: Self <p>It was informed that the applicant has applied under Regulation 5.2 of CERC GNA Regulations, 2022 for addition of 45 MW solar generation capacity within the quantum of connectivity granted (151.8MW as wind project).</p> <p>After deliberations, the above enhancement was agreed and M/s VJRPL was informed that the net injection at any point of time shall not exceed the quantum of total Connectivity granted to the existing Connectivity grantee i.e. Veh Jayin Renewables Private Limited (St-II appl. No. 231300002) for 151.8MW. Further, Veh Jayin Renewables Private Limited (St-II appl. No. 231300002) shall be responsible for compliance with the Grid Code and other regulations of the Central Commission for above additional generation capacity as 'Lead generator' in terms of clause (y)(ii) of Regulation 2.1.</p> <p>Applicant shall submit the technical connection data i.r.o. above 45 MW for checking necessary compliances. In this respect, applicant was requested to furnish the details at the earliest so as to provide sufficient time for ensuring necessary compliances.</p>

All applicants under Sl. I, II & III were also requested to note the following:

- It may be noted that as per 22.2(d) of GNA Regulations, "Entities covered under Regulation 4.1 and clause (iii) of Regulation 17.1 of these regulations shall furnish one-time GNA charge for Rs. One lakh per MW for the quantum of GNA one month prior to the start date of GNA. In case, such charges are not furnished by the entity within the specified timeline, the same shall be recovered by encashment of ConnBG1, ConnBG2 and Conn-BG3 as required. The proceeds of such onetime GNA charge shall be used for reducing Monthly Transmission Charges under the Sharing Regulations:
- Provided that the entities covered under Regulation 17.1(iii) shall pay monthly transmission charges for its GNA in addition to one-time GNA charge in accordance with the Sharing Regulations."
- Further, as per 40.2 of GNA regulations, one-time GNA charges shall not be payable for the capacity which has been declared commercial operation as on date of coming into effect of these Regulations.

Applicants noted the above.

IV. Application for grant of additional GNA by STUs

The following was informed w.r.t. applications for grant of additional GNA by STUs:

- Regulation 19.1 of the GNA Regulations state as follows:

“Within 3 months of coming into force of these regulations, STU may, on behalf of intra-State entities including distribution licensees, apply for additional GNA over and above the GNA deemed to have been granted under clauses (a) to (e) of Regulation 18.1 of these regulations (with entity-wise segregation) indicating GNA within the region and from outside the region.”

- Further, Regulation 22.1(a) of the GNA Regulations state as follows:

“The Nodal Agency shall process all applications received under Regulation 19.1 of these regulations together, within two months from last day of receipt of applications and grant additional GNA to STU based on available transmission capacity, or on pro-rata basis, if necessary. GNA once granted shall remain valid until relinquished.”

- CERC vide order dated 03.08.2023 has notified that the CERC (Indian Electricity Grid Code) Regulations, 2023, shall come into force with effect from 01.10.2023. Scheduling and Despatch of electricity with effect from **01.10.2023** shall be based on quantum of GNA, GNARE, T-GNA and T-GNARE of each of the Designated ISTS Customers (DICs) and other users of the grid in accordance with the provisions of the Central Electricity Regulatory Commission (Indian Electricity Grid Code) Regulations, 2023.
- In this respect, additional GNA has been applied by CSPTCL vide letter dated 02.06.2023 & GETCO vide letter dated 05.07.2023 as per details given below:

Sl.	State (STU)	Deemed GNA (MW)			Addl. GNA Requested (MW)			Total GNA Required (MW)			Peak Demand (MW)	Available Tr. Capability (MW)*
		Within region	Outside region	Total	Within region	Outside region	Total	Within region	Outside region	Total		
1	Gujarat (GETCO)	5458	976	6434	3439.3	832	4271.3	8897.3	1808	10705.3	22225	11850
										<ul style="list-style-type: none"> • GUVNL: 10500 MW • Torrent Dahej: 50MW • Indian Railway Gujarat: 141.3MW • Heavy Water Board: 14MW 		
2	Chhattisgarh (CSPTCL)	1902	247	2149	996.78	-	996.78	2898.78	247	3145.78 (CSPDCL)	5869	2540

**As per the minimum values for TTC/ATC figures published by NLDC for the month of Oct-23*

With respect to GETCO, it was observed that sufficient margins exist for grant of additional GNA of 4271.3MW to Gujarat w.e.f. 01.10.2023. **Accordingly, it was agreed to grant 4271.3MW (3439.3MW: From within region & 832MW from outside region) additional GNA to GETCO w.e.f. 01.10.2023.**

With respect to CSPTCL, it was observed that sufficient margins for drawal of power from ISTS do not exist beyond 2540MW.

In this respect, CSPTCL stated that Bhatapara ICT is ready for commissioning, NSPCL reconfiguration has already been carried out and the LTS at Raigarh has also been planned and is in advanced stage of execution. The 3rd ICT at Raigarh shall also be commissioned prior to peak demand season of Chhattisgarh in Feb-24. Further, drawal of more than 3100MW by Chhattisgarh is also being allowed by GRID-INDIA. Hence, the proposed total GNA of 3145.78MW may be granted to them so that no issues are encountered in peak demand season of Chhattisgarh (around Feb- 24).

GRID-INDIA stated that although the drawal was allowed upto 3100MW, several N-1 constraints are still peristing in Chhattisgarh (when demand is ~5800MW), which cannot be ignored while deciding on grant of GNA to Chhattisgarh, viz:

- NSPCL 400/220kV ICTs N-1 non-compliance
- Raigarh 400/220kV ICTs N-1 non-compliance
- Bhatapara 400/220kV ICTs N-1 non-compliance
- Raipur 400/220kV ICTs N-1 non-compliance
- Bhilai 400/220kV ICTs N-1 non-compliance

CSPTCL stated that the GNA value may be finalized based on revision in ATC value which shall be carried out by GRID-INDIA based on inputs which shall be provided by CSPTCL.

GRID INDIA informed that LTS schemes are required to be implemented at some ICTs and Chhattisgarh is also required to update details of 220kV network. Based on the same, ATC values shall be revised by them.

After further deliberations, it was decided to grant **391MW (From within region) additional GNA to CSPTCL w.e.f. 01.10.2023**. Further, any additional GNA (beyond 391MW) shall be granted based on feedback from CSPTCL / GRID-INDIA regarding revised ATC values w.e.f. 01.10.2023.

Meeting ended with a vote of thanks.

--X-----X—

Flag-I: List of Participants

Sl. No.	Name	Designation	Organization	Email ID
1	Jasbir Singh	ED	CTUIL	jasbir@powergrid.in
2	Partha Sarathi Das	Sr.GM	CTUIL	psdas@powergrid.in
3	Kamal Kumar Jain	GM	CTUIL	kkjain@powergrid.in
4	Koushik Goswami	DGM	CTUIL	koushikgoswami@powergrid.in
5	Bhaskar Lakshman Rao Wagh	Ch.Manager	CTUIL	bhaskarwagh@powergrid.in
6	Chinmay Sharma	Ch.Manager	CTUIL	chinmays@powergrid.in
7	Pratyush Singh	Ch.Manager	CTUIL	pratyush.singh@powergrid.in
8	Shashank Shekhar	Manager	CTUIL	shashankshekhar@powergrid.in
9	Narendra Sathvik Ranganath	Manager	CTUIL	rnsathvik@powergrid.in
10	Mahendranath Malla	Manager	CTUIL	mahendranth.malla@powergrid.in
11	Treepati Sonkatar	Manager	CTUIL	treepati@powergrid.in
12	Prashanth Kumar Gade	Dy. Manager	CTUIL	prashanthgade@powergrid.in
13	Sri Ajay Kumar	Asst. Manager	CTUIL	sriajaykumar@powergrid.in
14	Sricharan Rangudu	Engineer	CTUIL	sricharan@powergrid.in
15	M Venkateswara Rao	Manager	WRLDC, Grid-India	venkyminnakuri@grid-india.in
16	Rohit Thakwani	Scientist, Transmisison	MNRE	rohit.mnre@gov.in
17	R K Shukla	ED(PC&RA)	CSPTCL	-
18	N. S. Bharel	CEDE	SECR	cedesecr@gmail.com
19	P K Chauhan	SSE TRD HQ	SECR	pkchauhan2205@gmail.com
20	Ateesh Samant	COO	ABEnergia Renewables Pvt Ltd	ateesh.samant@aberenewables.com
21	Jagadish Gurav	Sr VP	ABEnergia Renewables Pvt Ltd	jagadish.gurav@aberenewables.com
22	Amit Kumar Singh	Associate Manager	Adani Power Limited	amitkumar.singh3@adani.com
23	Chintan Mankad	Senior Manager	Adani Power Limited	chintan.mankad@adani.com
24	Hitesh Modi	General Manager	Adani Power Limited	hitesh.modi@adani.com
25	Jayadeb Nanda	Chief Operations Officer	Adani Power Limited	jayadeb.nanda@adani.com
26	Abhishek Tyagi		Adani	abhishek.tyagi@adani.com

Sl. No.	Name	Designation	Organization	Email ID
27	Ankit Rabadia		Adani	ankitv.rabadia@adani.com
28	Avinash Anurag		Adani	avinash.anurag@adani.com
29	Gunjan Thakre		Adani	gunjan.thakre@adani.com
30	Hemant Kumar Mallick		Adani	hemant.mallick@adani.com
31	Kumar Gaurav		Adani	kumar.gaurav2@adani.com
32	Manish Kumar		Adani	manish.kumar3@adani.com
33	Mayursinh Gohil		Adani	mayursinhd.gohil@adani.com
34	Praveen Tamak		Adani	praveen.tamak@adani.com
35	Sameer Ganju		Adani	sameer.ganju@adani.com
36	Shanmughan K		Adani	shanmughan.k1@adani.com
37	Vikas Rana		Adani	vikas.rana1@adani.com
38	Tejas Shinde		Anupavan Renewables Pvt. Ltd.	tejas.shinde@egreenpower.co
39	Angshuman Rudra	General Manager	Avaada Energy Pvt Ltd	angshuman.rudra@avaada.com
40	Ashish Shukla	Sr.G.M	Avaada Energy Pvt Ltd	ashish.shukla@avaada.com
41	Altaf Tamboli	Senior Development Manager	Avaada Energy Pvt Ltd	
42	Vikash Agrawal		BALCO	vikash.agrawal@vedanta.co.in
43	Vishnu Khandelwal		BALCO	vishnu.khandelwal@vedanta.co.in
44	Livingston Emmanuel	Head of Development & Commercial	Blue Leaf Energy	livingston.emmanuel@blueleafenergy.com
45	Nitika Mittal		Blue Leaf Energy	nitika.mittal@blueleafenergy.com
46	Shakko Mukherjee		Blue Leaf Energy	shakko.mukherjee@blueleafenergy.com
47	Snigdha Kala		Blue Leaf Energy	snigdha.kala@blueleafenergy.com
48	Surendra Shekhawat		Blue Leaf Energy	surendra.shekhawat@blueleafenergy.com
49	Mukesk Kumar	Manager	D B Power Limited	sales@dbpower.in
50	Abhishek Agarwal		feplglobal.com	abhishek.agarwal@feplglobal.com
51	Vasundhara Sen		feplglobal.com	vasundhara.sen@feplglobal.com

Sl. No.	Name	Designation	Organization	Email ID
52	A K Vaishnav		GIPCL	akvaishnav@gipcl.com
53	H L Parekh		GIPCL	hlparekh@gipcl.com
54	K R Ghataliya		GIPCL	krghataliya@gipcl.com
55	Anish Pasrija	GM	Greenko MP01 IREP Pvt Ltd	anish.p@greenkogroup.com
56	Pushpinder Hira	Manager	Greenko MP01 IREP Pvt Ltd	pushpinder.h@greenkogroup.com
57	Ranjan Kumar	Sr Manager	Kutch Copper Limited	ranjan.kumar3@adani.com
58	Manoj Tanuk	Asso Vice President	Mahan Energen Limited	manoj.taunk@adani.com
59	Mehul Rupera	Whole Time Director	MPSEZ Utilities Limited	mehul.rupera@adani.com
60	Mohit Srivastava	Manager	Mundra Petrochem Limited	mohit.srivastava@adani.com
61	Animesh Manna	Dy. General Manager	NTPC renewable energy limited	amanna@ntpc.co.in
62	Mohit Jain	Manager	ReNew Private Limited	mohit.jain@renew.com
63	Hemalatha Polaki		ReNew Private Limited	hemalatha.polaki@renew.com
64	Aakanksha Bhisikar	Business Development	Serentica Renewables India Pvt. Ltd	aakanksha.bhisikar@serenticaglobal.com
65	Arzaan Dordi	Chief Manager	Serentica Renewables India Pvt. Ltd	arzaan.dordi1@serenticaglobal.com
66	Sumit Joge	GM - BD and Regulatory	Sprng Akshaya Urja Pvt Ltd	sumitjoge@sprngenergy.com
67	Zafar Khan	GM - Project (Wind)	Sprng Akshaya Urja Pvt Ltd	zafarkhan@sprngenergy.com
68	Biswajit Das	Project Dev Compliance Mgr	Sprng Energy	biswajitdas@sprngenergy.com
69	Poorva Pitke	Sr. Manager - Regulatory & Buisness Development	Sprng Energy	poorvapitke@sprngenergy.com
70	Sharmilaa S	AGM - BD	Sprng Energy	sharmilaas@sprngenergy.com
71	Vivek Mate	Group Head Special projects	Tata Power	vivekmate@tatapower.com
72	Abhijeet Patil	Head Special Projects	Tata Power	abhijeetpatil@tatapower.com
73	Narayan Santosh		Tata Power	narayans@tatapower.com
74	Gavadhakatla S V		Tata Power	sivanarayana@tatapower.com
75	K A Vishwanath	General Manager - Project Development	TEQ Green Power XI Pvt Ltd	pe@o2power.in

Sl. No.	Name	Designation	Organization	Email ID
76	Tushar Garg	Deputy Manager - Project Development	TEQ Green Power XI Pvt Ltd	tushar.garg@o2power.in
77	Bhavik Shah	Power Mgmt & Scheduling	Torrent Power	bhavikshah@torrentpower.com
78	Ronak Naik	Power Marketing	Torrent Power	ronaknaik@torrentpower.com
79	Chandramouli Reddy		VEH ARPL & VEH WEPL	cmreddy@vibrantenergy.in
80	Pritesh Lodha		VEH ARPL & VEH WEPL	plodha@vibrantenergy.in