

2029-30

ISTS Rolling Plan

Interim report

CTUIL

September 2024

ISTS ROLLING PLAN 2029-30
INTER-STATE TRANSMISSION SYSTEM (ISTS)
(INTERIM REPORT)

SEPTEMBER 2024

Page intentionally left blank

Table of Contents

EXECUTIVE SUMMARY	1
CHAPTER 1: BACKGROUND AND OBJECTIVE	5
CHAPTER 2: POWER SUPPLY SCENARIO	7
2.1 POWER SUPPLY SCENARIO AS OF AUG'24	7
2.2 ENVISAGED POWER SUPPLY SCENARIO BY 2029-30	8
CHAPTER 3: ALL INDIA	11
3.1 LOAD GENERATION BALANCE.....	12
3.2 ISTS EXPANSION UPTO 2029-30	20
3.3.1 Summary of ISTS network.....	20
3.3.2 Inter-Regional (IR) Capacity	22
CHAPTER 4: NORTHERN REGION.....	23
4.1 POWER SUPPLY SCENARIO AS ON AUG'24.....	23
4.2 ENVISAGED POWER SUPPLY SCENARIO BY 2029-30	24
4.3 LOAD GENERATION BALANCE FOR 2029-30 TIMEFRAME.....	25
4.4 ISTS NETWORK EXPANSION SCHEMES EVOLVED FROM FEB'24/MAR'24 TO JULY'24	25
4.4.1 Rajasthan	27
4.4.2 Punjab.....	54
4.4.3 Jammu & Kashmir	57
CHAPTER 5: WESTERN REGION	63
5.1 POWER SUPPLY SCENARIO AS ON AUG'24.....	63
5.2 ENVISAGED POWER SUPPLY SCENARIO BY 2029-30	64
5.3 LOAD GENERATION BALANCE FOR 2029-30 TIMEFRAME.....	65
5.4 ISTS NETWORK SCHEMES EVOLVED FROM FEB'24/MAR'24 TO JULY'24	65
5.4.1 Gujarat.....	67
5.4.2 Maharashtra	89
5.4.3 Madhya Pradesh.....	91
5.4.4 Chhattisgarh	98
CHAPTER 6: SOUTHERN REGION	103
6.1 POWER SUPPLY SCENARIO AS ON AUG'24.....	103
6.2 ENVISAGED POWER SUPPLY SCENARIO BY 2029-30	104
6.3 LOAD GENERATION BALANCE FOR 2029-30 TIMEFRAME.....	105
6.4 ISTS NETWORK EXPANSION SCHEMES EVOLVED FROM FEB/MAR'24 TO JUL'24	105
6.4.1 Karnataka	107
6.4.2 Andhra Pradesh	111
6.4.3 Tamil Nadu	124
CHAPTER 7: EASTERN REGION	131
7.1 POWER SUPPLY SCENARIO AS ON AUG'24.....	131
7.2 ENVISAGED POWER SUPPLY SCENARIO BY 2029-30	132
7.3 LOAD GENERATION BALANCE FOR 2029-30 TIMEFRAME	133
7.4 ISTS NETWORK EXPANSION SCHEMES EVOLVED FROM FEB'24/MAR'24 TO JULY'24	133
7.4.1 Odisha.....	134

7.4.2 West Bengal	135
7.4.3 Bihar, Odisha & West Bengal.....	137
CHAPTER 8: NORTH EASTERN REGION	141
8.1 POWER SUPPLY SCENARIO AS ON AUG'24.....	141
8.2 ENVISAGED POWER SUPPLY SCENARIO BY 2029-30	141
8.3 LOAD GENERATION BALANCE FOR 2029-30 TIMEFRAME	142
8.4 ISTS NETWORK EXPANSION SCHEMES EVOLVED FROM FEB'24/MAR '24 TO JULY'24	143
8.4.1 Arunachal Pradesh	144
8.4.2 Assam.....	145
8.4.3 Nagaland.....	148
8.4.4 Arunachal Pradesh & Assam	150
CHAPTER 9: CROSS-BORDER INTERCONNECTION	153
9.1 INDIA-BANGLADESH.....	153
9.2 INDIA-BHUTAN	153
9.3 INDIA-MYANMAR.....	154
9.4 INDIA-NEPAL	154
9.5 INDIA-SRI LANKA.....	155
CHAPTER 10: CONCLUSION	157

List of Figures

Figure 2-1: Installed Capacity & Demand trend in GW	7
Figure 2-2: Installed Capacity and Peak Demand as of Aug'24	8
Figure 2-3: Projected Installed Capacity & Peak Demand by FY 2029-30	9
Figure 3-1: India's map showing various generations in different parts of the country	11
Figure 3-2: Summer (June'23) Load Curve	13
Figure 3-3: Monsoon (Aug'23) Load Curve	13
Figure 3-4: Winter (Feb'23) Load Curve	14
Figure 3-5: Demand factors considered for present study	14
Figure 3-6: LGB for Monsoon (Aug'2029)	16
Figure 3-7: LGB for Summer (June'2029)	17
Figure 3-8: LGB for Winter (Feb'2030)	18
Figure 3-9: Growth in IR Capacity (MW)	22
Figure 4-1 : Schematic of 400/220 kV Bassi (PG) S/s	28
Figure 4-2: Schematic of 400/220 kV Bhiwadi (PG) S/s	30
Figure 4-3: Schematic of 400/220 kV Bikaner-II PS	32
Figure 4-4: Schematic of 765/400/220 kV Fatehgarh-IV PS	34
Figure 4-5: Schematic of 765/400/220 kV Barmer-I PS	35
Figure 4-6: Transmission system for Rajasthan REZ Ph-IV (Part-4 :3.5GW) [Fatehgarh/Barmer complex]	39
Figure 4-7: Transmission system for evacuation of power from Rajasthan REZ Ph-V (Part-1: 4 GW) [Sirohi/Nagaur] Complex	50
Figure 5-1: Schematics of KPS1 (a), KPS2 (b) & KPS3 (c) substations with the ICT augmentations	70
Figure 5-2: Schematic of Lakadia S/s representing augmentation of transformation capacity	74
Figure 5-3: Schematic of Vadodara S/s representing augmentation of transformation capacity	75
Figure 5-4: Schematic of Banaskantha PS representing augmentation of transformation capacity. ...	76
Figure 5-5: Representation of Tr. system to provide redundant power supply to Dholera area of Gujarat	78
Figure 5-6: Schematic representation of Tr. system for evacuation of RE power from Raghnesda area of Gujarat – 3 GW under Phase-I	81
Figure 5-7: Schematic representation of Ts. system for evacuation of Green Hydrogen/Ammonia potential in Kandla area of Gujarat (Phase-I: 3 GW)	83
Figure 5-8: Schematic representation of Tr. system for supply of power to Green Hydrogen/Green Ammonia manufacturing potential in Mundra area of Gujarat under Phase-I	85
Figure 5-55-9: Schematic representation of Tr. System for Offshore Wind Zone Phase-1	89
Figure 5-55-10: Schematic of Tr. Scheme for interconnection of PSPs in Maharashtra	91
Figure 5-55-11: Schematic of Network Expansion Scheme in Vindhyachal Complex	92
Figure 5-55-12: Schematic of Neemuch S/s representing the Tr. System for enabling RE interconnection	93
Figure 5-55-13: Schematic for Tr. system for Evacuation of Power from RE Projects in Madhya Pradesh	94
Figure 5-55-14: Transmission scheme for evacuation of power from 1200MW Mahan TPS & 1600MW Mahan extension plant	98
Figure 7-1 SLD of Pandiabili for ERES-42	135
Figure 7-2: Schematic ERGS-II	136
Figure 7-3: Schematic of ERES-43	138
Figure 8-1: Schematic NERES-XXIII	144

Figure 8-2: Schmeatic NERES-XXVI 146

Figure 8-3: Schematic NERES-XXVIII 148

Figure 8-4: Schematic NERES-XXVII..... 149

Figure 8-5: Schematic NERES-XXIX (Biswanath Chariali Reactor) 151

Figure 8-6: Schematic NERES-XXIX (Namsai ICT)..... 152

Figure 9-1 Cross-Border interconnections 156

List of Tables

Table 2-1: Installed Capacity and Peak Demand in GW as of Aug'24	8
Table 2-2: Projected Installed Capacity & Peak Demand by FY 2029-30	9
Table 2-3: Peak demand & Generation IC in Aug'24 and 2029-30	9
Table 3-1: Regional Surplus/Deficit summary in MW	19
Table 3-2: Under Construction Transmission Line (in ckm)	20
Table 3-3: Under Construction Transformation Capacity (in MVA)	20
Table 3-4: Broad estimated cost (in ₹ Cr.) (Under Construction).....	20
Table 3-5: Under planning/bidding/approval Transmission Lines (in ckm).....	21
Table 3-6: Under planning/bidding/approval Transformation Capacity (in MVA).....	21
Table 3-7: Broad estimated cost (in ₹ Cr.) (under planning/bidding/approval).....	21
Table 3-8 : Transmission system evolved to cater RE integration and GH/GA (in MW)	22
Table 4-1: NR Installed Capacity and Peak Demand as on Aug'24	23
Table 4-2: NR Installed Capacity and peak demand (2029-30).....	24
Table 4-3: Increase in Peak Demand of Various States of NR	24
Table 4-4: Northern Region Generation Dispatch and Demand Factors	25
Table 5-1: WR Installed Capacity and Demand met as on Aug'24	63
Table 5-2: WR Installed Capacity and Peak Demand (2029-30).....	64
Table 5-3: Increase in Peak Demand of Various States of WR	64
Table 5-4: Western Region Generation Dispatch and Demand Factors	65
Table 5-5: Details of the schemes evolved in WR.....	66
Table 6-1: SR Installed Capacity and Peak Demand as on Aug'24.....	103
Table 6-2: SR Installed Capacity and peak demand (2029-30)	104
Table 6-3: Increase in Peak Demand of Various States of SR.....	104
Table 6-4: Southern Region Generation Dispatch and Demand Factors	105
Table 6-5: Details of the schemes evolved in SR	105
Table 7-1 ER Installed Capacity and Peak Demand as on Aug'24.....	131
Table 7-2: ER Installed Capacity and Peak Demand (2029-30).....	132
Table 7-3: Increase in Peak Demand of Various States of ER	132
Table 7-4: Eastern Region Generation Dispatch and Demand Factors.....	133
Table 7-5: Approved Transmission Schemes in this Rolling Plan	134
Table 8-1: NER Installed Capacity and Peak Demand as on Aug'24.....	141
Table 8-2: NER Installed Capacity and peak demand (2029-30)	142
Table 8-3: Increase in Peak Demand of Various States of NER.....	142
Table 8-4: North Eastern Region Generation Dispatch and Demand Factors	143
Table 8-5: Approved Transmission Schemes in this Rolling Plan	143
Table 9-1: Cross-border power transfer capacity by 2029-30	155

Page intentionally left blank

Executive Summary

Today, India is on the path of high economic growth and is aiming to be a 5 trillion USD economy by 2030. Electricity sector is playing a very vital role in this economic development by acting as a secure and reliable source of energy. One of the emerging utilisations of electricity today is in the transportation sector with Central and State Governments promoting faster adoption of Electric Vehicles (EVs), to reduce emission of greenhouse gases. To meet the growing energy demand in sustainable and eco-friendly manner, India is going through a phase of energy transition at rapid pace with greater focus on development of new Renewable Energy (RE) resources. In this direction, at the COP26 climate conference in Glasgow, India has committed to achieve non-fossil energy capacity of 500GW by 2030 and to meet 50 per cent of its energy requirement through RE by 2030. Further, India has also set target of being a net zero emitter by 2070.

There is a continuous strong growth in demand for electricity in the country. The emerging utilisations of electricity today is observed in the transportation sector to reduce emission of greenhouse gases. Govt. of India came up with Green Hydrogen Policy in Feb 2022 and National Green Hydrogen Mission in January 2023, and it is expected that there is going to be power requirement in the National Grid to the tune of 125 GW from industries producing Green Hydrogen and Green Ammonia using power from Renewable Energy (RE) resources. ISTS planning has been initiated in this direction to provide requisite power to such industries from large RE complexes.

To achieve the energy transition goals and facilitate large scale integration of RE, Central Electricity Authority (CEA) published a Report titled “Transmission System for Integration of over 500GW RE Capacity by 2030” in Dec 2022 inter alia including details of the transmission requirement for RE integration till 2030, energy storage requirement in the grid, new HVDCs requirement etc. Also keeping pace with latest international best practices in transmission planning, CEA has updated and came up with “Manual on Transmission Planning Criteria, 2023”

The huge quantum of RE generations being integrated in the National Grid to meet the energy transition goals, needs to be transferred reliably and securely to all the major load centres of the country. This necessitates continuous development of a robust National Grid comprising of high capacity AC and HVDC systems along with state-of-the-art FACTS devices for controlling power system parameters. Electrical Energy storage (BESS/PHS) would play a significant role towards meeting energy transition goals. India’s path and ways of RE integration to its National Grid can act as blue print for other countries for development of new age electricity grid. There is also a thrust on development and integration of Energy Storage devices in form of batteries, pumped hydro etc. in the National Grid, for providing balancing power during low or no RE period and also increasing utilisation of transmission system associated with RE projects.

Transmission system plays a very crucial role of facilitating integration of generation resources and demand centres to the National Grid, and therefore should be planned and developed

adequately so as to enable seamless integration of generation projects and also facilitate availability of reliable, secure, and affordable power to all the consumers.

In this direction, and as per Electricity (Transmission System Planning, Development and Recovery of Inter-State Transmission Charges) Rules, 2021, notified by Ministry of Power, Govt. of India, CTU has been publishing the ISTS Rolling Plan Reports on half-yearly basis (Interim Report in Sept and Final Report in March of every financial year) with last one being published on 31st Mar 2024. This ISTS Rolling Plan Report has been prepared to assess transmission system requirement in ISTS for 2029-30 time-frame taking due consideration of “Transmission System for Integration of over 500MW RE Capacity by 2030” report.

Chapter-1 gives Background and Objectives of the ISTS Rolling Plan Report.

In **Chapter-2**, installed capacity & peak demand as on Aug’24 and projected installed capacity & demand by FY 2029-30 have been presented. All India installed capacity & peak demand are expected to increase from 450GW (including about 152.6GW RE + 47GW Hydro) & 250GW respectively as on Aug’24 to about 776 GW (including about 396GW RE + 63GW Hydro+35GW ESS) & 335GW respectively by FY 2029-30.

In order to integrate the envisaged generation capacity, predominantly RE, and to meet the projected demand, comprehensive studies need to be performed on the National Grid on All India and Regional basis for planning and development of Inter-State Transmission System (ISTS). Load Generation Balance (LGB) has been prepared considering the diurnal and seasonal load and generation variations across the country. Accordingly, nine number of load-generation scenarios have been identified corresponding to Monsoon, Summer, and Winter seasons along with three points on daily load curve for each season viz. Solar max, Peak demand, and Off-peak demand.

Detailed overview of the load generation balance preparation and challenges observed while balancing the same have been brought out in **Chapter-3**. While preparing LGB for nine scenarios, merit order economic dispatch of thermal generations and RPO obligations of states have been taken into consideration. Maximum and minimum demand of 368GW and 234GW respectively have been considered in 2029-30 timeframe while working out the LGBs. ESS Charging has been considered as load in Solar Max scenarios and during discharging as Generation in other scenarios

Network expansion schemes have been planned and being planned to cater the RE integration and Green Hydrogen(GH) and Green Ammonia(GA) demand requirements. Accordingly, year on year progressive addition of transmission system in ISTS network in terms of new transmission lines (ckm) and substations (MVA) upto 2029-30, and its corresponding broad estimated cost has also been brought out in the report. Cumulatively by 2029-30, transmission schemes comprising of 55,430 ckm of transmission lines and transformation capacity of 6,48,080 MVA at estimated cost of Rs 3,42,565 Cr. is expected to be added in the grid. The Inter-Regional (IR) transmission capacity is expected to grow from present level of 1,18,740MW to about 1,34,540MW by 2029-30.

Chapter-4 to **Chapter-8** is dedicated to each of the five regions, i.e., one Chapter for each Region, where detailed scope of works and implementation timeframe along with schematic of new ISTS schemes including schemes for RE evacuation have been brought out in these Chapters.

India being centrally placed in South Asia is playing a vital role in establishment of interconnections among countries to establish a large South Asian electricity grid. In **Chapter-9**, details on existing, under-construction and under discussion cross-border interconnections between India and neighbouring countries have been brought out.

The summary of new expansion schemes planned, way forward etc. have been mentioned in **Chapter-10**.

Page intentionally left blank

Chapter 1: Background and Objective

India's journey towards a clean and green energy has gained global recognition. India stands 4th globally in Renewable Energy Installed Capacity, with 46% of its total installed electricity capacity i.e., 207 GW out of 451 GW sourced from non-fossil fuel as on Aug'24 out of which Solar and Wind capacity is of about 20% (90 GW) and 11% (47 GW) respectively and balance 15% from other non-fossil sources. India envisaged to enhance the non-Fossil fuel based installed generation capacity to 500 GW out of 776 GW total installed capacity by 2030. 65% of the Total Installed capacity shall be from Non-Fossil Fuel based energy resource comprising of 39% (300GW) from Solar, 13% (100GW) from Wind and balance 13% from other resources such as Hydro, Pumped storage plants, Nuclear etc.

Integration of large scale RE Generation capacity at concentrated areas such as Western Rajasthan and Khavda (Gujarat) may poses severe operational challenges. Further the transmission system established to integrate large solar pockets shall remain unutilised during non-solar hours. To address these challenges, mitigating measures such as deployment of FACTS devices, Energy Storage System including Pumped Storage Plants, adequate reactive compensation (including Dynamic Compensation), Synchronous Condensers are being planned in consultation with stakeholders.

Considering the diurnal and seasonal variation of Generation and Demand across the country preparation of Load Generation Balance (LGB) with fair assumptions is the key to plan an optimised ISTS Transmission Network. Accordingly, considering the optimal dispatch scenarios capturing the availability of the various energy resources and to meet peak power requirements, an optimised ISTS network plan is evolved in consultation with various stakeholders.

In line with the Electricity (Transmission System Planning, Development and Recovery of Inter-State Transmission Charges) Rules, 2021 notified by Ministry of Power, CTU is drawing up plan for Inter-State Transmission System (ISTS) for up to next five years on Rolling basis every year, involving two cycles i.e., from April to September and October to March (Interim Report in Sept and Final Report in March of every financial year) identifying specific transmission projects which are required to be taken up along with their implementation timelines. In this direction, reports on Network Plan 2024-25, Rolling Plan 2026-2027, Rolling Plan 2027-28 & Rolling Plan 2028-29 has already been brought out on 31st Dec 2021, 31st March 2022, 31st March 2023 & 31st March 2024 respectively and the same is available on CTU website. This ISTS Rolling Plan report is being brought out wherein transmission system requirement in ISTS has been identified for 2029-30 timeframe.

This report covers year wise ISTS planned and under implementation across the country to integrate the RE generation and to cater the growing demand for 2029-30 timeframe for nine perspective load-generation scenarios covering three seasons and three different load condition (Solar max, Evening peak and Night off peak) of each season.

Page intentionally left blank

Chapter 2: Power Supply Scenario

India's peak demand met is about 250 GW and as per 20th EPS it is projected to be about 335 GW by 2029-30. Furthermore, bulk consumers such as Green Hydrogen/Ammonia plants of about 20 GW and others of about 18 GW is planned to be integrated to the grid by 2029-30 which will further enhance the projected peak demand.

Non-fossil fuel based Installed generation capacity is around 207 GW (46% of total installed capacity) and is planned to increase to around 471 GW (60% of total installed capacity excluding ESS) by 2029-30 at a CAGR of 17.9%. Further, 35.2 GW of Energy Storage is also planned to integrate in the grid by 2029-30. Installed capacity vis a vis peak demand trend from FY 2014-15 to Aug'24 is depicted in Figure 2-1.

Figure 2-1: Installed Capacity & Demand trend in GW

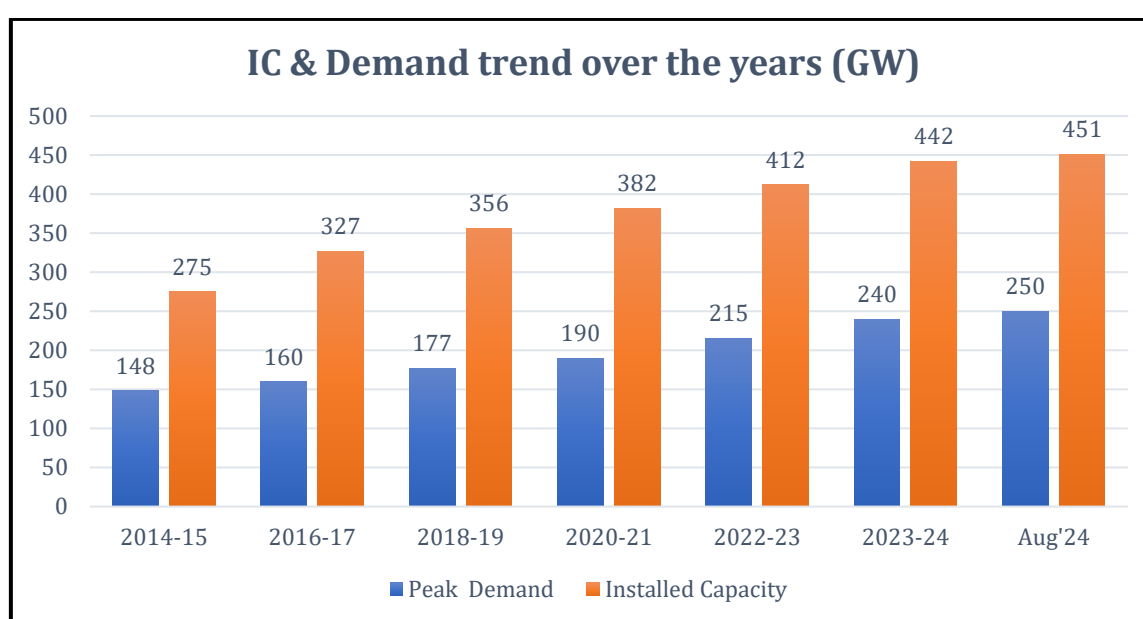

2.1 Power Supply Scenario as of Aug'24

Total installed capacity as on Aug'24 is about 451 GW and the All-India peak demand met is of about 250 GW which is the highest ever peak demand met till date. Region-wise breakup of source wise installed capacity and peak demand met as of Aug'24 is given in the Table 2-1. Fossil and non-fossil fuel-based generation installed capacity accounts for 54% and 46% of total installed generation capacity respectively, which is portrayed in Figure 2-2.

Table 2-1: Installed Capacity and Peak Demand in GW as of Aug '24

Region	Fossil			Non-Fossil				Grand Total	Peak Demand
	Thermal	Gas/ Diesel	Total	Nuclear	Hydro	RES	Total		
NR	58.2	6.0	64.2	1.6	20.8	42.2	64.7	128.9	90.75
WR	76.1	10.8	86.9	3.2	7.6	51.7	62.5	149.4	74.93
SR	53.5	6.3	59.8	3.3	11.8	56.1	71.2	131.0	66.99
ER	29.0	0.1	29.1	0.0	4.8	2.0	6.8	35.9	31.40
NER	1.3	1.7	2.9	0.0	1.9	0.6	2.6	5.5	3.86
All India	218.1	24.8	242.9	8.2	46.9	152.6	207.7	450.6	249.85*

*with diversity

Figure 2-2: Installed Capacity and Peak Demand as of Aug '24

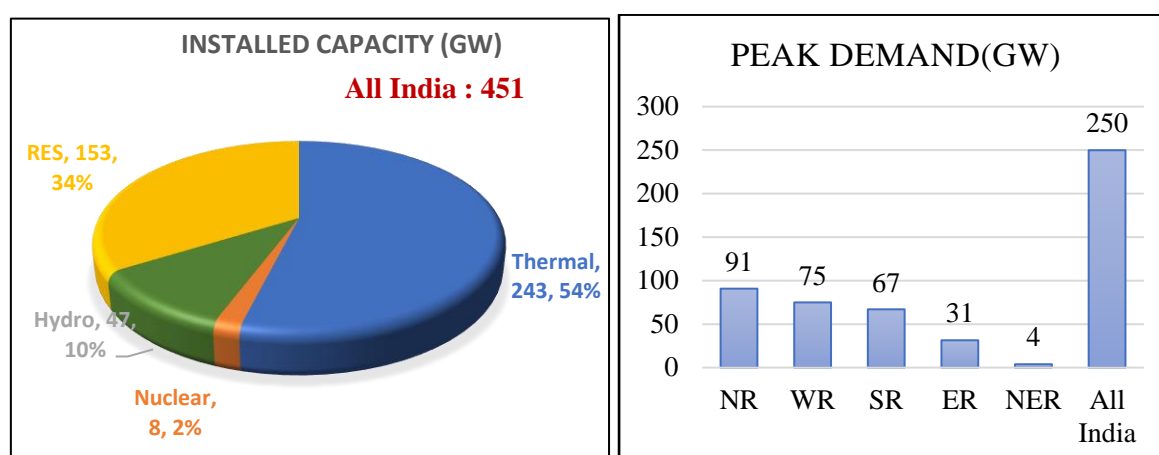

2.2 Envisaged Power Supply Scenario by 2029-30

All India peak demand for 2029-30 is envisaged to be about 335 GW as per 20th Electric Power Survey (EPS) report of CEA. To meet the enhanced demand of about 85GW from present peak demand met of 250 GW, net generation capacity addition of about 325 GW including ESS is planned to be integrated in the grid after accounting the retirement of thermal generation by 2029-30 as anticipated in National Electricity Plan (NEP) of CEA.

Total installed generation capacity for 2029-30 shall be about 776 GW including the pumped and energy storage capacity as per report “Transmission System for Integration of 500 GW RE Capacity by 2030”. The anticipated region-wise breakup of the installed capacity and projected peak demand for 2029-30 are summarised in Table 2-2. Renewable Energy resources generation installed capacity is expected to be about 51% of total installed generation capacity, which is shown in Figure 2-2.

Table 2-2: Projected Installed Capacity & Peak Demand by FY 2029-30

Region	Fossil			Non-Fossil				ESS	Grand Total	Peak Demand
	Thermal	Gas	Total	Nuclear	Hydro	RES	Total			
NR	53.6	3.6	57.2	3.0	25.3	127.8	156.1	6.7	220.0	116.7
WR	93.4	10.1	103.6	3.2	6.1	125.9	135.2	8.1	246.8	107.1
SR	52.9	1.5	54.4	5.8	12.4	137.6	155.8	19.0	229.2	97.4
ER	51.4	0.0	51.4	0.0	14.0	2.5	16.5	1.5	69.5	45.8
NER	0.8	2.2	3.0	0.0	5.4	2.4	7.7	0.0	10.7	5.8
All India	252.1	17.5	269.6	12.1	63.1	396.2	471.4	35.2	776.2	334.8

Figure 2-3: Projected Installed Capacity & Peak Demand by FY 2029-30

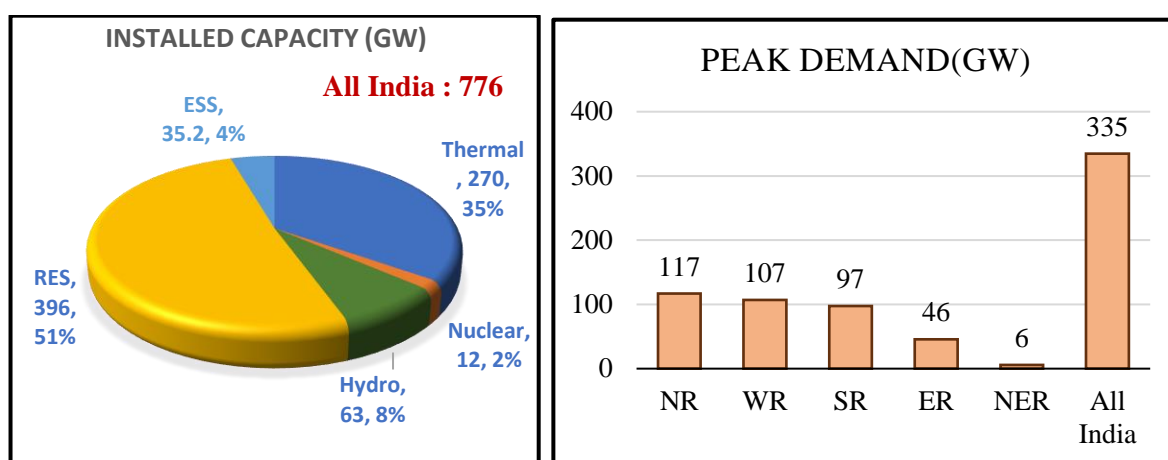

The region wise growth in demand and fuel type wise increase in installed generation capacity for 2029-30 from Aug'24 is tabulated below in Table 2-3.

	Peak Demand (GW)				Generation IC (GW)				
	As on Aug '24	2029-30	Growth	CAGR	As on Aug '24	2029-30	Diff	CAGR	
NR	90.75	116.75	26.00	5.2%	Thermal	218.06	252.10	34.04	2.9%
WR	74.93	107.05	32.12	7.4%	Gas	24.82	17.46	-7.35	-6.8%
SR	66.99	97.44	30.45	7.8%	Nuclear	8.18	12.08	3.90	8.1%
ER	31.40	45.75	14.35	7.8%	Hydro	46.93	63.12	16.20	6.1%
NER	3.86	5.84	1.98	8.6%	Solar	89.43	277.64	188.21	25.4%
All India	249.85	334.81	84.96	6.0%	Other RE+ESS	63.18	153.76	90.57	19.5%
					Total	450.60	776.17	325.57	11.5%

Table 2-3: Peak demand & Generation IC in Aug'24 and 2029-30

Page intentionally left blank

Chapter 3: All India

Renewable-based generation installed capacity in total installed capacity mix is expected to change from 34% at present to about 51% by the year 2029-30. Further, it is going to continuously change with integration of increasing renewable energy plants in the Indian power sector. To plan transmission network for meeting electricity requirement of the country, first it is important to understand the locations of generation pockets and load centre in wide Indian demography. Most of the conventional thermal generation are in eastern part of the India due to availability of coal-reserves and hydro-potential is concentrated in Himalayan/Sub-Himalayan Ranges whereas, new generation addition in the form of renewable energy is emerging in northern, western and southern part of India as depicted in Figure 3-1 which makes Indian power sector one of the most challenging and diversified. To meet energy demand of the country from conventional generation, strong backbone transmission system is already planned and implemented in past decades. With the advent of renewable-based generation addition, new transmission system is being planned and implemented which is resulting in changed power flow pattern on existing transmission system. It becomes important to understand diurnal and seasonal regional power exchanges taking place depending upon the generation and demand of a region. Therefore, any additional transmission system needs to be planned to cater the new load-generation scenario.

Figure 3-1: India's map showing various generations in different parts of the country

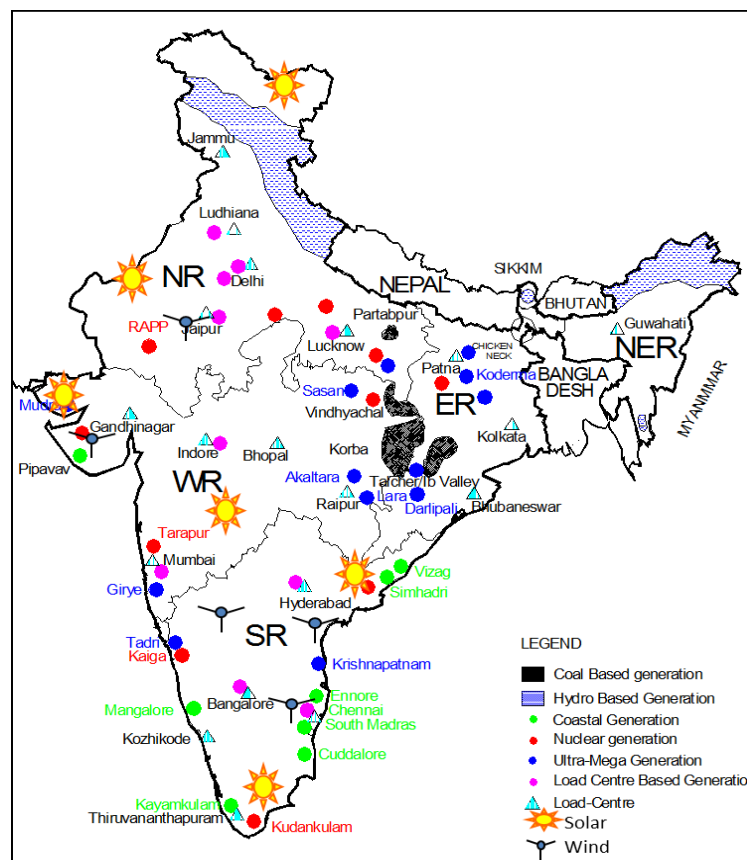

Periodic assessment of transmission requirement under ISTS is made part of this report. Here it is to mention that substantial solar generation capacity addition has been envisaged in future

which shall only generate in daytime. A region having a high solar installed capacity shall become an exporter of power during the afternoon and importer of the power during evening.

To study such phenomenon and analyses power flow patterns in transmission network, various scenarios were identified. Accordingly, nine load generation balance scenarios were prepared corresponding to Monsoon, Summer, and Winter season along with three points on daily load curve for each season. Details about the same will be discussed in next section.

3.1 Load Generation Balance

To replicate and simulate seasonal power requirement variations on annual basis, three load-generation scenarios within a day in three different seasons were chosen. Three points on load curves were identified for each day i.e. Solar max (afternoon), Peak load (evening) and Off-peak load (night). Further, the same was carried out for three seasons viz. Monsoon (August), Summer (June) and Winter (February). Accordingly, load generation has been prepared for following nine scenarios:

- Aug'29: Solar max (Scenario-1), Evening Peak (Scenario-2) and Night off-peak (Scenario-3)
- Jun'29: Solar max (Scenario-4), Evening Peak (Scenario-5) and Night off-peak (Scenario-6)
- Feb'30: Solar max (Scenario-7), Evening Peak (Scenario-8) and Night off-peak (Scenario-9)

During afternoon hours, solar generation is at its peak and thermal generation requirement is minimal. While in evening, solar generation is zero and the thermal generation requirement is maximum. Load Generation Balance (LGB) for above mentioned nine scenarios was prepared. To prepare load generation balance, details about the selection of points on load curve and generation dispatching philosophies are discussed subsequently.

All India peak demand considered for current study timeframe 2029-30 is about 335 GW as per 20th EPS. Further an additional demand of Green Hydrogen/Ammonia of about 22 GW and bulk consumer of about 18 GW has been considered as direct drawl from ISTS. To find out variation of this demand for nine scenarios, demand pattern of calendar year 2023 for the three representative months of three seasons were collected from Grid Controller of India Ltd. for monsoon (Aug-23), summer (Jun-23) and for winter (Feb-23). The data comprises of demand profile of all the days of the month with resolution of 5 mins time interval. Three load conditions each corresponding to solar max, evening peak and night off peak were selected from the representative demand curve of three seasons as depicted in Figure 3-2, Figure 3-3 & Figure 3-4 below. For evening peak scenario and night off peak scenario, maximum demand (between 3:55 pm to 11:55 pm) and minimum demand (between midnight to 06:00 am) were considered respectively. However, for solar max scenario, maximum demand corresponding to noon (12:00 pm) was considered. To obtain the demand factors for study time-frame of 2029-30, demand corresponding to these load condition were divided by maximum All

India/regional demand of the corresponding year i.e. 2023. All India/regional demand factors for different scenarios of 2029-30 are shown in Figure 3-5.

Figure 3-2: Summer (June'23) Load Curve

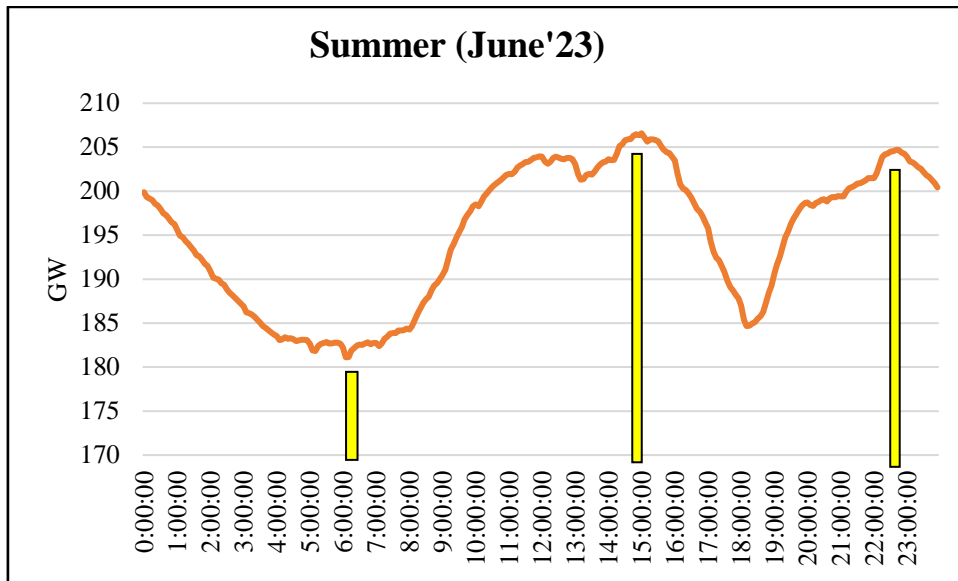

Figure 3-3: Monsoon (Aug'23) Load Curve

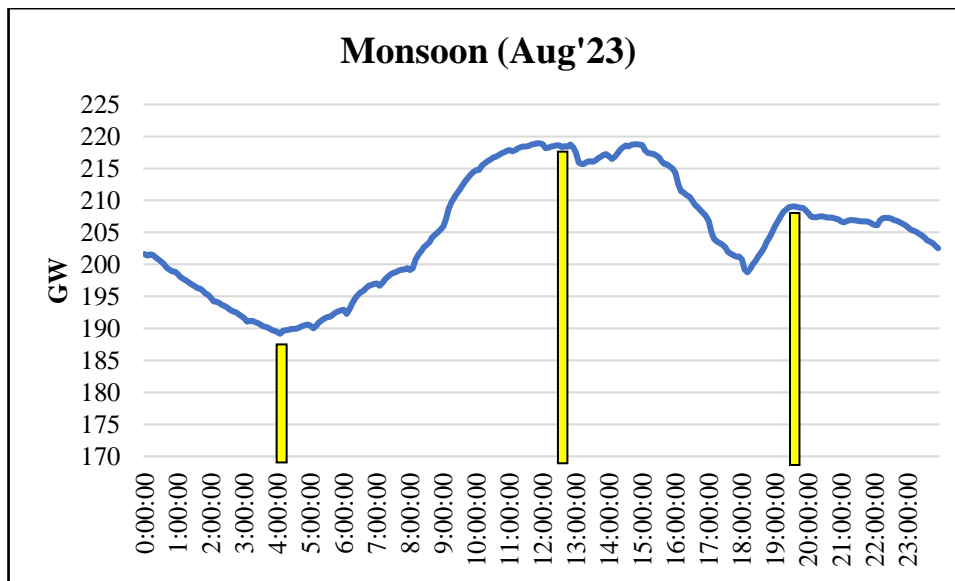

Figure 3-4: Winter (Feb'23) Load Curve

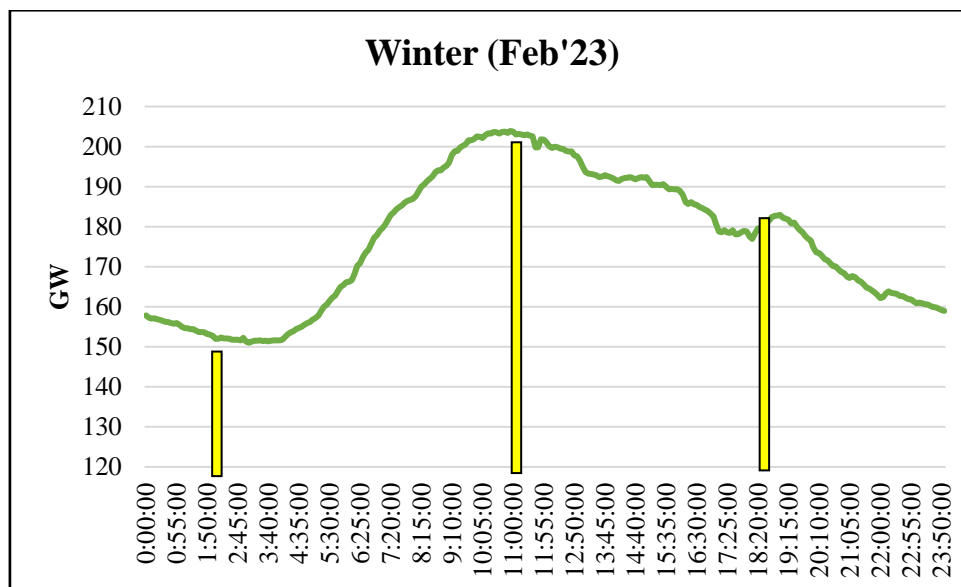

Figure 3-5: Demand factors considered for present study

		Demand Factor					
Scenarios	Monsoon Solar Max (Sc-1)	0.98	0.92	0.98	0.96	0.9	0.77
	Monsoon Evening Peak (Sc-2)	0.91	0.93	0.87	0.77	0.96	0.76
	Monsoon Night Off Peak (Sc-3)	0.73	0.72	0.66	0.66	0.81	0.59
	Summer Solar Max (Sc-4)	0.91	0.83	0.91	0.86	0.94	0.7
	Summer Evening Peak (Sc-5)	0.9	0.95	0.86	0.74	0.89	0.73
	Summer Night Off Peak (Sc-6)	0.67	0.66	0.63	0.62	0.69	0.62
	Winter Solar Max (Sc-7)	0.87	0.73	0.93	0.93	0.68	0.58
	Winter Evening Peak (Sc-8)	0.88	0.61	0.85	0.69	0.73	0.77
	Winter Night Off Peak (Sc-9)	0.58	0.41	0.69	0.59	0.59	0.41
		All India	NR	WR	SR	ER	NER

To meet the anticipated demand in different scenarios, various sources of generations viz. Thermal, Nuclear, Hydro, Gas, Solar & Wind are available. However, despatch of some of these generators shall be as per their diurnal and seasonal variation. Each generation except thermal generation in a region was despatched as per the despatch factors considered in regional chapters.

RE has been considered as must-run, at first the demand was balanced by RE generation. Since all utilities have RE RPO obligation, total RE generation has been apportioned as per RE RPO to all regions based on their projected EPS demand. Further, for accounting the availability of solar roof-top generation, equivalent demand was reduced from respective regions. After

determining the demand met by renewable energy, nuclear and hydro generation, remaining demand was met by Thermal.

Evening peak scenario of each month was setup first as the number of thermal units required on bar shall be maximum. Total thermal generation requirement for the evening peak scenario was apportioned between State and Central sector thermal generations as per their installed capacity in each region. Further, state thermal generation requirement was divided among the states as per their maximum demand in respective month of 2023. After obtaining state thermal generation requirement, thermal units were dispatched at technical maximum (90%) in merit order for each state.

ISGS, CGS & IPP thermal plants with lower variable cost were dispatched at technical maximum (90%) region wise progressively. To meet the demand of any deficit region thermal generation dispatches from other regions considering all India merit order for evening peak scenario was considered. For night off-peak scenario, on bar thermal units were scaled down proportionately.

While preparing the present LGB for Solar max scenario, some plants were switched off to balance the load generation while running all the on-bar thermal plants at technical minimum of 40% as per recent CEA (Flexible operation of coal based thermal power generating units) regulation 2022. Accordingly, thermal plants with higher cost (on merit order basis) were switched off region wise progressively till the LGB is balanced.

It is observed that in the Solar max scenario there is surplus power available in the grid. It is due to availability of peak solar generation and lesser demand in the noon. This surplus is on account of keeping the same number of thermal plants operating at technical minimum (40%) in Solar max scenario which are required to meet evening peak demand. Even after considering the flexibility exhibited by gas and hydro generation between the evening peak and Solar max scenario the surplus generation of about 51 GW dispatches is observed. To absorb the maximum RE generation during the daytime most of the thermal units are required to shut down necessitating the requirement of two-shift operation of thermal generation or more energy storage plants in the grid. Further in winter evening peak a shortage of about 10 GW of generation is observed due to non-availability of solar generation.

Based on above philosophy, LGB prepared for different scenarios are depicted in Figure 3-6, Figure 3-7, Figure 3-8 along with regional surplus/deficit scenario and details about the same are attached at **Annex-3.1**.

Monsoon Aug'2029

Figure 3-6:LGB for Monsoon (Aug'2029)

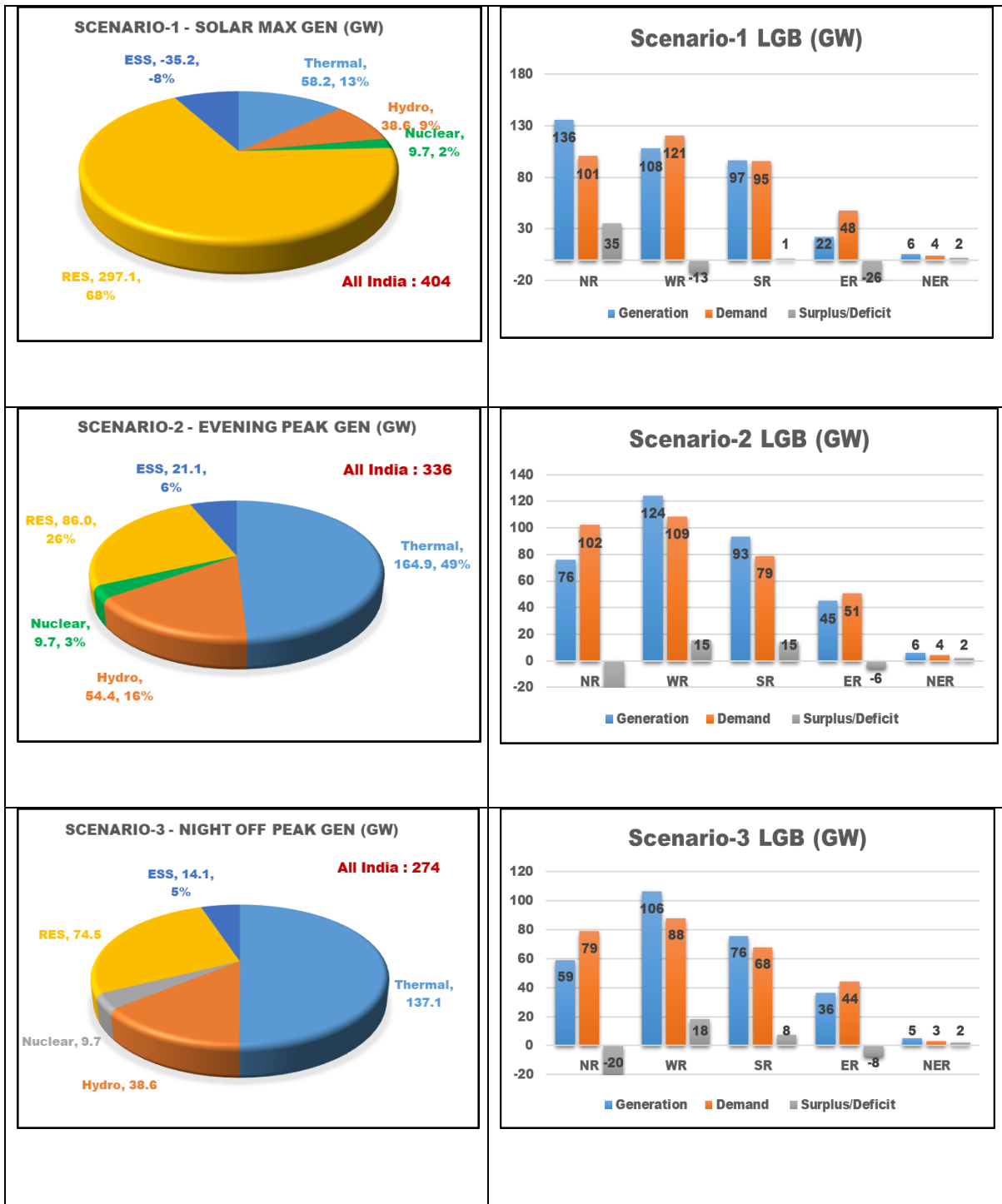

Summer June'2029

Figure 3-7: LGB for Summer (June'2029)

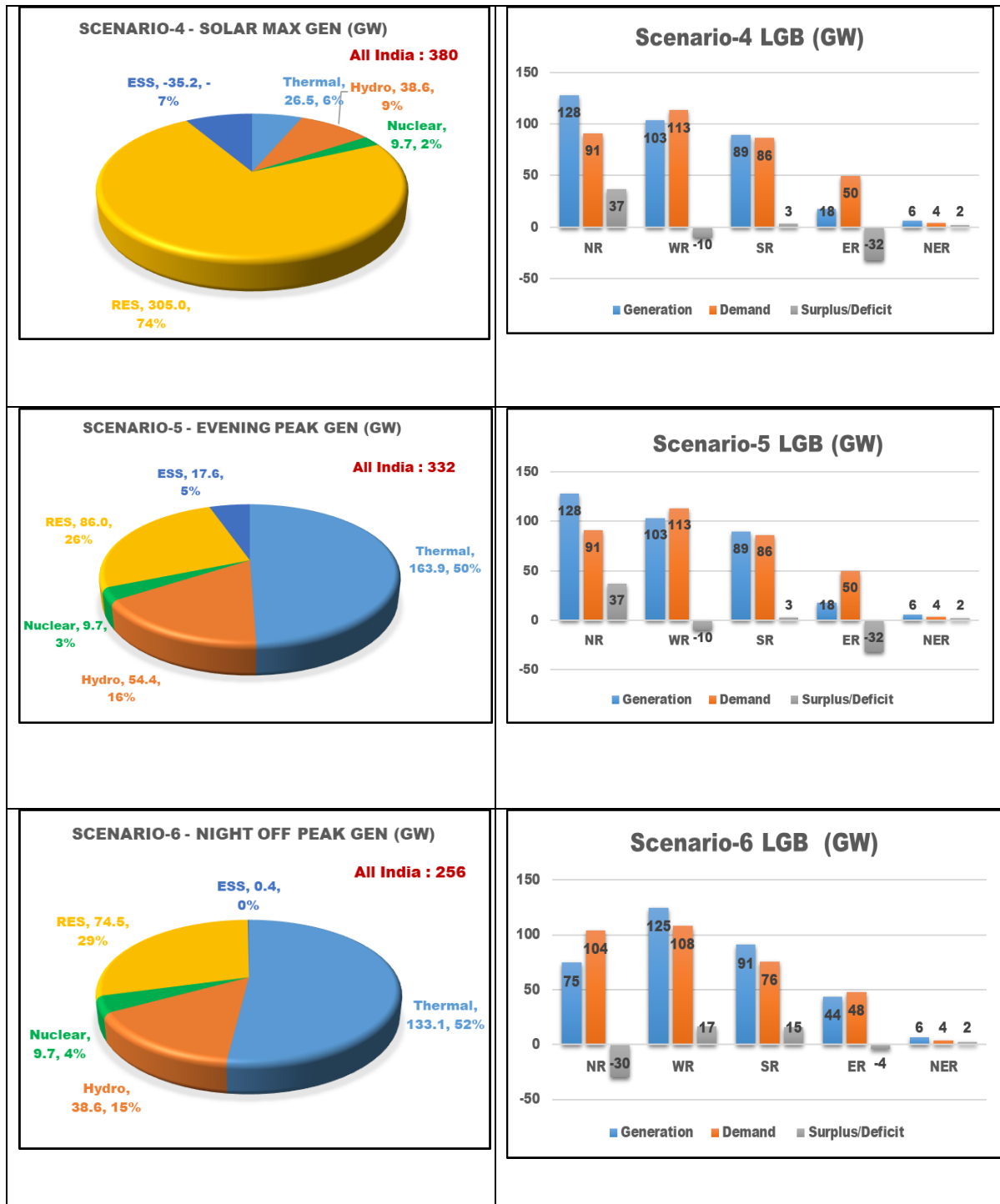

Winter Feb'2030

Figure 3-8:LGB for Winter (Feb'2030)

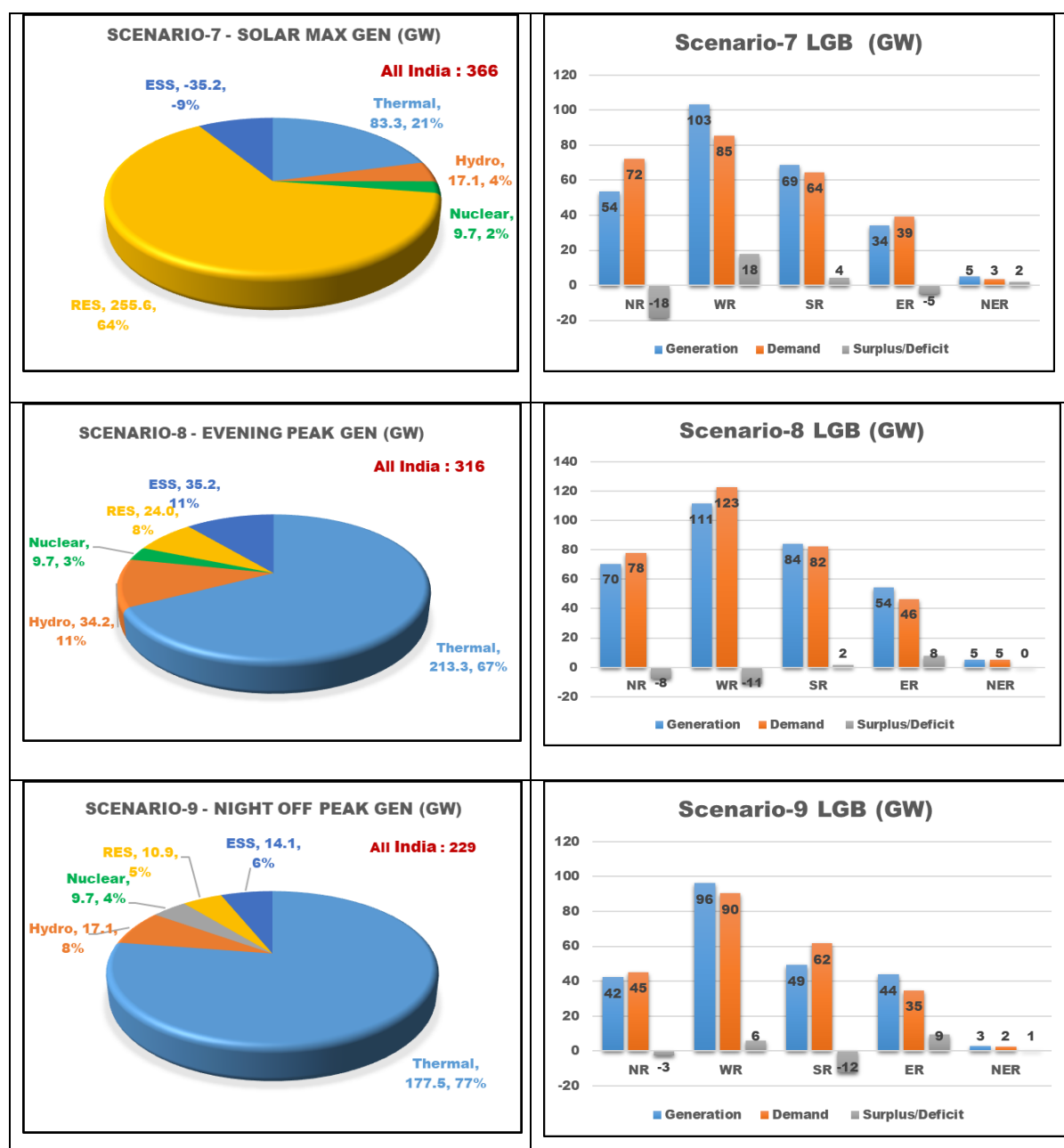

Out of these nine scenarios, Scenario-1(Aug'29 Solar max) and Scenario-9 (Feb'30 Night off peak) corresponds to two extreme cases with respect to demand i.e., highest demand (368 GW) and lowest demand (234 GW) scenarios respectively. In all other scenarios, all India demand is varying between these two demands as per demand factors. Further Scenario-4 corresponds to maximum RE generation share to meet the demand of that scenario. Based on LGB, region wise surplus/deficit in each scenario is summarised in Table 3-1 Furthermore, both maximum surplus and deficit of each region is highlighted too in Table 3-1.

Table 3-1: Regional Surplus/Deficit summary in MW

Surplus (+) / Deficit (-)	Monsoon (Aug'29)			Summer (Jun'29)			Winter (Feb'30)		
	1	2	3	4	5	6	7	8	9
Scenario No. / Region	Solar Max	Evening Peak Load	Off Peak	Solar Max	Evening Peak Load	Off Peak	Solar Max	Evening Peak Load	Off Peak
NR	35140	-26039	-19880	37025	-29613	-18453	43463	-7613	-2799
WR	-12734	15441	18266	-9877	16507	17955	-16566	-11194	5855
SR	1373	14624	7675	3140	15429	4102	-9851	1793	-12460
ER	-25728	-5697	-7671	-32074	-4111	-5023	-17069	7778	9254
NER	1732	2121	1942	2275	2238	1781	903	106	599

From the above table it may be inferred that:

- NR is importing power in evening peak scenario whereas, it is exporting power in solar max scenario due to high solar generation in NR. Maximum import of power is happening in Summer (June) evening peak load scenario & Maximum export of power is in Winter (Feb) solar max scenario.
- WR exports the power in all scenarios except solar max scenarios. Maximum import of about 17 GW is happening in winter (Feb) solar max scenario.
- SR is mostly expected to export power except in winter season. Maximum export of power is 16 GW in Summer (Jun) evening peak scenario, whereas maximum import of the order of 12 GW is taking place in the Winter (February) night off peak scenario.
- ER is importing power in high renewable generation scenarios due to RE RPO requirements of ER. It shall not be able to meet its RPO requirement from its own regional RE and has to import RE power from neighbouring regions.
- NER mostly exports power in all scenarios with maximum export of 2 GW in Summer(June) solar max scenario.

Considering the above LGB for nine scenarios, load flow cases are being prepared for detailed studies to assess the adequacy of Inter State Transmission System including inter-regional corridors planned to cater the power transfer requirement across the region in study timeframe of FY 2029-30. Study results of the same shall be included in final rolling plan report.

3.2 ISTS Expansion upto 2029-30

3.3.1 Summary of ISTS network

Summary of ckm addition, MVA addition and the broad estimated cost of ISTS network *under construction* are tabulated below in Table 3-4, Table 3-5 & Table 3-6 respectively.

Table 3-2: Under Construction Transmission Line (in ckm)

Sl. No.	FY	WR	SR	NR	ER	NER	Total
1	2024-25	3,479	1,611	7,367	-	711	13,168
2	2025-26	1,862	1,260	6,186	238	230	9,776
3	2026-27	1,880	273	-	-	271	2,424
4	2027-28	-	-	-	-	-	-
5	2028-29	470	280	2,028	-	-	2,778
6	2029-30	-	-	-	-	-	-
	Total	7,691	3,424	15,581	238	1,212	28,146

Table 3-3: Under Construction Transformation Capacity (in MVA)

Sl. No.	FY	WR	SR	NR	ER	NER	Total
1	2024-25	42,500	18,000	57,185	1,250	320	1,19,255
2	2025-26	31,000	27,000	49,215	1,500	1,720	1,10,435
3	2026-27	18,500	2,000	-	500	-	21,000
4	2027-28	-	-	-	-	-	-
5	2028-29	4,630	1,630	6,630	-	-	12,890
6	2029-30	-	-	-	-	-	-
	Total	96,630	48,630	1,13,030	3,250	2,040	2,63,580

Table 3-4: Broad estimated cost (in ₹ Cr.) (Under Construction)

Sl. No.	FY	WR	SR	NR	ER	NER	Total
1	2024-25	12,383	6,162	23,551	285	1,840	44,220
2	2025-26	13,167	7,782	29,997	1,439	623	53,008
3	2026-27	12,139	577	-	109	73	12,898
4	2027-28	169	-	-	-	8	177
5	2028-29	6,900	6,242	26,967	-	-	40,109
6	2029-30	-	-	-	-	-	-
	Total	₹ 44,758	₹ 20,763	₹ 80,514	₹ 1,833	₹ 2,544	₹ 1,50,412

Summary of ckm addition, MVA addition and the broad estimated cost of ISTS network *under planning/bidding/approval* are tabulated below in Table 3-7, Table 3-8 & Table 3-9 respectively.

Table 3-5: Under planning/bidding/approval Transmission Lines (in ckm)

Sl. No.	FY	WR	SR	NR	ER	NER	Total
1	2025-26	810	-	644	400	40	1,894
2	2026-27	2,330	3,430	8,533	450	-	14,743
3	2027-28	2,470	540	-	50	75	3,135
4	2028-29	608	-	1,964	70	-	2,642
5	2029-30	1,320	-	-	2,340	1,210	4,870
	Total	7,538	3,970	11,141	3,310	1,325	27,284

Table 3-6: Under planning/bidding/approval Transformation Capacity (in MVA)

Sl. No.	FY	WR	SR	NR	ER	NER	Total
1	2025-26	95,100	500	3,890	3,000	-	1,02,490
2	2026-27	74,000	55,000	55,200	3,000	50	1,87,250
3	2027-28	26,500	23,500	-	-	-	50,000
4	2028-29	22,760	-	7,500	-	-	30,260
5	2029-30	9,000	-	-	-	-	9,000
	Total	2,31,360	79,000	68,090	6,000	50	3,84,500

Table 3-7: Broad estimated cost (in ₹ Cr.) (under planning/bidding/approval)

Sl. No.	FY	WR	SR	NR	ER	NER	Total
1	2025-26	5,177	36	3,318	2,541	324	11,395
2	2026-27	18,358	21,811	45,237	2,898	49	88,353
3	2027-28	17,972	5,365	-	413	825	24,575
4	2028-29	12,136	-	12,700	455	-	25,291
5	2029-30	24,836	-	-	15,120	2,502	42,458
	Total	₹ 78,479	₹ 27,212	₹ 61,335	₹ 21,427	₹ 3,700	₹ 1,92,153

In addition to above, transmission schemes of about ₹ 23,122 comprising 3,690 ckm and 47,000 MVA are also under planning, which shall be taken for approval based on the estimated cost of schemes. In this Rolling plan system for about 67 GW is evolved for integration of

RE/conventional generations and drawal requirements of green hydrogen/green ammonia. Summary regarding the same is given in Table 3-8.

Table 3-8 : Transmission system evolved to cater RE integration and GH/GA (in MW)

Sl. No.	FY	RE	Conventional	GH	Total
1	2025-26	1,000	1,200	-	2,200
2	2026-27	30,000	1,474	-	31,474
3	2027-28	6,500	4,400	19,500	30,400
4	2028-29	1,000	1,200	-	2,200
5	2029-30	-	-	-	-
	Total	38,500	8,274	19,500	66,274

3.3.2 Inter-Regional (IR) Capacity

The progressive growth in Inter-Regional (IR) transmission capacity from 2013-14 till 2029-30 is given below in Figure 3-9. As on Aug'24, IR transmission capacity is about 116 GW which is expected to increase to about 135 GW by 2029-30.

Figure 3-9: Growth in IR Capacity (MW)

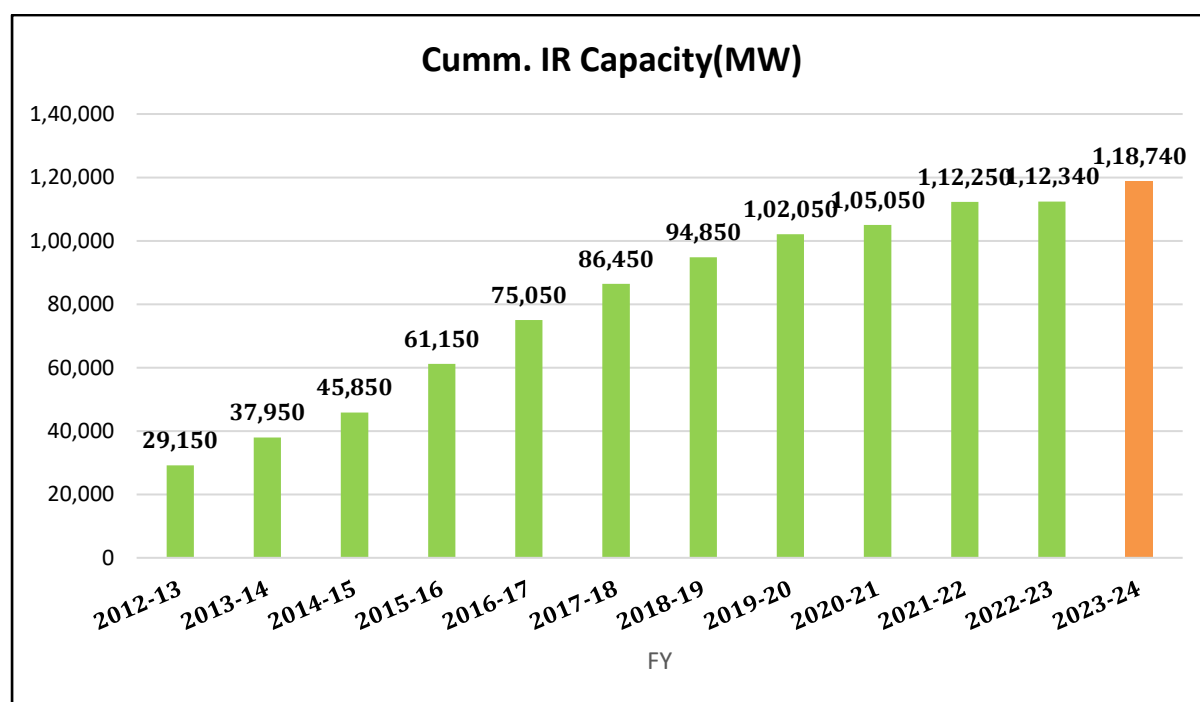

Chapter 4: Northern Region

Northern Region is connected to Western and Eastern Region through 765kV/400kV high capacity corridors along with Back to Back/ HVDCs. The thermal generating stations of Northern Regions are predominantly located in UP, Rajasthan and Haryana whereas hydro generation concentrated into J&K, HP and Uttarakhand. Further, Rajasthan is being a RE rich state comprise of lot of Solar & Wind capacity.

As of now Northern Region imports power from other regions during evening peak load period whereas it will export power to other regions during high RE scenarios in future.

4.1 Power Supply Scenario as on Aug'24

As on Aug'2024, total Installed Capacity of Northern Region is about 128.9 GW and the peak demand met is about 90.75 GW. The state-wise breakup of installed capacity and peak demand met is summarised at Table 4-1 below.

Table 4-1: NR Installed Capacity and Peak Demand as on Aug '24

(All Fig in GW)

State	Generation (GW)							Grand Total	Peak Demand Met (MW)
	Fossil			Non Fossil					
	Thermal	Gas	Total	Nuclear	Hydro	RES (MNRE)	Total		
Delhi	3.6	2.1	5.8	0.1	0.7	0.4	1.2	7.0	8.7
Haryana	8.6	0.6	9.2	0.1	2.3	2.2	4.7	13.9	14.7
Himachal Pradesh	0.1	0.0	0.1	0.0	3.2	1.1	4.4	4.6	1.9
Jammu & Kashmir	0.6	0.3	0.9	0.1	2.3	0.3	2.7	3.6	2.9
Punjab	8.2	0.2	8.4	0.2	3.8	2.1	6.1	14.5	16.1
Rajasthan	13.4	0.8	14.2	0.6	1.9	29.4	31.9	46.2	17.8
UP	21.5	1.0	22.5	0.3	3.4	5.6	9.3	31.8	30.6
Uttarakhand	0.6	0.7	1.3	0.0	2.2	1.0	3.2	4.5	2.9
Chandigarh	0.0	0.0	0.1	0.0	0.1	0.1	0.2	0.2	0.4
Central unallocated	1.4	0.3	1.7	0.2	0.8	0.0	1.0	2.7	95.9
Total	58.2	6.0	64.2	1.6	20.8	42.2	64.7	128.9	90.75

Source: CEA monthly report

From above, it can be concluded that share of non-fossil fuel based generation capacity in total present installed capacity (IC) of 128.9 GW is about 64.7 GW i.e. 50% of total IC. This share would further increase in envisaged scenario of 2029-30 timeframe.

4.2 Envisaged Power Supply Scenario by 2029-30

As per the 20th EPS, Northern Region demand for 2029-30 timeframe is expected to increase to about 116.7 GW. As per the inputs received from various stakeholders, total installed capacity of Northern Region for 2029-30 is expected to be about 220 GW. The state wise bifurcation of installed capacity and peak demand is summarized below at **Table 4-2**.

Table 4-2: NR Installed Capacity and peak demand (2029-30)

(All Fig in GW)

State	Generation (GW)								Peak Demand (GW)	
	Fossil			Non Fossil				ESS		Grand Total
	Thermal	Gas	Total	Nuclear	Hydro	RES (MNRE)	Total			
Delhi	0.5	1.5	2.0	0.0	0.0	0.0	0.0	0.0	2.0	11.0
Haryana	3.6	0.0	3.6	0.1	0.0	0.9	1.0	0.0	4.6	19.7
Himachal Pradesh	0.0	0.0	0.0	0.3	0.0	0.0	0.3	0.0	0.3	3.0
Jammu & Kashmir	0.0	0.2	0.2	1.2	0.0	0.0	1.2	0.0	1.4	4.2
Punjab	5.7	0.0	5.7	1.4	0.0	0.0	1.4	0.0	7.0	19.5
Rajasthan	10.0	0.2	10.2	0.5	0.0	20.7	21.3	0.0	31.5	25.0
UP	21.9	0.0	21.9	1.3	0.0	4.2	5.5	0.0	27.4	39.8
Uttarakhand	0.0	0.0	0.0	2.2	0.0	0.0	2.2	0.0	2.2	3.8
Chandigarh	0.0	0.0	0.0	0.0	0.0	0.0	0.0	0.0	0.0	0.5
Central	11.9	1.8	13.6	14.2	3.0	83.7	100.9	1.5	116.0	-
IPP	0.0	0.0	0.0	4.1	0.0	17.0	21.1	5.2	26.3	-
Rooftop / Other RE	0.0	0.0	0.0	0.0	0.0	5.9	5.9	0.0	5.9	-
Total	53.6	3.6	57.2	25.3	3.0	132.3	160.6	6.7	220	116.7

From above, it is observed that growth in installed capacity of Northern Region is majorly from non-fossil fuel-based generation resources. Share of non-fossil fuel based generation capacity in total present installed capacity (IC) is expected to be increased from 50% to 73%. There is a growth in peak demand of Northern Region from present time-frame (2024-25) to 2029-30 with a CAGR of 4%. The state wise peak demand growth is given at **Table 4-3**.

Table 4-3: Increase in Peak Demand of Various States of NR

(All Fig in MW)

	Peak Demand			
	2024-25	2029-30 (20 th EPS)	Increase in demand	CAGR (%)
Chandigarh	449	533	84	3.5
Delhi	8656	11046	2390	5
Haryana	14,662	19,744	5082	6.1

Peak Demand				
	2024-25	2029-30 (20 th EPS)	Increase in demand	CAGR (%)
Himachal Pradesh	1919	2983	1064	9.2
Jammu & Kashmir & Ladakh	2924	4315	1391	8.1
Punjab	16058	19466	3408	3.9
Rajasthan	17774	25048	7274	7.1
UP	30618	39781	9163	5.4
Uttarakhand	2863	3847	984	6.1
NR	95,923	1,16,745	30,840	4

From the above data it is observed that the CAGR growth of peak demand is maximum for Himachal Pradesh (9.2%) and minimum for Chandigarh (3.5%).

4.3 Load Generation Balance for 2029-30 Timeframe

In Chapter-3, All India Load Generation Balance (LGB) for identified nine scenarios - was prepared as per the methodology finalized in consultation with CTU, CEA and GRID INDIA. This section elaborates the Northern Region Load Generation Balance (LGB) for 2029-30 time-frame. For Northern Region also, three points on the daily load curve i.e. Solar max (afternoon), Peak load (evening) and Off-peak load (night) for three seasons viz. Monsoon (August), Summer (June) and Winter (February) have been considered.

Load generation balance has been prepared considering the generation despatch factors as mentioned at Table 4-4 for the 9 scenarios. Further, thermal generators have been despatched as per the merit order.

Table 4-4: Northern Region Generation Dispatch and Demand Factors

Scenario No & Name	Hydro	Nuclear	Solar	Wind	ESS	Gas	Regional DF
1-Aug Solar Max	70%	80%	90%	50%	-100%	0%	92%
2-Aug Peak Load	95%	80%	0%	70%	60%	50%	93%
3-Aug Night Off Peak	70%	80%	0%	60%	40%	50%	72%
4-Jun Solar Max	70%	80%	90%	50%	-100%	0%	83%
5-Jun Peak Load	95%	80%	0%	70%	50%	50%	95%
6-Jun Night Off Peak	70%	80%	0%	60%	1%	50%	66%
7-Feb Solar Max	30%	80%	90%	10%	-100%	0%	73%
8-Feb Peak Load	60%	80%	0%	35%	100%	50%	61%
9-Feb Night Off Peak	30%	80%	0%	10%	40%	30%	41%

4.4 ISTS Network Expansion Schemes Evolved from Feb'24/Mar'24 to July'24

Various transmission schemes have been discussed/finalized in the Consultative Meeting for Evolution of Transmission System of Northern Region (CMETS-NR) from February/March 2024 to July 2024. Brief of all such deliberated transmission schemes are tabulated below:

Sl. No.	Name of the Transmission Scheme	Scheme Type (RE/ Conventional / Drawal incl strengthening)	Expected Timeframe	Tentative Cost (in Cr.)	Quantum (MW)
Rajasthan and Inter Regional (MP)					
1.	Augmentation of Transformation Capacity at 400/220 kV Bassi (PG) S/s in Rajasthan by 400/220 kV, 1x500 MVA ICT (4 th)	Drawal incl. strengthening	2025-26	49.87	500
2.	Augmentation of Transformation Capacity at 400/220 kV Bhiwadi (PG) S/s in Rajasthan by 400/220 kV, 1x500 MVA ICT (4 th)	Drawal incl. strengthening	2025-26	65.25	500
3.	Augmentation of Transformation Capacity at 400/220 kV Bikaner-II PS in Rajasthan by 400/220 kV, 1x500 MVA ICT (9 th)	RE	2025-26	54.6	-
4.	Augmentation with 400/220 kV, 3x500 MVA (6 th , 7 th & 8 th) ICTs at Fatehgarh-IV PS(Sec-II)	RE	2026-27	167.79	1500
5.	Augmentation with 400/220 kV, 2x500 MVA (3 rd & 4 th) ICTs at Barmer-I PS	RE	2026-27	111.86	1000
6.	Transmission system strengthening to facilitate evacuation of power from Bhadla/Bikaner complex	RE	2026-27	198.75	-
7.	Transmission system for evacuation of power from Fatehgarh/Barmer Complex as part of Rajasthan REZ Ph-IV (Part-4 :3.5 GW) [Fatehgarh/Barmer Complex]	RE	2026-27	12240.87	3500
8.	Transmission system for evacuation of power from Rajasthan REZ Ph-V (Part-1 :4 GW) [Sirohi/Nagaur] Complex, Transmission scheme	RE	2026-27	5027.61	4000
9.	Implementation of 1 no. of 400 kV line bay at 765/400/220kV Bhadla-III PS for interconnection of M/s ReNew Solar (Shakti Six) Pvt. Ltd.	RE	2025-26	13.37	-
10.	Augmentation of Transformation Capacity at 765/400/220kV Bikaner PS in Rajasthan by 400/220kV, 1x500 MVA ICT (4 th)	RE	2025-26	57.59	-
11.	Augmentation with 400/220 kV, 1x500 MVA Transformer (11 th) at Fatehgarh-2 PS	RE	2025-26	50	-
Punjab					
1.	Augmentation of Transformation Capacity at 400/220kV Malerkotla(PG) S/s in Punjab by 400/220kV, 1x500MVA ICT (4 th)	Drawal incl. strengthening	2025-26	88	500
Jammu and Kashmir					
1.	Transmission scheme for evacuation of power from Ratle HEP (850 MW) & Kiru HEP (624 MW)	Conventional	2026-27	1409.54	1474

Details of the schemes are reproduced below state-wise:

4.4.1 Rajasthan

a. Augmentation of Transformation Capacity at 400/220 kV Bassi (PG) S/s in Rajasthan by 400/220 kV, 1x500 MVA ICT (4th)

In 28th CMETS-NR meeting held on 27/03/24, it was stated that at present, 400/220kV Bassi Substation has 2x315+1x500MVA ICTs thus makes total transformation capacity of 1130MVA. POWERGRID in 203rd OCC stated that the loading at ICTs at Bassi is more than 900MW resulting in non-compliance of N-1 Contingency.

From the loading pattern of Bassi ICTs (2x315+1x500) of past one year, it is observed that cumulative maximum loading on 400/220 kV ICTs is about 1100 MW and loading is higher (>850MW) in winter season (Oct'23-Jan'24) for sufficient duration of time. From the analysis, it emerged that loading is breaching N-1 limit for peak Loading of ICTs (total 855 MW on 3 nos. ICTs). Further in CTU planning file for 2026-27 timeframe, ICT loadings are higher (312MW in N-1 Contingency) and may breach the N-1 limit.

As per deliberation held in 213th OCC meeting, with planned a LILO of 220kV Dausa-Sawai Madhopur line at Jaipur South S/s, loading of Bassi ICT is relived marginally (30MW/ICT in N-1 contingency), however 400/220 kV ICTs will still be non-compliant in future.

POWERGRID vide mail dated 22.02.24 confirmed space availability for Augmentation of 400/220kV transformer (4th,1x500MVA) along with transformer bays at 400/220kV Bassi (PG) S/s.

In the meeting, Grid-India stated that at Bassi there is urgent requirement of augmentation of 400/220kV ICT as ICTs were N-1 non-compliant in current winter season. RVPN stated that at present total 6 nos. 220kV feeders are connected to Bassi substation with peak drawl requirement of 1200-1300MW and as per loading pattern, loading is already breaching N-1 limit. Further, with Hindaun ICT and LILO of 220kV Dausa-Sawai Madhopur line at Jaipur South, ICT loading at Bassi may reduce to only some extent. RVPN further stated that

considering future drawl requirement at Bassi S/s, ICT augmentation at Bassi may be considered.

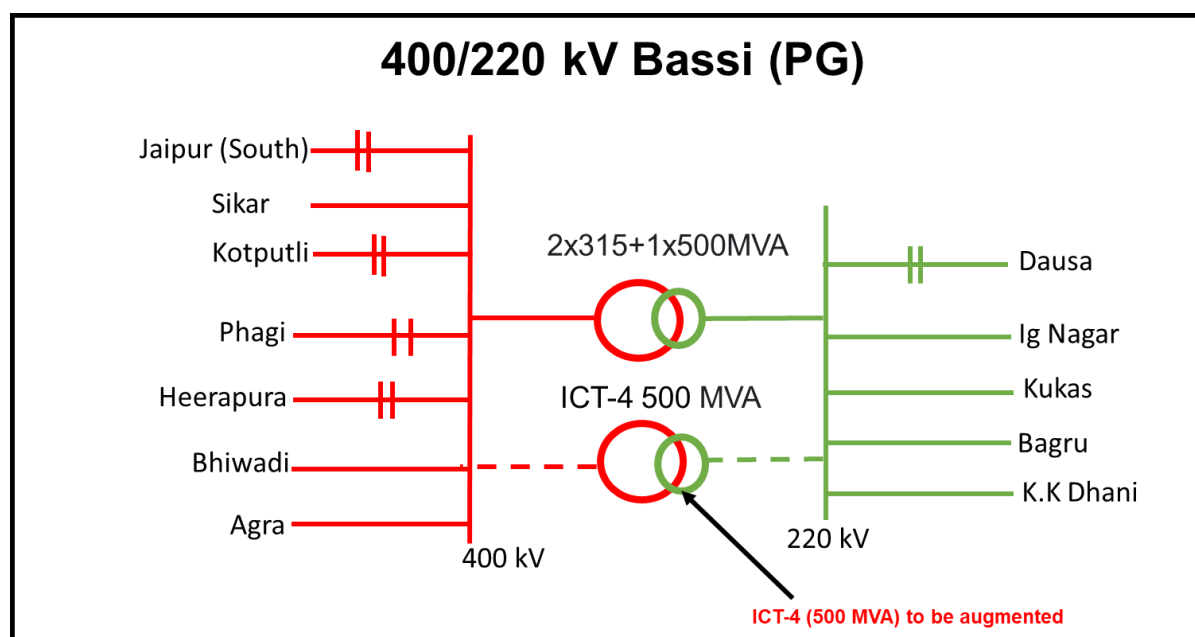

Figure 4-1 : Schematic of 400/220 kV Bassi (PG) S/s

The scheme is under implementation with following details:

Project Name - Augmentation of Transformation Capacity at 400/220 kV Bassi (PG) S/s in Rajasthan by 400/220 kV, 1x500 MVA ICT (4th)

Sl. No.	Scope of the Transmission Scheme	Capacity/km	Implementation timeframe
1	Augmentation of Transformation Capacity at 400/220 kV Bassi (PG) S/s in Rajasthan by 400/220 kV, 1x500 MVA ICT (4th) along with associated transformer bays	500 MVA, 400/220 kV ICT- 1 no. 400 kV ICT bay – 1 no. 220 kV ICT bay – 1 no.	18 months from the date of issuance of CTUIL OM i.e. 14.12.2025
Total Estimated Cost:			INR 49.87 Cr

This scheme was awarded to POWERGRID through RTM mode vide CTU OM dated 14.06.2024 with an implementation time frame of 18 months i.e. anticipated by 14.12.2025.

b. Augmentation of Transformation Capacity at 400/220 kV Bhiwadi (PG) S/s in Rajasthan by 400/220 kV, 1x500 MVA ICT (4th)

It was stated that in 28th CMETS-NR meeting held on 27.03.24, agenda for augmentation of 400/220kV ICT at Bhiwadi Substation was deliberated. In the meeting it was discussed that from the loading pattern of Bhiwadi ICTs (3x315 MVA) , it is observed that cumulative maximum loading on 400/220 kV ICTs is about 820 MW and loading is higher (>600MW) in Jun-Sep'23 & Jan'24-Feb'24 for sufficient duration of time. From the analysis, it emerged that loading is breaching N-1 limit for peak Loading of ICTs (800 MW). Further in CTU planning file, ICT loadings are higher (2x310 MW in case of N-1 Contingency) and may breach the N-1 limit.

POWERGRID vide mail dated 23.02.24 confirmed space availability for Augmentation of 400/220kV transformer (4th,1x500MVA) along with transformer bays at 400/220kV Bhiwadi (PG) S/s. However, 220kV Side of ICT is required to be routed through cable.

In the 29th CMETS-NR held on 17.05.24, Grid-India stated that at Bhiwadi transformer loading are close to N-1 limit and in view of that requirements may be assessed based on future load growth in Bhiwadi complex considering planned interconnections by RVPN/HVPN in future. RVPN stated that at present for Rajasthan, 4 nos. of 220kV feeders are interconnected at Bhiwadi substation and no new interconnection is planned for drawl in future. RVPN also stated that a new 400/220kV substation near Bhiwadi is recently approved by RVPN board to cater future drawl requirement at Bhiwadi complex in view of anticipated load growth. In reply to implementation timeframe of proposed new substation in Bhiwadi, RVPN stated that implementation may take minimum 3 years from now.

POWERGRID stated that loading at Bhiwadi substation are critical and N-1 noncompliant in peak load condition. Further, 2 nos. of 400/220kV ICTs (make 2003 year) already completed 21 years of life and gases are observed to be high due to loading of ICTs. Considering above ICT augmentation is required at Bhiwadi substation. CTU stated that ICT loadings are close to N-1 limit, however HVPN/RVPN need to concur on requirements of ICT augmentation. CTU stated that decision of ICT augmentation may be expedited as Implementation of 400/220kV ICT may take 18-21 months from award and ICT may be available by mid of 2026 only.

CTU enquired RVPN and HVPN to update on the requirement of Augmentation of 400/220kV transformer (4th,1x500MVA) at Bhiwadi S/s based on their assessment.

RVPN stated that power flow over all the existing drawl feeders from Bhiwadi (PG) is already saturated and to meet the future load of Bhiwadi area, other scheme is being planned. RVPN also stated that 220kV Bhiwadi(PG)-Neemrana (RVPN) is being LILOed at Neemrana (PG) and with above LILO part load (~50-70MW) will be shifted from Bhiwadi(PG) to Neemrana(PG) and RVPN may not drawl additional power from existing feeders of Bhiwadi(PG) S/s.

HVPN stated that at present no additional drawl requirement is envisaged in future from Bhiwadi (PG) S/s. However for N-1 compliance, HVPN concurred for Augmentation of 400/220 kV, 500 MVA (4th) ICT at Bhiwadi S/s and same was informed vide HVPN letter

dated 17.05.24.. HVPN also stated that they are planning some ICT augmentation at 220kV intra state network, however it will not impact 400/220kV ICT loading much.

Grid-India suggested that as N-1 noncompliance occurs for short duration of time, replacement of 315MVA ICT with 500MVA ICT may be considered in place of augmentation with 4th ICT at Bhiwadi S/s. POWERGRID stated that even with load diversion (~50-70MW), ICT loadings are close to N-1 limits and considering type of load (critical) as well as with increasing gases trend in existing ICTs, ICT augmentation may be considered. POWERGRID stated that 2nos. of ICTs at Bhiwadi S/s requires continuous inspection & degassing due to high loading of ICTs and they are not able to get shutdown of ICTs from RVPN side due to continuous load demand in Bhiwadi complex and with long outage of ICTs, load will also be impacted.

RVPN stated that in long outage condition of ICTs, there will be severe issues in serving the critical load of Bhiwadi complex which is mainly industrial load and replacement of ICT may also require shutdown. RVPN stated that in view of issues in existing 400/220kV ICTs, frequent shutdown requirement and possible long outages of above ICTs which will impact critical industrial loads in Bhiwadi area , augmentation with 4th ICT may be considered at Bhiwadi substation . HVPN also concurred on the same.

Grid-India stated that as RVPN and HVPN concurred for ICT augmentation requirement to meet N-1 compliance, same is agreeable to them instead of replacement of ICT.

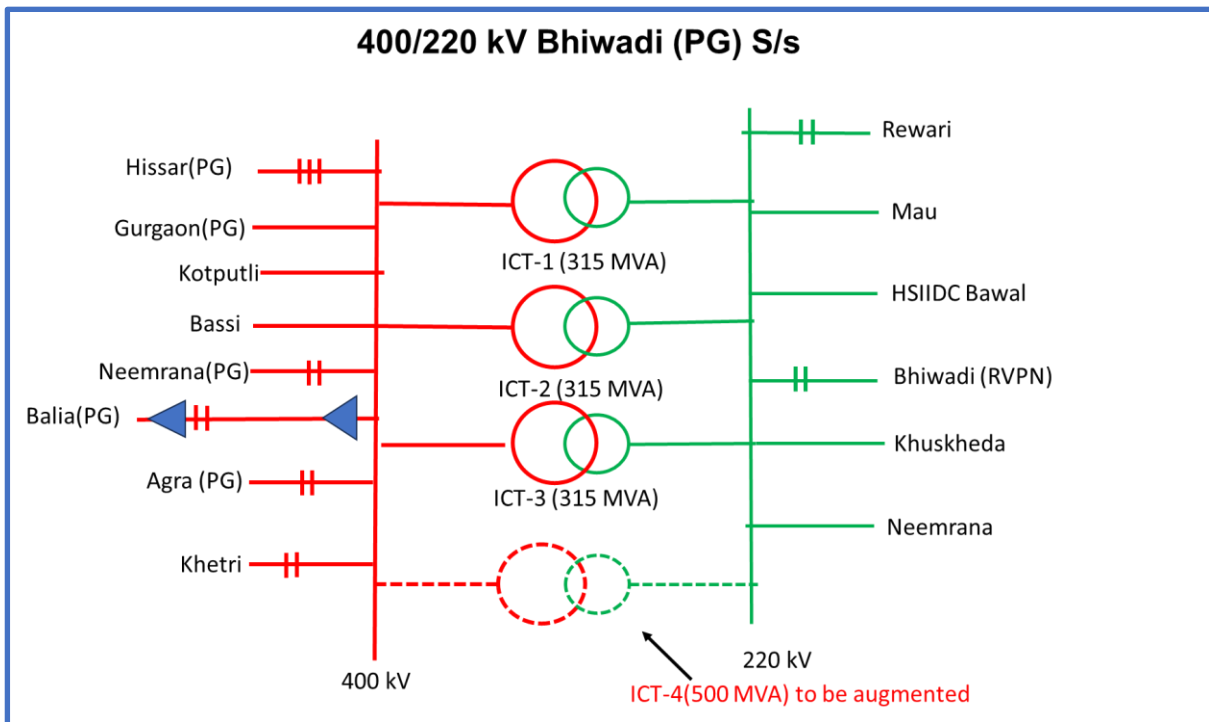

Figure 4-2: Schematic of 400/220 kV Bhiwadi (PG) S/s

The scheme is under implementation with following details:

Project Name - Augmentation of Transformation Capacity at 400/220 kV Bhiwadi (PG) S/s in Rajasthan by 400/220 kV, 1x500 MVA ICT (4th)

Sl. No.	Scope of the Transmission Scheme	Capacity/km	Implementation timeframe
1	Augmentation of Transformation Capacity at 400/220 kV Bhiwadi (PG) S/s in Rajasthan by 400/220 kV, 1x500 MVA ICT (4th) along with associated transformer bays.	<ul style="list-style-type: none"> ➤ 500 MVA, 400/220 kV ICT- 1 no. ➤ 400 kV ICT bay – 1 no. ➤ 220 kV ICT bay – 1 no ➤ 220kV Cable (1 ph)–3200mtr (4x800mtr) (approx.) ➤ 220 kV Cable Termination Kit : 8 nos.. 	18 months from the date of issuance of CTUIL OM i.e. 18.01.2026
Total Estimated Cost:			INR 65.25 Cr

This scheme was awarded to POWERGRID through RTM mode vide CTU OM dated 18.07.2024 with an implementation time frame of 18 months i.e. anticipated by 18.01.2026.

c. Augmentation of Transformation Capacity at 400/220 kV Bikaner-II PS in Rajasthan by 400/220 kV, 1x500 MVA ICT (9th)

In the 29th CMETS-NR meeting held on 17/05/24 It was stated that 400/220 kV Bikaner-II PS is an existing RE pooling station with transformation capacity of 1000 MVA(2x500MVA). Further, 6 no. of 500 MVA 400/220kV, ICTs are under implementation with the schedule progressively from Jun'24 upto Jan'25. Therefore, considering above total transformation capacity at 400/220 kV Bikaner-II PS shall be 4000MVA (8x500MVA) by Jan'25. Considering the total connectivity of 3785 MW granted at 220 kV level at Bikaner-II PS, augmentation of 1x500 MVA, 400/220kV (9th) ICT at Bikaner-II PS shall be required to meet N-1 compliance.

Grid-India (NRLDC) enquired about bus splitting arrangement at 220kV level of Bikaner-II PS. CTUIL stated that there is bus sectionalizer arrangement (normally closed) as per present practise. Grid-India stated that in some of RE pooling stations there are 2 or 3 different 220kV sections with n-1 compliance (400/220kV ICT) in each section. CTU stated that in some pooling stations i.e. Fatehgarh-II PS, Bhadla-II PS where 220kV bus sections are geographically isolated (way apart from each other), accordingly there is no sectionalizer arrangement feasible in two sections and n-1 compliance of 400/220kV ICTs to be ensured in both the sections as per planning criteria. CTU also stated that different configuration of 220kV section arrangement

i.e. 220kV isolated sections in two different directions or 220kV common bus with sectionalizer arrangement (normally closed) is only decided by the TSP based on GA and layout of substation. Based on above n-1 compliance (400/220kV ICT) requirement will be identified. At Bikaner-II PS there is common 220kV bus with bus sectionalizer arrangement which would be normally in closed position, therefore N-1 compliance is being considered on common 220kV bus. Grid-India stated that some common philosophy should be adopted for Grid operation.

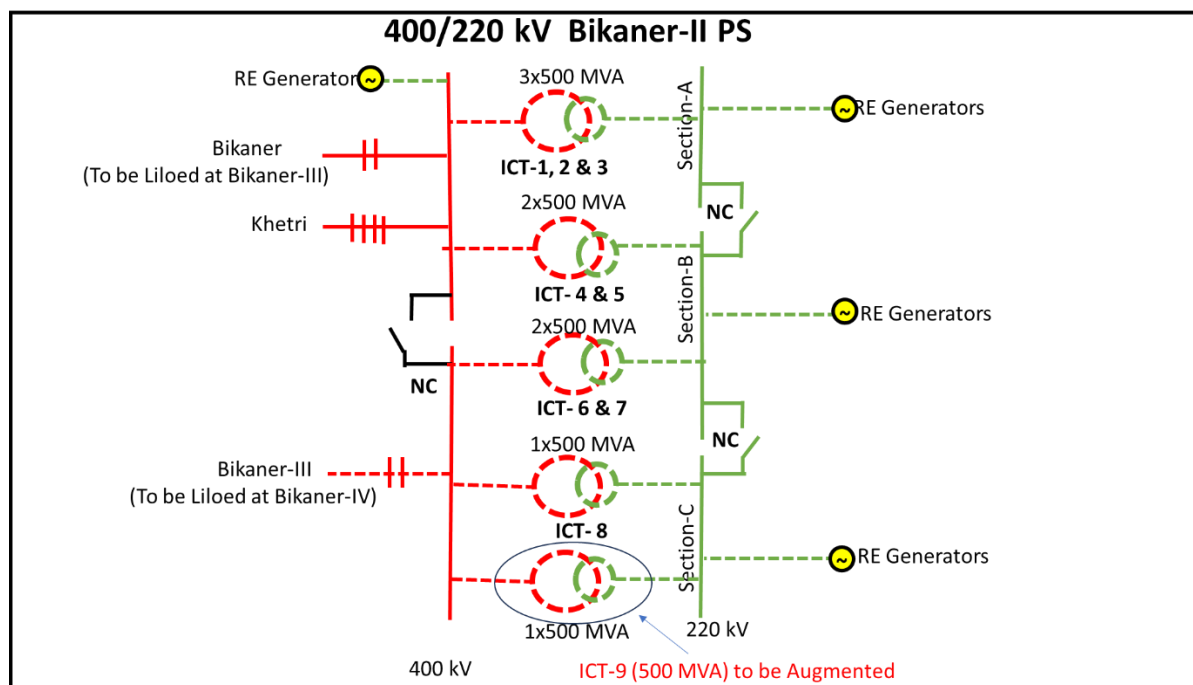

Figure 4-3: Schematic of 400/220 kV Bikaner-II PS

The scheme is under implementation with following details:

Project Name - Augmentation of Transformation Capacity at 400/220 kV Bikaner-II PS in Rajasthan by 400/220 kV, 1x500 MVA ICT (9th)

Sl. No.	Scope of the Transmission Scheme	Capacity/km	Implementation timeframe
1	Augmentation of Transformation Capacity at 400/220 kV Bikaner-II PS in Rajasthan by 400/220 kV, 1x500 MVA ICT (9th) along with associated transformer bays	500 MVA, 400/220 kV ICT- 1 no. 400 kV ICT bay- 1 no. 220 kV ICT bay- 1 no	18 months from the date of issuance of CTUIL OM i.e. 18.01.2026
Total Estimated Cost:			INR 54.60 Cr

This scheme was awarded to POWERGRID through RTM mode vide CTU OM dated 18.07.2024 with an implementation time frame of 18 months i.e. anticipated by 18.01.2026.

d. Augmentation with 400/220 kV 3x500 MVA(6th to 8th) ICTs at Fatehgarh-IV PS(Sec-II)

In the 29th CMETS-NR meeting held on 17/05/24, it was deliberated that at present, total connectivity granted at Fatehgarh-IV PS(Sec-II) is 4980 MW(4880+100 MW on hold due to reallocation matter currently subjudice). Out of this, 3480 MW(3380+100 on hold) is granted at 220 kV and 1500 MW is granted at 400 kV level. Establishment of Fatehgarh-IV PS(Sec-II) and associated transmission system is currently under bidding as part of “Transmission System for evacuation of power from Rajasthan REZ Ph-IV (Part-2:5.5 GW) (Jaisalmer/ Barmer Complex)” and expected to be awarded in May’24.

The above scheme involves establishment of 765/400/220 kV Fatehgarh-IV PS(Sec-II) along with transformation capacity of 4x1500 MVA 765/400 kV ICTs & 5x500 MVA 400/220 kV ICTs. Considering the connectivity of 3480 MW granted at 220 kV level of Fatehgarh-IV PS(Sec-II), augmentation of 3x500 MVA ICTs are required to be taken up matching with the above scheme for evacuation of power as well as to meet N-1 compliance.

Grid-India enquired about RE generation being interconnected at Fatehgarh-IV PS(Sec-I). CTU stated that at Fatehgarh-IV PS (Sec-I), about 2025MW connectivity is granted and both the sections i.e. section-I & II shall be electrically isolated through sectionalizer (normally open) with compliance will be separate for both the sections. Accordingly, N-1 of 400/220kV ICTs is being ensured in both the sections. CEA agreed for the proposal.

Accordingly, the following ICT augmentation scheme is agreed (in 29th CMETS-NR) at Fatehgarh-IV PS(Sec-II) PS in ISTS:

- Augmentation with 400/220 kV, 3x500 MVA (6th ,7th & 8th) ICTs at Fatehgarh-IV PS(Sec-II) along with associated transformer bays

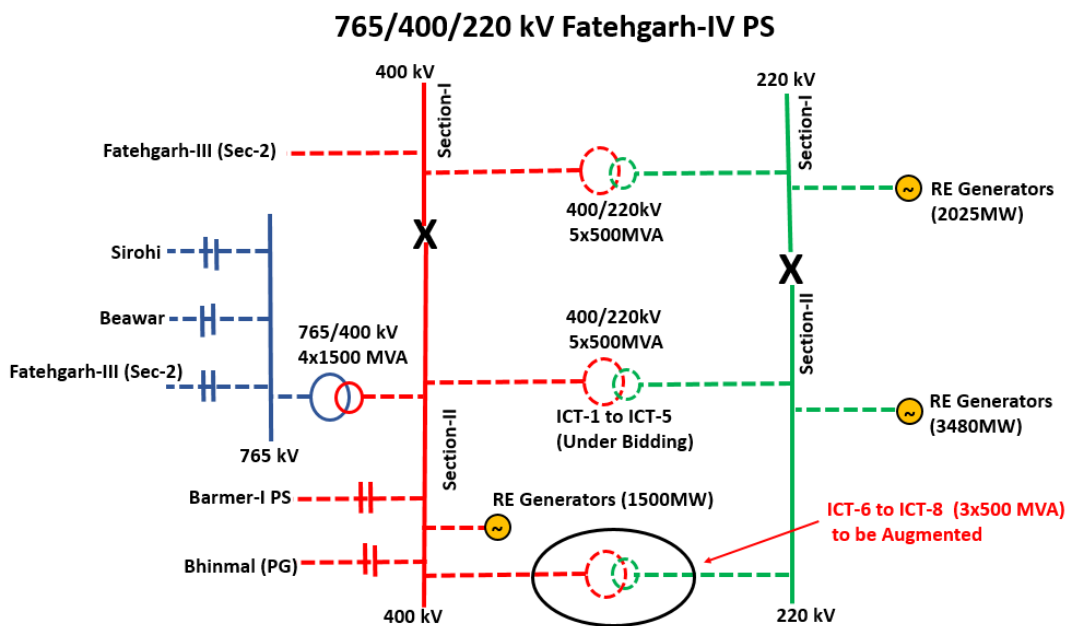

Figure 4-4: Schematic of 765/400/220 kV Fatehgarh-IV PS

Above scheme was also discussed in 21st NCT meeting held on 06/08/24 & NCT approved the scheme of Augmentation with 400/220 kV 3x500 MVA (6th to 8th) ICTs at Fatehgarh-IV PS(Section-II) under TBCB route. The scheme details are as below:

Project Name - Augmentation with 400/220 kV, 3x500 MVA (6th ,7th & 8th) ICTs at Fatehgarh-IV PS(Sec-II)

<i>Sl. No.</i>	<i>Scope of the Transmission Scheme</i>	<i>Item Description</i>	<i>Implementation Timeframe.</i>
1.	Augmentation with 400/220 kV, 3x500 MVA (6 th ,7 th & 8 th) ICTs at Fatehgarh-IV PS(Sec-II) along with associated transformer bays Estimated Cost : 167.79 Cr	<ul style="list-style-type: none"> • 500 MVA, 400/220 kV ICT - 3 nos. • 400kV ICT bays – 3 nos. • 220 kV ICT bay – 3 nos. 	Matching with Rajasthan REZ Ph-IV (Part-2:5.5 GW) Scheme (Rajasthan REZ Ph-IV (Part-2:5.5 GW) Scheme expected SPV transfer: Aug'24)
Total Estimated Cost:			₹ 167.79 Crore

e. Augmentation with 400/220 kV 1x500 MVA(3rd & 4th) ICT at Barmer-I PS

In the 29th CMETS-NR meeting held on 17/05/24, it was deliberated that At present total connectivity granted at Barmer-I PS is 3050 MW at 220 kV. Out of this 3050 MW, 1350 MW connectivity is granted with Transmission System for evacuation of power from Rajasthan REZ Ph-IV (Part-2:5.5 GW) (Jaisalmer/ Barmer Complex) scheme. The connectivity beyond 1350 MW(upto 4000 MW) is being granted with Rajasthan REZ Ph-IV (Part-4:3.5 GW) scheme which was recently approved in the 19th NCT meeting held on 29.04.2024.

Establishment of 765/400/220kV Barmer-I PS (765/400KV: 3x1500MVA, 400/220KV: 2x500MVA) and associated system is currently under bidding as part of “Transmission System for evacuation of power from Rajasthan REZ Ph-IV (Part-2:5.5 GW) (Jaisalmer/Barmer Complex)” and is expected to be awarded in May’24. Therefore, considering the connectivity of 1350 MW granted at 220 kV level of Barmer-I PS with Ph-IV Part-2 scheme, augmentation of 1x500 MVA ICT (3rd) is required to be taken up matching with the above scheme(Rajasthan REZ Ph-IV (Part2:5.5 GW)) for reliable evacuation of power.

CEA stated that with 1350MW quantum at Barmer-I PS, N-1 compliance also needs to be taken care and therefore 2 nos. of 400/220kV ICTs (3rd & 4th) shall be required for evacuation as well as to meet N-1 requirement. CTU stated that considering 4000MW RE quantum (Potential) at 220kV level of Barmer-I PS, total 9 no’s, of ICTs are required for evacuation as

well as to meet N-1 compliance. Out of 9 nos. of ICTs, 2nos. of ICTs (1st & 2nd) were approved as part of Rajasthan REZ Ph-IV (Part-2:5.5 GW) scheme and 5x500MVA ICTs (5th to 9th) is also approved in recent NCT meeting as part of Rajasthan REZ Ph-IV (Part-4:3.5 GW) scheme and with proposed augmentation (3rd ICT), total 8 nos. ICTs is being considered whereas 9th ICT can be taken at later stage to meet N-1 compliance requirement. CEA stated that there is some time gap (5-6 months) in commissioning of two schemes i.e. REZ Ph-IV (Part-2:5.5 GW) & REZ Ph-IV (Part-4:3.5 GW) and for such period 400/220kV ICTs will be n-1 non-compliant. CEA stated that 2x500MVA (3rd & 4th) may be considered. SECI enquired whether GNA Operationalization of RE applicants at Barmer-I PS may also be affected in absence of 4th ICT required to meet N-1 compliance. CTU stated that GNA Operationalization of RE applicants will not be dependent on ICT required to meet N-1 compliance, however considering discussions in meeting, 400/220 kV, 2x500 MVA (3rd & 4th) ICTs at Barmer-I PS is considered to meet power evacuation as well as transformer n-1 requirement.

Accordingly, the following ICT augmentation scheme is agreed (in 29th CMETS-NR) at Fatehgarh-IV PS(Sec-II) PS in ISTS:

Augmentation with 400/220 kV, 2x500 MVA (3rd & 4th) ICTs at Barmer-I PS along with associated transformer bays

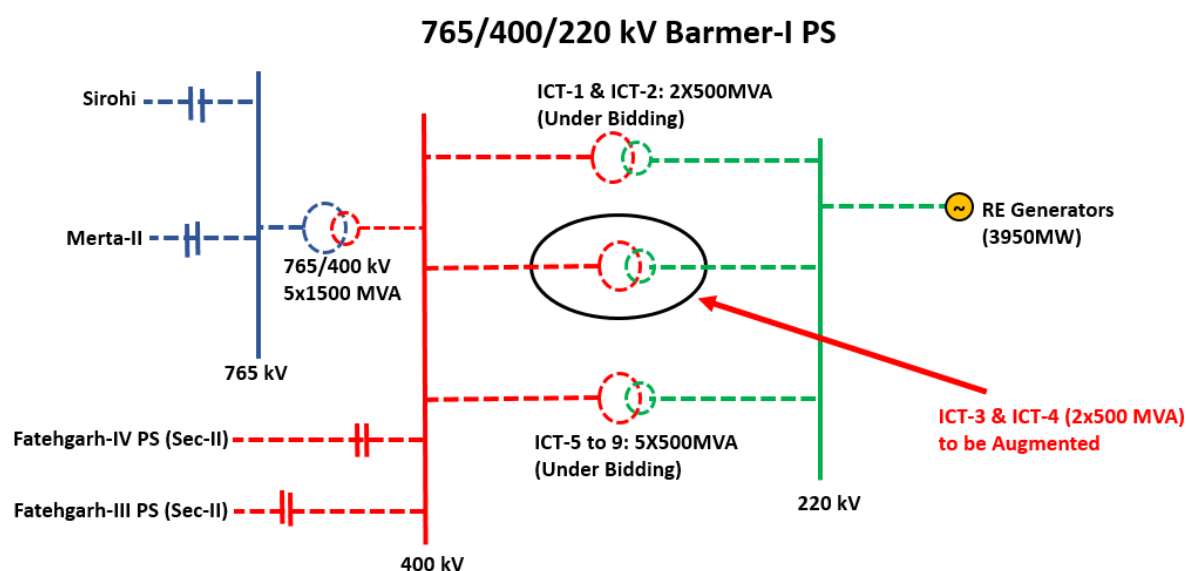

Figure 4-5: Schematic of 765/400/220 kV Barmer-I PS

Above scheme was also discussed in 21st NCT meeting held on 06/08/24 & NCT approved the scheme of Augmentation with 400/220 kV 2x500 MVA (3rd & 4th) ICTs at Barmer-I PS under TBCB route. The scheme details are as below:

Project Name- Augmentation with 400/220 kV, 2x500 MVA (3rd & 4th) ICTs at Barmer-I PS

<i>Sl. No.</i>	<i>Scope of the Transmission Scheme</i>	<i>Item Description</i>	<i>Implementation Timeframe.</i>
2.	Augmentation with 400/220 kV, 2x500 MVA (3 rd & 4 th) ICTs at Barmer-I PS along with associated transformer bays	<ul style="list-style-type: none"> • 500 MVA, 400/220 kV ICT - 2 nos. • 400kV ICT bays – 2 nos. • 220kV ICT bay – 2 nos. 	Matching with Rajasthan REZ Ph-IV (Part-2:5.5 GW) Scheme (Rajasthan REZ Ph-IV (Part-2:5.5 GW) Scheme expected SPV transfer: Aug'24)
Total Estimated Cost:			₹ 111.86 Crore

f. Transmission system strengthening to facilitate evacuation of power from Bhadla/Bikaner complex

Comprehensive Transmission scheme for evacuation of power from Rajasthan REZ Ph-IV (Part-1) (Bikaner Complex) is under implementation for power transfer of 7.7GW incl. 4GW from Bikaner-III PS. The scheme comprises 765kV EHVAC corridor from Bikaner-III PS towards load centers of Delhi/UP. As part of the above scheme, 765 kV Bikaner-III -Neemrana 2xD/c and Neemrana-II – Bareilly (PG) D/c lines are being implemented.

Further, as part of Rajasthan REZ Ph-III (20GW) Transmission scheme, Bhadla-III & Ramgarh PS are being established for integration of 6.5GW & 2.9 GW RE potential respectively. Ramgarh PS is also being inter-connected with Bhadla-III for evacuation of RE power. In order to facilitate evacuation of 9.4GW RE power from Ramgarh/Bhadla-III PS (6.5GW+2.9GW) from Bhadla-III onwards, 765kV Bhadla-III - SikarII D/c line with implementation schedule of Mar'25 [for about 2.9GW power transfer requirement] as well as 6GW HVDC corridor (+800kV Bhadla (HVDC) -Fatehpur (HVDC)) with implementation schedule of Feb'28 (Pole-1) & Aug'28 (Pole-2) is being implemented as part of Ph-III scheme.

Accordingly, in 19th CMETS-NR meeting, 765kV Bhadla-III - Bikaner-III D/c line was agreed to meet evacuation requirement from Bhadla-III PS onwards for some RE generators coming up in 2025-26 as well as Optimal utilization of EHVAC transmission system beyond Bikaner-III PS while providing flexibility of power transfer from Bhadla/Bikaner RE clusters. The scheme is under bidding.

To facilitate above evacuation of power as well as to meet N-1 criteria (beyond 765kV Bareilly S/s), additional 400 kV corridor i.e. 400kV Bareilly(765/400kV) – Bareilly(PG) D/c line (Quad) (2nd) along with augmentation with 1x1500 MVA, 765/400 kV ICT at Bareilly (765/400kV) S/s (3rd) is proposed. The above strengthening scheme is also included as part of connectivity system of various RE applications granted at Bikaner-III.

CEA agreed for the proposal, however they enquired about short circuit of 400kV Bareilly(765/400kV) & Bareilly(PG) S/s. CTU stated that short circuit level of 400kV Bareilly(765/400kV) is about 52kA (designed capacity:50 kA) & 400kV Bareilly(PG) S/s is about 51kA (designed capacity: 40 kA), however with above proposed scheme short circuit level increase marginally (1-2kA) on both the substations. CTU stated that to reduce short circuit level of various substation in NR, wherein short circuit level is already high (from designed capacity), measures will be taken as part of comprehensive scheme in a phased manner. Grid India stated that scheme is agreeable and they do not have any comment on above scheme.

POWERGRID vide mail 21.01.23 confirmed the space availability for 765/400kV ICT (3rd) at Bareilly (PG) (765/400kV) as well as 2 nos. of 400kV line bays each at Bareilly (PG) (765/400kV) and Bareilly (PG) (400kV).

NCT (19th NCT held on 29/04/2024) decided implementation of the Transmission system strengthening to facilitate evacuation of power from Bhadla/Bikaner complex to be undertaken under TBCB.

Summary of the scheme is given below:

SI No.	Name of the scheme and tentative implementation timeframe	Estimated Cost (₹ Crores)	Remarks
1.	Transmission system strengthening to facilitate evacuation of power from Bhadla/Bikaner complex Tentative implementation timeframe : 18 months from the date of SPV transfer	198.75	Recommended under TBCB route with PFCCL as BPC

Detailed scope of the scheme is given below:

Sl. No.	Scope of the Transmission Scheme	Item Description
1.	400 kV Bareilly (765/400 kV) – Bareilly (PG) D/c line (Quad) (2 nd)	Line length : 4 kms <ul style="list-style-type: none"> • 400 kV line bays -2 Nos. (at Bareilly (765/400 kV) S/s) • 400 kV line bays - 2 Nos. (at Bareilly (PG) S/s)
2.	Augmentation with 1x1500 MVA, 765/400 kV ICT (3 rd) at Bareilly (765/400 kV) S/s	<ul style="list-style-type: none"> • 765/400 kV, 1500 MVA ICT - 1 No. • 765 kV ICT bay - 1 No. • 400 kV ICT bay - 1 No.

Note:

- The line lengths mentioned above are approximate as the exact length shall be obtained after the detailed survey
- POWERGRID to provide space for 2 Nos. of 400 kV line bays each at Bareilly (765/400 kV) and 400 kV Bareilly (PG) S/s
- POWERGRID to provide space for 1500 MVA ICT at Bareilly (765/400 kV) along with its associated bays.

g. Transmission system for evacuation of power from Fatehgarh/Barmer Complex as part of Rajasthan REZ Ph-IV (Part-4 :3.5 GW) [Fatehgarh/Barmer Complex]

Considering grant of connectivity to RE generators in Fatehgarh/Barmer complex as well as for evacuation of power beyond above complex, transmission scheme for evacuation of power from Fatehgarh/Barmer Complex as part of Rajasthan REZ Ph-IV (Part-4 :3.5GW) has been envisaged. The scheme shall also facilitate evacuation of additional RE power evacuation from Nagaur complex (2 GW) which will require some immediate transmission system requirement i.e. 400/220 kV ICTs and 220 kV line bays along with NR-WR inter regional corridors.

The transmission scheme was discussed and technically approved in the 71st NRPC meeting held on 29.01.2024 and recommended to NCT. Further, reactive compensation of some of the lines was modified and the same was approved in 49th TCC/72nd NRPC meeting held on 29th-30th March 2024.

Scheme was deliberated in 27th CMETS-NR meeting held on 10.01,24. In the meeting RVPN stated that they do not have any drawl requirement in future from proposed Merta-2 S/s. In view of envisaged RE potential in Nagaur distt., space provision to be kept for 220kV scope i.e. 400/220kV ICTs., 220 kV line bays for drawl & 220kV Sectionalization bay for RE injection

Considering grant of connectivity to RE generators in Fatehgarh/Barmer complex as well as for evacuation of power beyond above complex, Transmission system for evacuation of power from Fatehgarh/Barmer Complex as part of Rajasthan REZ Ph-IV (Part-4 :3.5 GW) [Fatehgarh/Barmer Complex] was agreed in Joint study meetings (28.12.23 & 09.01.24) as well as in 27th CMETS-NR meeting held on 10.01.24. The scheme shall also facilitate evacuation of additional power evacuation from Nagaur complex (2GW) for which some immediate transmission system requirement from Nagaur complex and Inter regional corridors requirement shall be assessed

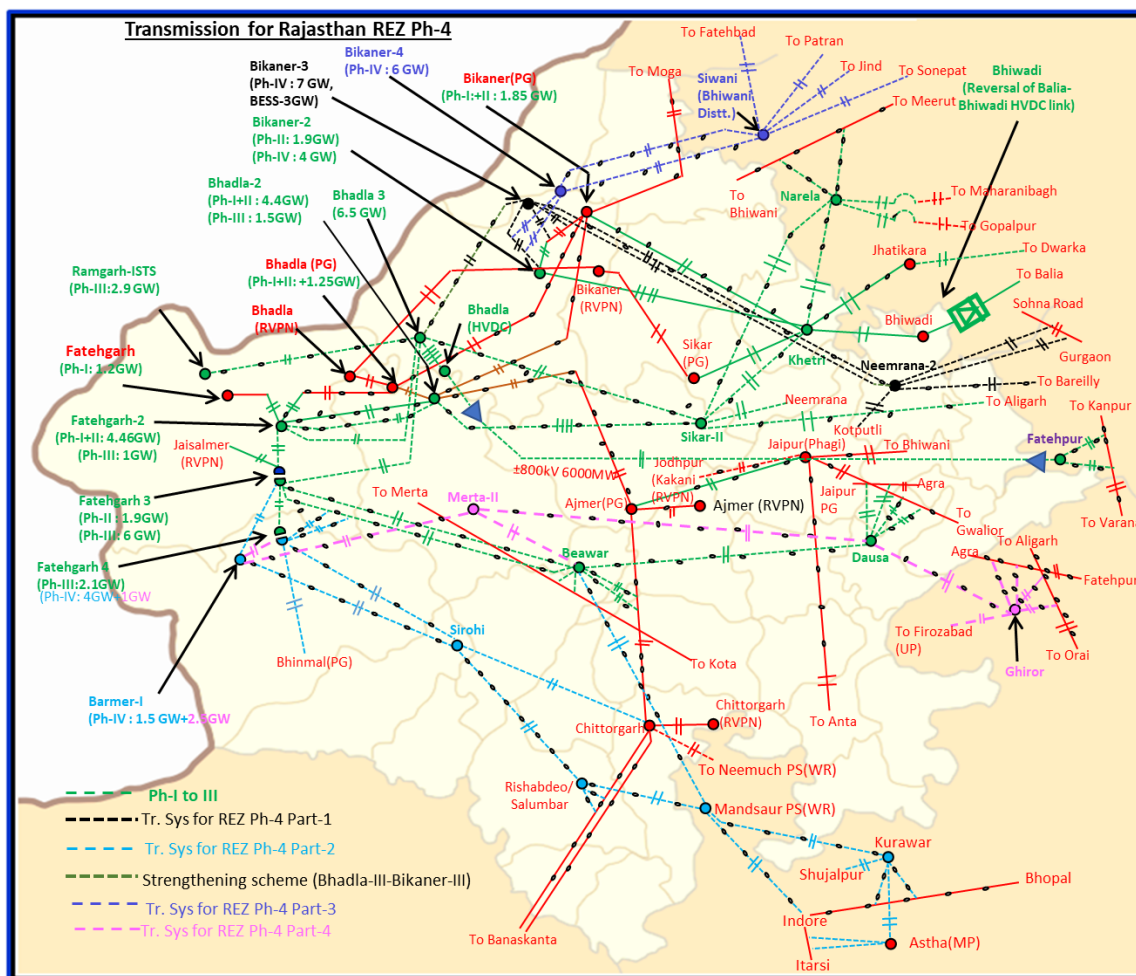

Figure 4-6: Transmission system for Rajasthan REZ Ph-IV (Part-4 :3.5GW) [Fatehgarh/Barmer complex]

NCT (in 19th NCT held on 29/04/2024) recommended implementation of the Transmission system for evacuation of power from Rajasthan REZ Ph-IV (Part-4: 3.5 GW): Part A and Part B to be undertaken under TBCB.

Transmission system for evacuation of power from Rajasthan REZ Ph-IV (Part-4: 3.5 GW): Part A

Summary of the scheme is given below:

SI No.	Name of the scheme and tentative implementation timeframe	Estimated Cost (Crores)	Remarks
1	Transmission system for evacuation of power from Rajasthan REZ Ph-IV (Part-4: 3.5 GW): Part A Tentative implementation timeframe: 24 months from the date of SPV transfer	5,845.93	Recommended under TBCB route with RECPDCL as BPC

Detailed scope of the scheme:

Sl. No.	Description of Transmission Element	Scope of work (Type of Substation/Conductor capacity/km/no. of bays etc.)
1	Augmentation with 765/400 kV, 2x1500 MVA Transformer (4th & 5th) at Barmer-I PS	<ul style="list-style-type: none"> • 765/400 kV 1500 MVA ICTs- 2 nos. • 765 kV ICT bays-2 no. • 400 kV ICT bays- 2 no.
2	Augmentation of 5x500 MVA (5 th to 9 th), 400/220 kV ICTs at Barmer-I PS	<ul style="list-style-type: none"> • 400/220 kV 500 MVA ICTs- 5 nos. • 400 kV ICT bays-5 nos. • 220 kV ICT bays- 5 nos.
3	220kV line bays (6 nos.) for RE connectivity at Barmer-I PS	<ul style="list-style-type: none"> • 220 kV line bays- 6 nos.
4	400kV Sectionalizer bay (1 set), 220kV Sectionalizer bay (1 set) along with 220kV BC (1 nos.) and 220 kV TBC (1 nos.) at Barmer-I PS	<ul style="list-style-type: none"> • 400 kV Sectionalier bay: 1 set • 220 kV Sectionalizer bay: 1 set • 220 kV BC (1 nos.) bay and 220 kV TBC (1 nos.) bay
5	STATCOM (2x±300MVA _r) along with MSC (4x125 MVA _r) & MSR (2x125 MVA _r) along with 2 nos. 400 kV bays at Barmer-I PS	<ul style="list-style-type: none"> • STATCOM (2x±300MVA_r) MSC (4x125 MVA_r) & MSR (2x125 MVA_r) • 400kV bays at Barmer-I PS – 2 nos.
6	Fatehgarh-IV PS (Sec-2) – Barmer-I PS 400kV D/c line (Quad)	<p>Line Length ~45 km (Quad)</p> <ul style="list-style-type: none"> • 400 kV line bays at Fatehgarh-IV PS (Sec-2) – 2 nos. • 400 kV line bays at Barmer-I PS – 2 nos.
7	<p>Establishment of 765/400kV, 2x1500 MVA S/s at suitable location near Ghiror (Distt. Mainpuri) along with 2x240 MVA_r (765kV) & 2x125 MVA_r (420kV) bus reactor at Ghiror S/s (UP)</p> <p>Future provisions at Ghiror S/s:</p> <p>Space for</p> <ul style="list-style-type: none"> • 765/400kV ICTs along with bays- 4 	<p>Ghiror S/s- AIS</p> <ul style="list-style-type: none"> • 765/400 kV 1500 MVA ICTs- 2 nos. (7x500 MVA including one spare unit) • 765 kV ICT bays-2 no. • 400 kV ICT bays- 2 no. • 765kV line bays : 8 nos. (for LILO of Aligarh(PG)-Orai(PG) D/c, LILO of Agra (PG) –

Sl. No.	Description of Transmission Element	Scope of work (Type of Substation/Conductor capacity/km/no. of bays etc.)
	<ul style="list-style-type: none"> • 765 kV line bays along with switchable line reactors – 6 • 765kV Bus Reactor along with bay: 1 nos. • 400 kV line bays along with switchable line reactor –6 • 400 kV Bus Reactor along with bays: 1 no. • 400kV Sectionalizer bay: 1 set • 400/220kV ICT along with bays -4 nos. • 220 kV line bays for drawl -6 nos. • 220kV Sectionalizer bay: 1 set • 220 kV BC (2 nos.) bays and 220 kV TBC (2 nos.) bays • STATCOM (2x±300MVA, 4x125MVA MSC, 2x125MVA MSR) along with 400kV bays (2 nos.) 	<p>Fatehpur(PG) S/c & 765kV interconnection with Dausa S/s)</p> <ul style="list-style-type: none"> • 400kV line bays : 2 nos. (for 400kV interconnection with Firozabad (UPPTCL) S/s) • 240 MVA Bus Reactor-2 no. (7x80 MVA, including one spare unit) • 765 kV Bus reactor bays-2 no. • 125 MVA Bus Reactor-2 nos. • 400 kV Bus reactor bays- 2 no. • 110MVA spare reactor unit (single phase)-1 no.
8	Dausa - Ghiror 765 kV D/c line along with 330MVA switchable line reactor at Ghiror end and 240 MVA switchable line reactor at Dausa end for each circuit of Dausa - Ghiror 765 kV D/c line	<p>Line Length -305 km</p> <ul style="list-style-type: none"> • 765 kV, 240 MVA switchable line reactors at Dausa S/s end– 2 nos. • 765 kV, 330 MVA switchable line reactors at Ghiror S/s S/s end– 2 nos. • Switching equipment for 765kV, 240 MVA switchable line reactors at Dausa S/s end – 2 nos. • Switching equipment for 765kV, 330 MVA switchable line reactors at Ghiror S/s end – 2 nos.
9	LILO of both ckt of 765 kV Aligarh (PG) -Orai (PG) D/c line at Ghiror S/s along with 240 MVA switchable line reactor for each circuit at Ghiror S/s end of 765 kV Ghiror -Orai (PG) D/c line	<p>Length -15km (LILO length)</p> <ul style="list-style-type: none"> • 765 kV, 240 MVA switchable line reactors at Ghiror S/s end– 2 nos. • Switching equipment for 765kV, 240 MVA switchable line reactors at Ghiror S/s end – 2 nos.

Sl. No.	Description of Transmission Element	Scope of work (Type of Substation/Conductor capacity/km/no. of bays etc.)
10	LILO of one ckt of 765kV Agra (PG) – Fatehpur (PG) 2xS/c line at Ghiror along with 240 MVAR switchable line reactor at Ghiror end of 765 kV Ghiror - Fatehpur (PG) line	Length -30km (LILO length) <ul style="list-style-type: none"> • 765 kV, 240 MVAR switchable line reactors at Ghiror S/s end– 1 no. • Switching equipment for 765kV, 240 MVAR switchable line reactor at Ghiror S/s end – 1 no.
11	400kV Ghiror-Firozabad (UPPTCL) D/c line (Quad)	Line Length ~50 km (Quad)
12	2 nos. 765kV line bays at Dausa S/s	• 765 kV line bays at Dausa S/s – 2 nos
13	2 nos. 400kV line bays at Firozabad (UPPTCL) S/s	• 400 kV line bays at Firozabad (UPPTCL) S/s – 2 nos

Note:

- The line lengths mentioned above are approximate as the exact length shall be obtained after the detailed survey
- Developer of Fatehgarh-IV PS (Sec-2) & Barmer-I PS shall provide space for 2 Nos. of 400 kV line bays each at Fatehgarh-IV PS (Sec-2) & Barmer-I PS
- Developer of Barmer-I PS shall provide space for 765/400 kV ICTs(2x1500 MVA), 400/220 kV ICTs (5x500 MVA), 220 kV line bays(6 Nos.), 400 kV Sectionalizer bay (1 set), 220 kV Sectionalizer bay (1 set), 220kV BC (1 Nos.), 220 kV TBC (1 Nos.), STATCOM & associated 2 Nos. of 400 kV bays at Barmer-I PS
- UPPTCL shall provide space for 2 Nos. of 400 kV line bays at Firozabad S/s
- POWERGRID shall provide space for 2 Nos. of 765 kV line bays at Dausa S/s along with space for 2 Nos. of 240 MVAR switchable line reactors

Transmission system for evacuation of power from Rajasthan REZ Ph-IV (Part-4: 3.5 GW):
Part B

Summary of the scheme is given below:

SI No.	Name of the scheme and tentative implementation timeframe	Estimated Cost (₹ Crores)	Remarks

1.	Transmission system for evacuation of power from Rajasthan REZ Ph-IV (Part-4 :3.5 GW): Part B Tentative implementation timeframe : 24 months from the date of SPV transfer	6,394.94 Cr	Recommended under TBCB route with RECPDCL as BPC
----	---	-------------	--

Detailed scope of the scheme:

Sl. No.	Description of Transmission Element	Scope of work (Type of Substation/Conductor capacity/km/no. of bays etc.)
1	<p>➤ Establishment of 765/400 kV, 2x1500 MVA S/s at suitable location near Merta (Merta-II Substation) along with 2x240 MVA (765kV) & 2x125 MVA (420kV) bus reactor at Merta-II S/s</p> <p>Future provisions at Merta-II S/s:</p> <p>Space for</p> <ul style="list-style-type: none"> • 765/400kV ICTs along with bays- 4 • 765 kV line bays along with switchable line reactors – 8 • 765kV Bus Reactor along with bay: 1 nos. • 400 kV line bays along with switchable line reactor –8 nos. • 400 kV line bays – 2 nos. • 400 kV Bus Reactor along with bays: 1 no. • 400kV Sectionalizer bay: 2 sets • 400/220kV ICTs along with bays -4 nos. • 220 kV line bays for RE injection -5 nos. • 220kV Sectionalizer bay: 2 set • 220 kV BC (2 nos.) bays and 220 kV TBC (2 nos.) bays 	<p>Merta-II S/s -AIS</p> <ul style="list-style-type: none"> • 765/400 kV 1500 MVA ICTs- 2 nos. (7x500 MVA including one spare unit) • 400/220 kV 500 MVA ICTs -2 Nos. • 765 kV ICT bays-2 no. • 400 kV ICT bays- 4 no. • 220 kV ICT bays- 2 no. • 765kV line bays: 4 nos. (for 765kV interconnection with Dausa S/s & Barmer-I PS) • 400kV line bays: 2 nos. (for 400kV interconnection with Beawar S/s) • 240 MVA Bus Reactor-2 no. (7x80 MVA, including one spare unit) • 765 kV Bus reactor bays-2 no. • 125 MVA Bus Reactor-2 nos. • 400 kV Bus reactor bays- 2 no. • 220 kV line bays: 3 nos. (for RE connectivity) • 220 kV BC (1 nos.) bay and 220 kV TBC (1 nos.) bay • 110MVA spare reactor unit (single phase)-1 no.

Sl. No.	Description of Transmission Element	Scope of work (Type of Substation/Conductor capacity/km/no. of bays etc.)
	<ul style="list-style-type: none"> STATCOM (2x±300MVA_r, 4x125MVA_r MSC, 2x125MVA_r MSR) along with 400kV bays (2 nos.) 	
2	Barmer-I PS – Merta-II 765 kV D/c line along with 330 MVA _r switchable line reactor for each circuit at each end of Barmer-I PS – Merta-II 765 kV D/c line	Line Length -345 km <ul style="list-style-type: none"> 765 kV, 330 MVA_r switchable line reactors at Barmer-I PS end– 2 nos. 765 kV, 330 MVA_r switchable line reactors at Merta-II S/s end– 2 nos. Switching equipment for 765kV, 330 MVA_r switchable line reactors at Barmer-I PS end – 2 nos. Switching equipment for 765kV, 330 MVA_r switchable line reactors at Merta-II S/s end – 2 nos. 110MVA_r spare reactor unit at Barmer-I PS (single phase)-1 no.
3	Merta-II – Beawar 400 kV D/c line (Quad)	Line Length ~55 km (Quad)
4	Merta-II – Dausa 765 kV D/c line along with 240 MVA _r switchable line reactor for each circuit at each end of Merta-II – Dausa 765kV D/c line line	Line Length -250 km <ul style="list-style-type: none"> 765 kV, 240 MVA_r switchable line reactors at Dausa S/s end– 2 nos. 765 kV, 240 MVA_r switchable line reactors at Merta-II S/s end– 2 nos. Switching equipment for 765kV, 240 MVA_r switchable line reactors at Dausa S/s end – 2 nos. Switching equipment for 765kV, 240 MVA_r switchable line reactors at Merta-II PS end – 2 nos.
5	2 nos. 765kV line bays each at Barmer-I PS & Dausa S/s	<ul style="list-style-type: none"> 765 kV line bays at Barmer-I PS – 2 nos. 765 kV line bays at Dausa S/s – 2 nos
6	2 nos. 400kV line bays at Beawar S/s	<ul style="list-style-type: none"> 400 kV line bays at Beawar S/s – 2 nos.

Note:

- The line lengths mentioned above are approximate as the exact length shall be obtained after the detailed survey
- Developer of Barmer-I PS shall provide space for 2 Nos. of 765 kV line bays along with space for 2 Nos. of 330 MVAR switchable line reactor and space for spare reactor unit (110 MVAR) at Barmer -I PS
- Sterlite shall provide space for 2 Nos. of 400 kV line bays at Beawar S/s
- POWERGRID shall provide space for 2 Nos. of 765 kV line bays at Dausa S/s along with space for 2 Nos. of 240 MVAR switchable line reactor

h. Transmission system for evacuation of power from Rajasthan REZ Ph-V (Part-1 :4 GW) [Sirohi/Nagaur] Complex, Transmission scheme

In 30th CMETS -NR meeting held on 18/06/2024 It was deliberated that Renewable Energy Zones (REZs) were identified by MNRE/SECI with a total capacity of 181.5 GW for likely benefits by the year 2030 in eight states, which includes 75GW REZ potential in Rajasthan comprising of 15 GW Wind and 60 GW Solar. In this regard a Committee on Transmission Planning for RE was constituted by MOP for planning of the requisite Inter State Transmission System required for the targeted RE capacity by 2030 for which a Comprehensive transmission plan for evacuation of 75GW RE potential from Rajasthan was evolved.

Large no. of applications from new RE generators have been received for connectivity at Sirohi and Nagaur/Merta complexes. Therefore, a transmission system for evacuation of power from Rajasthan REZ Ph-V (Part-1 :4 GW) [Sirohi/Nagaur] Complex, is evolved. It was discussed that Merta S/s is under bidding as part of “Transmission system for evacuation of power from Rajasthan REZ Ph-IV (Part-4: 3.5 GW): Part B” scheme which was recommended to be implemented through TBCB route with RECPDCL as BPC in 19th NCT meeting held on 29.04.2024. MoP vide Gazette ID no. CG-DL-E-14062024-254705 dated 14.06.24 notified the above transmission scheme. It was decided that transmission system for immediate evacuation of power from Merta-II PS as part of transmission system for evacuation of power from Rajasthan REZ Ph-V (Part-1 :4 GW) [Sirohi/Nagaur] Complex [approx Rs 197 Cr] shall be included in the scope of Transmission system for evacuation of power from Rajasthan REZ Ph-IV (Part-4: 3.5 GW): Part B. Therefore, following scope may be incorporated in the mentioned scheme i.e. Transmission system for evacuation of power from Rajasthan REZ Ph-IV (Part-4: 3.5 GW): Part B

- 3x500 MVA, 400/220 kV ICTs at Merta-II S/s along with associated transformer bays
- 4 Nos. 220 kV line bays at Merta-II S/s for RE interconnection
- 220 kV Sectionalizer bay (1 set) along with 220 kV BC (1 No.) bay and 220 kV TBC (1 No.) bay at Merta-II S/s

The revised scope of above scheme (Rajasthan REZ Ph-IV (Part-4: 3.5 GW): Part B) will be as mentioned below:

S.No.	Earlier Scope of Transmission Scheme	Revised Scope of Transmission Scheme
1	<p>Establishment of 765/400 kV, 2x1500 MVA S/s at suitable location near Merta (Merta-II Substation) along with 2x240 MVA (765 kV) & 2x125 MVA (420 kV) bus reactor at Merta-II S/s</p> <p>Merta-II S/s -AIS</p> <ul style="list-style-type: none"> • 765/400 kV 1500 MVA ICTs- 2 Nos. (7x500 MVA including one spare unit) • 400/220 kV 500 MVA ICTs -2 Nos. • 765 kV ICT bays-2 Nos. • 400 kV ICT bays- 4 Nos. • 220 kV ICT bays- 2 Nos. • 765kV line bays: 4 Nos. (for 765kV interconnection with Dausa S/s & Barmer-I PS) • 400 kV line bays: 2 Nos. (for 400 kV interconnection with Beawar S/s) • 240 MVA Bus Reactor-2 Nos. (7x80 MVA, including one spare unit) • 765 kV Bus reactor bays-2 Nos. • 125 MVA Bus Reactor-2 Nos. • 400 kV Bus reactor bays- 2 Nos. • 220 kV line bays: 3 Nos. (for RE connectivity) • 220 kV BC (1 No.) bay and 220 kV TBC (1 Nos.) bay • 110 MVA spare reactor unit (single phase)-1 Nos. <p>Future provisions at Merta-II S/s: Space for</p> <ul style="list-style-type: none"> • 765/400kV ICTs along with bays- 4 • 765 kV line bays along with switchable line reactors – 8 	<p>Establishment of 765/400 kV, 2x1500 MVA S/s at suitable location near Merta (Merta-II Substation) along with 2x240 MVA (765 kV) & 2x125 MVA (420 kV) bus reactor at Merta-II S/s</p> <p>Merta-II S/s -AIS</p> <ul style="list-style-type: none"> • 765/400 kV 1500 MVA ICTs- 2 Nos. (7x500 MVA including one spare unit) • 400/220 kV 500 MVA ICTs -5 Nos. • 765 kV ICT bays-2 Nos. • 400 kV ICT bays- 7 Nos. • 220 kV ICT bays- 5 Nos. • 765kV line bays: 4 Nos. (for 765kV interconnection with Dausa S/s & Barmer-I PS) • 400 kV line bays: 2 Nos. (for 400 kV interconnection with Beawar S/s) • 240 MVA Bus Reactor-2 Nos. (7x80 MVA, including one spare unit) • 765 kV Bus reactor bays-2 Nos. • 125 MVA Bus Reactor-2 Nos. • 400 kV Bus reactor bays- 2 Nos. • 220 kV line bays: 7 Nos. (for RE connectivity) • 220 kV BC (2 No.) bay and 220 kV TBC (2 Nos.) bay • 110 MVA spare reactor unit (single phase)-1 Nos. • 220 kV sectionalizer bay (1 set) <p>Future provisions at Merta-II S/s:</p>

S.No.	Earlier Scope of Transmission Scheme	Revised Scope of Transmission Scheme
	<ul style="list-style-type: none"> • 765kV Bus Reactor along with bay: 1 Nos. • 400 kV line bays along with switchable line reactor –8 Nos. • 400 kV line bays – 2 Nos. • 400 kV Bus Reactor along with bays: 1 Nos. • 400kV Sectionalizer bay: 2 sets • 400/220kV ICTs along with bays -4 Nos. • 220 kV line bays for RE injection -5 Nos. • 220 kV Sectionalizer bay: 2 set • 220 kV BC (2 Nos.) bays and 220 kV TBC (2 Nos.) bays • STATCOM (2x±300MVA_r, 4x125MVA_r MSC, 2x125MVA_r MSR) along with 400kV bays (2 Nos.) 	<p>Space for</p> <ul style="list-style-type: none"> • 765/400kV ICTs along with bays- 4 • 765 kV line bays along with switchable line reactors – 8 • 765kV Bus Reactor along with bay: 1 Nos. • 400 kV line bays along with switchable line reactor –8 Nos. • 400 kV line bays – 2 Nos. • 400 kV Bus Reactor along with bays: 1 Nos. • 400kV Sectionalizer bay: 2 sets • 400/220kV ICTs along with bays -1 No. • 220 kV line bays for RE injection -1 No. • 220 kV Sectionalizer bay: 1 set • 220 kV BC (1 No.) bays and 220 kV TBC (1 No.) bays • STATCOM (2x±300MVA_r, 4x125MVA_r MSC, 2x125MVA_r MSR) along with 400kV bays (2 Nos.)
2	Barmer-I PS – Merta-II 765 kV D/c line along with 330 MVA _r switchable line reactor for each circuit at each end of Barmer-I PS – Merta-II 765 kV D/c line	No Change
3	Merta-II – Beawar 400 kV D/c line (Quad)	
4	Merta-II – Dausa 765 kV D/c line along with 240 MVA _r switchable line reactor for each circuit at each end of Merta-II – Dausa 765kV D/c line line	
5	2 Nos. 765kV line bays each at Barmer-I PS & Dausa S/s	
6.	2 Nos. 400kV line bays at Beawar S/s	

Further, for Sirohi and Nagaur complexes, scheme for Transmission system for evacuation of power from Rajasthan REZ Ph-V (Part-1: 4 GW) [Sirohi/Nagaur] Complex was recommended by NCT (21st NCT meeting held on 06/08/24) under TBCB with above mentioned changes in the scheme.

Summary of the scheme is given below:

SI No.	Name of the scheme and tentative implementation timeframe	Estimated Cost (₹ Crore)	Remarks
1.	Transmission system for evacuation of power from Rajasthan REZ Ph-V (Part-1: 4 GW) [Sirohi/Nagaur] Complex Implementation timeframe: 24 months from allocation of project	₹5027.61 Cr (NR Portion : ₹2897.44 Cr WR Portion : ₹2130.21 Cr)	Recommended under TBCB route with RECPDCL as BPC

Detailed scope of the scheme is given below:

Sl. No.	Description of Transmission Element	Scope of work (Type of Substation/Conductor capacity/km/no. of bays etc.)
Transmission system for immediate Evacuation of Power from Sirohi S/s (2 GW)		
1	5x500 MVA, 400/220 kV ICTs at Sirohi S/s along with transformer bays	<ul style="list-style-type: none"> 400/220 kV 500 MVA ICTs- 5 Nos. 400 kV ICT bays-5 Nos. 220 kV ICT bays- 5 Nos.
2	6 Nos. 220 kV line bays at Sirohi S/s for RE interconnection	<ul style="list-style-type: none"> 220 kV line bays – 6 Nos.
3	220 kV Sectionalizer bay (1 set) along with 220 kV BC (2 Nos.) bay and 220 kV TBC (2 Nos.) bay at Sirohi S/s	<ul style="list-style-type: none"> 220 kV Sectionalizer bay (1 set) 220 kV BC (2 Nos.) bay and 220 kV TBC (2 Nos.) bay
Transmission system for Common Evacuation of Power from Sirohi PS (2 GW) & Merta-II PS (2 GW)		
4	Sirohi – Mandasaur PS 765KV D/c line along with 240 MVAR switchable line reactor at Sirohi end and 330 MVAR switchable line reactor at Mandasaur PS end for each circuit of Sirohi – Mandasaur PS 765KV D/c line	<p>Line Length -320 km (Approx)</p> <ul style="list-style-type: none"> 765 kV line bays at Sirohi S/s – 2 Nos. 765 kV line bays at Mandasaur PS – 2 Nos. 765 kV, 240 MVAR switchable line reactors at Sirohi S/s end– 2 Nos. 765 kV, 330 MVAR switchable line reactors at Mandasaur PS end– 2 Nos. Switching equipment for 765kV, 240 MVAR switchable line reactors at Sirohi S/s end – 2 Nos.

		<ul style="list-style-type: none"> • Switching equipment for 765kV, 330 MVAR switchable line reactors at Mandsaur PS end – 2 Nos.
5	Mandsaur PS – Khandwa (New) 765kV D/c line along with 240 MVAR switchable line reactor for each circuit at each end of Mandsaur PS – Khandwa (New) 765kV D/c line	<p>Line Length ~260 km (Approx)</p> <ul style="list-style-type: none"> • 765 kV line bays at Mandsaur PS – 2 Nos. • 765 kV line bays at Khandwa (New) – 2 Nos. • 765 kV, 240 MVAR switchable line reactors at Mandsaur PS end– 2 Nos. • 765 kV, 240 MVAR switchable line reactors at Khandwa (New) end– 2 Nos. • Switching equipment for 765kV, 240 MVAR switchable line reactors at Mandsaur PS end – 2 Nos. • Switching equipment for 765kV, 240 MVAR switchable line reactors at Khandwa (New) end – 2 Nos.

• Developer of Sirohi S/s shall provide space for 2 Nos. of 765 kV line bays, 400/220 kV ICTs, 220 kV line bays. 220 kV Sectionalizer bay along with 220 kV BC bay and 220 kV TBC bay, switchable line reactors (along with switching equipment) at Sirohi S/s as per the scope

• Developer of Mandsaur PS shall provide space for 4 Nos. of 765 kV line bays, switchable line reactors (along with switching equipment) at Mandsaur PS

• M/s Sterlite shall provide space for 2 Nos. of 765 kV line bays switchable line reactor (along with switching equipment) at Khandwa S/s

• The line lengths mentioned above are approximate as the exact length shall be obtained after the detailed survey

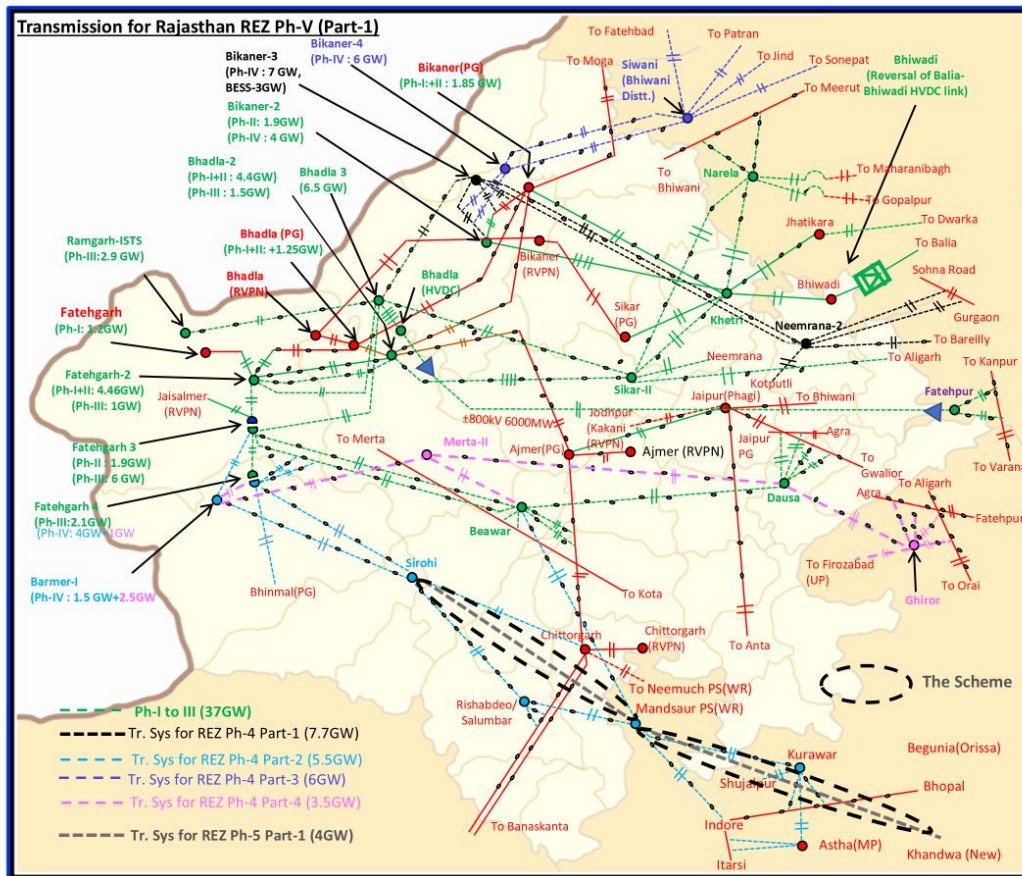

Figure 4-7: Transmission system for evacuation of power from Rajasthan REZ Ph-V (Part-1: 4 GW) [Sirohi/Nagaur] Complex

i. Implementation of 1 no. of 400 kV line bay at 765/400/220kV Bhadla-III PS for interconnection of M/s ReNew Solar (Shakti Six) Private Limited (450+550MW) RE project

In the 23rd CMETS-NR meeting held on 29.08.2023, it was decided to grant connectivity under GNA with one no. of 400 kV bay under ISTS scope at Bhadla-III PS for interconnection of RE Project of M/s ReNew Solar (Shakti Six) Private Limited (450+550 MW).

M/s ReNew Solar (Shakti Six) Private Limited sought the start date of connectivity from 31.12.25 for 550 MW & 31.03.2025 for 450 MW. However, considering the schedule of common transmission as well as bay implementation schedule, connectivity under GNA was granted to M/s ReNew Solar (Shakti Six) Private Limited with the interim start date of 30.09.25. M/s ReNew Solar (Shakti Six) Private Limited has also submitted the Con-BGs.

M/s Renew vide letter 10.05.24 informed the revised commissioning schedule of their solar power projects (550MW+450MW) to 31.03.26 and requested to change the start date of connectivity & bay implementation date for both the applications (550+450 MW) to 31st March 2026 in the final grant of Connectivity.

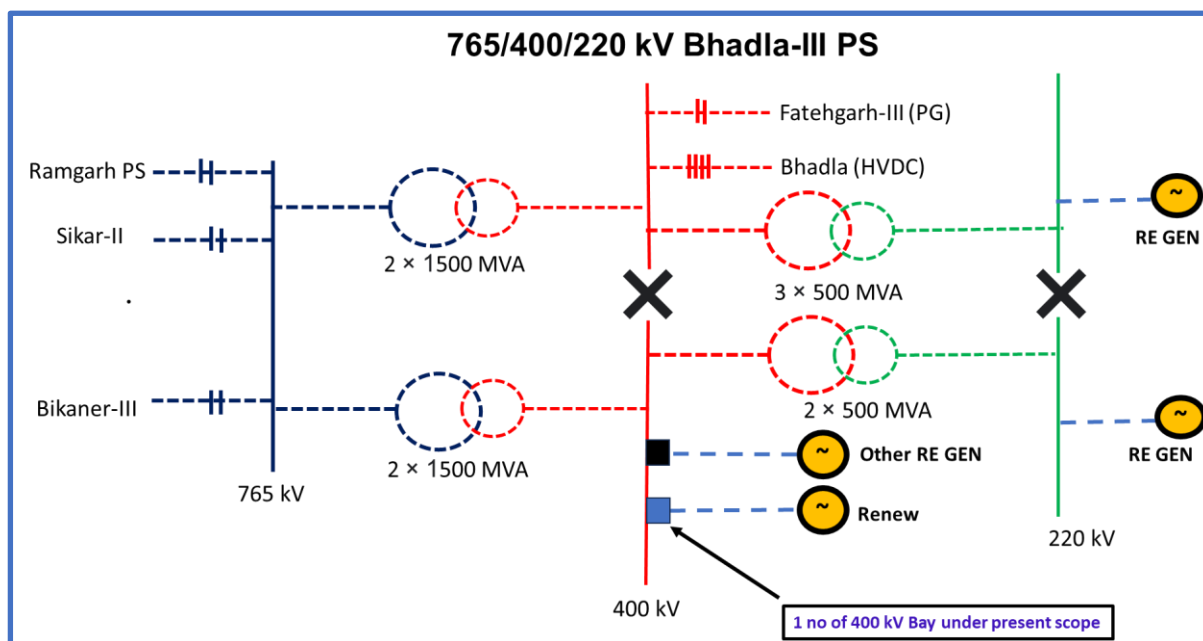

Figure 4-9: Schematic of 765/400/220 kV Bhadla-III PS

The scheme is under implementation with following details:

Project Name - Implementation of 1 no. of 400 kV line bay at 765/400/220kV Bhadla-III PS for interconnection of M/s ReNew Solar (Shakti Six) Pvt. Ltd.

Sl. No.	Scope of the Transmission Scheme	Capacity/km	Implementation timeframe
1	1 no. of 400 kV line bay at 765/400/220 kV Bhadla-III PS for interconnection of RE project (M/s ReNew Solar (Shakti Six) Private Limited)	400 kV line bay – 1 no.	31.03.26
Total Estimated Cost:			INR 13.37 Crore

This scheme was awarded to POWERGRID through RTM mode vide CTU OM dated 14.06.2024 with an implementation time frame of 31.03.2026.

j. Augmentation of Transformation Capacity at 765/400/220kV Bikaner PS in Rajasthan by 400/220kV, 1x500 MVA ICT (4th)

In the 8th CMETS-NR meeting held on 30.06.22 and 56th NRPC meeting held on 29.07.22, agenda for Implementation of "N-1" contingency at RE pooling substations in NR was deliberated. In the meeting ICTs at RE pooling stations incl. 400/220kV, 500MVA (4th) ICT at Bikaner PS was agreed to be taken up for implementation with timeframe of 15 months from the date of allocation of project or evacuation requirement beyond 1000 MW at 220kV level of Bikaner PS whichever is later.

Further agenda for implementation of "N-1" contingency at RE pooling substations in NR was deliberated in 73rd NRPC meeting held on 21.05.24. In the meeting it was mentioned that under Connectivity Regulations 2009, Connectivity & LTA were different products. However, subsequent to notification of GNA regulations, connectivity has become a single merged product which is granted along with equal quantum of GNA.

At present, Bikaner (PG) S/s has 400/220 kV transformation capacity of 1000 MVA(2x500MVA). Further, 3rd 500MVA ICT is currently under implementation and is expected to be commissioned by Jun'24. At present, 935 MW of RE is already interconnected at Bikaner PS at 220 kV level and additional connectivity of 300 MW (70+105MW+125MW) is also granted to M/s Shikhar Surya (One) Pvt. Ltd. and applicant have completed the necessary transition requirement of connectivity of 300MW from Connectivity regulations 2009 to GNA Regulations 2022.

Considering above, total connectivity of 1235 MW is granted at 220kV level of Bikaner (PG). Therefore, there is requirement of 4th, 500MVA ICT at Bikaner (PG) to meet N-1 compliance beyond 1000 MW at 220kV level.

In the 73rd NRPC meeting, It was also deliberated that considering project timelines of ICT augmentation, implementation timeframe for above augmentation may be kept as 18 months instead of 15 months due to practical issues. In view of the deliberations, Augmentation with 400/220 kV, 500 MVA (4th) ICT at Bikaner PS along with associated transformer bays was agreed in 73rd NRPC meeting held on 21.05.24.

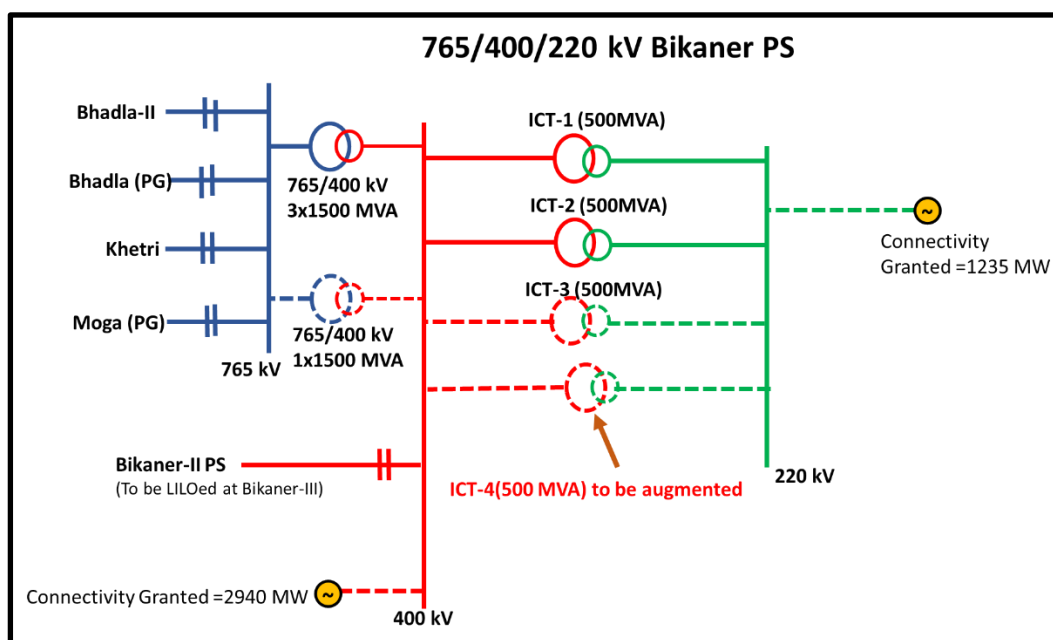

Figure 4-10: Schematic of 765/400/220 kV Bikaner PS

The scheme is under implementation with following details:

Project Name - Augmentation of Transformation Capacity at 765/400/220kV Bikaner PS in Rajasthan by 400/220kV, 1x500 MVA ICT (4th)

Sl. No.	Scope of the Transmission Scheme	Capacity/km	Implementation timeframe
1	Augmentation of Transformation Capacity at 765/400/220kV Bikaner PS in Rajasthan by 400/220kV, 1x500 MVA ICT (4th) along with associated transformer bays	<ul style="list-style-type: none"> ➤ 500 MVA, 400/220 kV ICT- 1 no. ➤ 400 kV ICT bay – 1 no. ➤ 220 kV ICT bay – 1 no 	18 months from the date of issuance of OM by CTUIL i.e. 18.01.2026
Total Estimated Cost:			INR 57.59 Crore

This scheme was awarded to POWERGRID through RTM mode vide CTU OM dated 18.07.2024 with an implementation time frame of 18 months from the date of issuance of OM by CTUIL i.e. 18.01.2026

k. Augmentation with 400/220 kV, 1x500 MVA Transformer (11th) at Fatehgarh-2 PS

Augmentation with 400/220 kV, 1x500 MVA, Transformer (10th) at Fatehgarh-2 PS was agreed as part of “transmission system for evacuation of power from REZ in Rajasthan (20 GW) under Phase-III Part J” in 5th NCT meeting held on 25.08.2021 and 02.09.2021. In that meeting, it was also agreed that Implementation of above ICT shall be taken up after LTA of 4490 MW at 220 kV level of Fatehgarh-2 PS. Subsequently, based on NCT recommendation, MoP vide OM dated 01.12.2021 awarded above transmission scheme to CTUIL with implementation timeframe of 15 months from MoP OM or evacuation requirement beyond 4490 MW at 220 kV level of Fatehgarh-2 PS, whichever is later. Further, CTUIL vide letter dated 02.12.2021 allocated above scheme to POWERGRID based on MoP OM dated 01.12.2021.

220 kV level of Fatehgarh-2 PS is implemented in two sections i.e. Section-I & II. Further, both the 220kV sections are implemented in geographically opposite sides (way apart from each other and not electrically connected) as per GA and layout of pooling station. However, 400 kV & 765 kV bus remained common for both the yards. At present, RE Connectivity of 2490MW under GNA is granted at Section-I and 1970MW is granted at Section-II, thus making total connectivity at Fatehgarh-2 PS as 4460MW which is less than 4490 MW.

Subsequently, Manual on Transmission Planning Criteria was published by CEA in Mar’23. As per the above, ‘N-1’ reliability criteria may be considered for ICTs at the ISTS / STU pooling stations for renewable energy based generation of more than 1000 MW. As both the 220kV sections of Fatehgarh-2 PS are electrically isolated and have more than 1000MW RE connectivity in respective sections, ‘N-1’ criteria to be fulfilled at both the sections. Keeping above in view, 1x500MVA, 400/220kV ICT (6th) at Section-I was awarded which is under implementation (Jul’24).

Considering requirement of 400/220kV ICT (in Fatehgarh-II Section-II) for N-1 compliance in Fatehgarh-II PS (Section-II), it was proposed that 1x500 MVA, 400/220 kV ICT (now 11th ICT) at Fatehgarh-II PS as approved by MoP vide OM dated 01.12.2021 based on recommendation in 5th NCT meeting may be taken up for implementation with 18 month implementation schedule considering present timeline for ICT augmentation (instead of earlier 15 months) to fulfil ‘N-1’ criteria as per CEA Manual on Transmission Planning Criteria, 2023.

After deliberations, NCT (in 20th NCT meeting dated 25/06/2024) approved modification in the transmission scheme for “Augmentation with 400/220 kV, 1x500 MVA Transformer (10th) at Fatehgarh-2 PS” as mentioned below so that same can be taken up for implementation:

Earlier (as per MOP OM dated 01.12.21)	Amendment
<p>Augmentation with 400/220 kV, 1x500 MVA Transformer (10th) at Fatehgarh-2 PS</p> <ul style="list-style-type: none"> • 400/220 kV 500 MVA ICT:1 no • 400 kV ICT bays – 1 Nos. • 220 kV ICT bays - 1 Nos. <p>Implementation Timeframe- 15 months from MOP OM or evacuation requirement beyond 4490 MW at 220 kV level of Fatehgarh-2, whichever is later</p>	<p>Augmentation with 400/220 kV, 1x500 MVA Transformer (11th) at Fatehgarh-II PS (5th ICT in Fatehgarh-II section-II)</p> <ul style="list-style-type: none"> • 400/220 kV 500 MVA ICT:1 no • 400 kV ICT bays – 1 no. • 220 kV ICT bays - 1 no. <p>Implementation Timeframe- 18 months [for N-1 compliance in Fatehgarh-II PS (Section-II)]</p>

4.4.2 Punjab

(a) Augmentation of Transformation Capacity at 400/220kV Malerkotla(PG) S/s in Punjab by 400/220kV, 1x500MVA ICT (4th)

The proposal was deliberated in the 21st CMETS-NR meeting held on 31.07.23. In the meeting it was stated that from the loading pattern of Malerkotla ICTs (2x315+1x500 MVA), it was observed that Loading of ICTs have reached maximum of about 830 MW (on 1130 MVA) in past one year (Jun’22-Aug’22) in Paddy season of Punjab and reaching to N-1 limit level for peak Loading of ICTs (~830 MW). Further from rolling plan studies (2027-28) also, ICT loading (~880MW) is breaching N-1 limits increasing in Paddy season load of Punjab.

POWERGRID vide mail dated 28.06.23 confirmed the space availability of 400/220kV transformer (4th 1x500MVA) along with transformer bays at 400/220kV Malerkotla S/s (existing ICTs 2x315+1X500MVA). It was informed that 400kV side bay equipment shall be

GIS type and 220kV side shall be routed to PSTCL yard through 220kV GIB/Cable whereas 220kV side ICT bay space may be confirmed by PSTCL.

CTU vide mail 17.07.24 requested PSTCL to provide their observations on requirement of ICT at Malerkotla S/s w.r.t. present and future demand. It was also requested PSTCL to provide details regarding space availability for 220kV side ICT bay at Malerkotla Substation.

In the CMETS-NR meeting, PSTCL stated that space is available and same was communicated to POWERGRID with 3-4 options along with most suitable option. CTU requested to provide the SLD, which was shared by PSTCL on 31.07.23. PSTCL enquired about techno economics of GIB/Cable. POWERGRID informed that based upon RoW issue and hindrance, the selection could be made, however, cable would be cheaper than GIB if both the options are feasible. PSTCL confirmed the requirement of ICT at Malerkotla S/s w.r.t. present and future demand. GRID India stated that ICT augmentation at Malerkotla may be considered based on PSTCL requirement, however, recently augmentation has been done at Patiala and this may affect ICT loadings at Malerkotla too. PSTCL again confirmed that ICT shall be required in paddy season and ICT loadings have been breached at Malerkotla for some instances in present Peddy season also despite of Patiala ICT augmentation. PSTCL also stated that as ICT implementation may also take about 2 years, same may be approved now so that ICT would be available by 2025.

CTU stated that this ICT augmentation may require 21 months for implementation as it involves 400kV side bay equipment of GIS type. Regarding 220kV side bay along with GIB/cable, PSTCL requested that 220kV works may be implemented in ISTS by same implementing agency assigned for transformer augmentation for better coordination, however, if 220kV work is assigned to PSTCL, 21 months time is sufficient for 220kV bay implementation. CEA also agreed for augmentation requirement at Malerkotla S/s. In view of that it was decided that ICT augmentation along with 400kV & 220kV side bay equipment is to be implemented in ISTS.

POWERGRID vide mail 11.09.23 to PSTCL informed that POWERGRID is planning to lay 220kV cable for ICT-4 ,for connection with PSTCL's 220kV bus at PSTCL Malerkotla. For this purpose, POWERGRID also sent proposed cable route to PSTCL for vetting purpose. PSTCL vide mail 14.09.23 informed POWERGRID that Proposed Cable route Draft Proposed Cable route (received through POWERGRID mail) is not feasible. PSTCL requested POWERGRID to provide the feasible cable route for further necessary action.

Subsequently, a committee comprising members of CTUIL & POWERGRID has visited the 400/220 kV Malerkotla S/s on 10.02.2024 and explored the options of installing 4th ICT at Malerkotla S/s, including the bays at Malerkotla PSTCL S/s. Following was concluded in the site visit report :

- For 220 kV connection between 400 kV and 220 kV side of Malerkotla S/s, underground cable seems feasible.
- Space is available for 4th ICT (400/220 kV, 1x500 MVA) at Malerkotla (PG) S/s including the 400 kV GIS bays

- Sufficient space is available in 220 kV (PSTCL) Malerkotla Switchyard for accommodating one no. 220 kV (AIS) bay. PSTCL has proposed 220 kV AIS Bay at location 3 for connecting the 4th ICT.

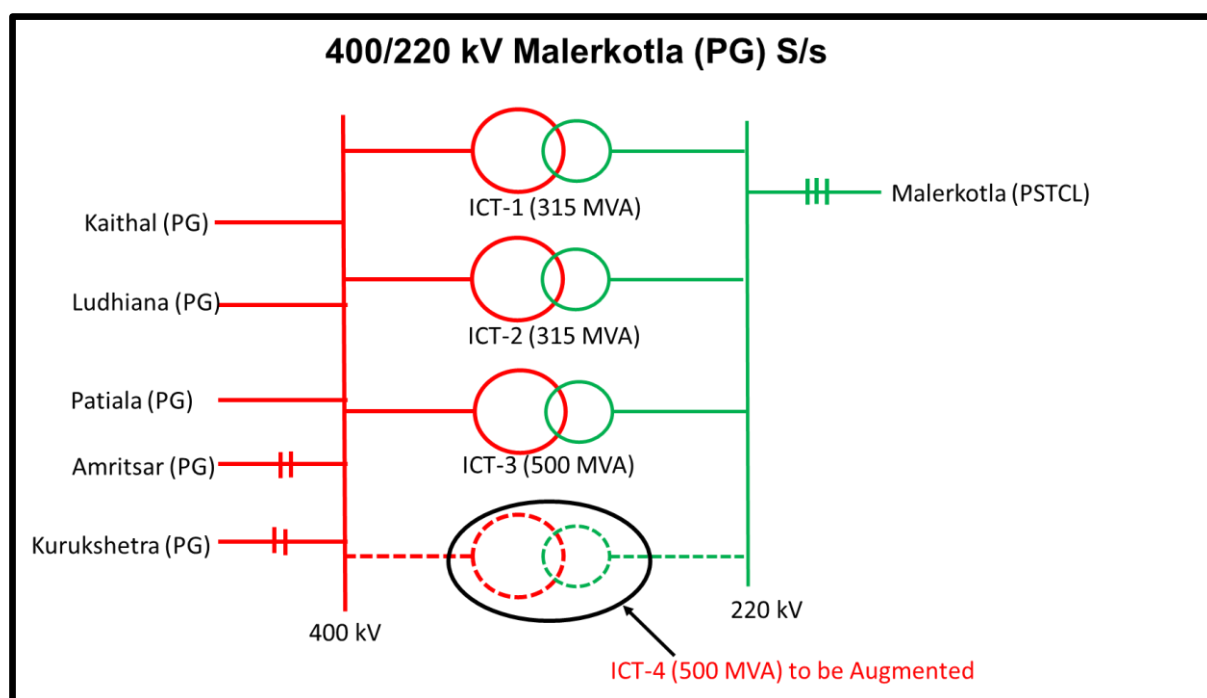

Figure 4-11: Schematic of 765/400/220kV Hisar (PG) S/s

The scheme is under implementation with following details:

Project Name - Augmentation of Transformation Capacity at 400/220kV Malerkotla(PG) S/s in Punjab by 400/220kV, 1x500MVA ICT (4th)

Sl. No.	Scope of the Transmission Scheme	Capacity/km	Implementation timeframe
1	<p>Augmentation of Transformation Capacity at 400/220kV Malerkotla(PG) S/s in Punjab by 400/220kV, 1x500MVA ICT (4th) along with associated transformer bays*</p> <p>*incl. extension of 400kV & 220 kV side of ICT through Cable/GIB. 400kV side bay equipment shall be GIS type</p>	<ul style="list-style-type: none"> ➤ 500 MVA, 400/220 kV ICT - 1 no. ➤ 400 kV ICT bays (GIS) – 1 no. (in new diameter with 1 no. additional bay for diameter completion) (refer note a) ➤ 220 kV ICT bay – 1 no. ➤ 400kV GIS duct (1ph) – 100m approx. 	<p>21 months from the date of issuance of OM by CTUIL i.e. 14.03.2026 (refer note b)</p>

		<ul style="list-style-type: none"> ➤ 220kV Cable (1ph) – 3200m approx. ➤ 220 kV Cable Termination Kit: 8 nos. 	
Total Estimated Cost:			INR 88 Crore

Note:

(b) In view of GIS substation, one complete 400kV diameter with three Circuit Breakers (one and half switching scheme) shall be implemented at 400kV level for interconnection of ICT in one 400kV bay. Utilization of another 400kV bay of the diameter shall be identified in future

(c) Best efforts shall be carried out to implement the transmission scheme within 18 months from the issuance of OM by CTUIL i.e. 14.12.2025.

(d) PSTCL to provide space to ISTS licensee for implementation of 1 no. 220kV ICT bay (AIS) at 220kV Malerkotla(PSTCL) switchyard for termination of the above 400/220kV, 1x500MVA ICT (4th) ICT at 220kV side.

This scheme was awarded to POWERGRID through RTM mode vide CTU OM dated 14.06.2024 with an implementation time frame of 21 months from the date of issuance of OM by CTUIL i.e. 14.03.2026 (refer note b).

4.4.3 Jammu & Kashmir

(a)Transmission scheme for evacuation of power from Ratle HEP (850 MW) & Kiru HEP (624 MW)

Ratle HEP (850 MW) has applied for connectivity with ISTS. Accordingly a Comprehensive Transmission system for Ratle HEP has been identified. Recently CTU has received also connectivity application from Kiru HEP (624 MW) with commissioning schedule of Sep'26 (01.09.26) for which comprehensive Transmission system identified for Ratle HEP (commissioning progressively from 30.09.26) will be utilized along with some additional ICT augmentations, if required. Therefore, the scheme may be considered combindly for Ratle (850 MW) & Kiru HEP (624 MW).

Above, transmission scheme was agreed in the 26th CMETS-NR meeting held on 01.12.23 & reactive compensation was agreed in the 28th CMETS-NR meeting held on 27.03.24. Further scheme was also agreed in 49th TCC/72nd NRPC meeting held on 29th-30th Mar'24. Transmission System was agreed in 20th National Committee on Transmission (NCT) held on 25.06.2024.

After deliberations, NCT recommend/approved the transmission scheme for evacuation of power from Ratle (850 MW) & Kiru (624 MW) HEPs under {TBCB- Rs. 1213.87 Cr.; RTM- Rs. 195.67 Cr.} with the implementation time frame of 24 months.

Summary of the scheme is given below:

SI No.	Name of the scheme and tentative implementation timeframe	Estimated Cost (₹ Crores)	Remarks
1	Transmission scheme for evacuation of power from Ratle HEP (850 MW) & Kiru HEP (624 MW): Part-A Tentative implementation timeframe : 24 Months from the date of SPV transfer	1213.87	Recommended under TBCB with RECPDCL as BPC
2	Transmission scheme for evacuation of power from Ratle HEP (850 MW) & Kiru HEP (624 MW): Part-B Tentative implementation timeframe : 24 Months or matching with Transmission scheme for evacuation of power from Ratle HEP (850 MW) & Kiru HEP (624 MW) : PartA scheme whichever is later	195.67	Approved Under RTM

Detailed scope of the scheme is given below:

Transmission scheme for evacuation of power from Ratle HEP (850 MW) & Kiru HEP (624 MW): Part-A

Sl. No.	Description of Transmission Element	Scope of work (Type of Substation/Conductor capacity/km/no. of bays etc.)
1	LILO of 400 kV Kishenpur- Dulhasti line (Twin) at Kishtwar S/s along with associated bays at Kishtwar S/s	LILO Length- 3km • 400 kV Kishenpur - Kishtwar (LILO section) shall be on Twin HTLS (with minimum 2100 MVA capacity) configuration

Sl. No.	Description of Transmission Element	Scope of work (Type of Substation/Conductor capacity/km/no. of bays etc.)
		<ul style="list-style-type: none"> • 400 kV Dulhasti - Kishtwar (LILO section) shall be on Twin Zebra configuration • 400kV line bays at Kishtwar – 2 nos. (GIS) (line bays at Kishtwar S/s end shall be rated accordingly)
2	<p>400 kV Kishenpur-Samba D/c line (Quad)</p> <p>(only one circuit is to be terminated at Kishenpur utilizing 1 no. of 400kV vacated line bay at Kishenpur S/s (formed with bypassing of one ckt of 400kV Kishtwar – Kishenpur 400kV D/c line (Quad) at Kishenpur) while second circuit would be connected to bypassed circuit of 400kV Kishtwar – Kishenpur line (Quad))</p>	Length -36 km (Quad)
3	<p>Bypassing of one ckt of 400kV Kishtwar – Kishenpur 400kV D/c line (Quad) at Kishenpur and connecting it with one of the circuit of Kishenpur-Samba 400kV D/c line(Quad), thus forming 400kV Kishtwar - Samba (Quad) direct line (one ckt)</p>	
4	<p>1x80 MVar Switchable line reactor at Samba end of 400kV Kishtwar-Samba 400kV line-165km (Quad) [formed after bypassing of 400kV Kishtwar – Kishenpur line (Quad) at Kishenpur and connecting it with one of the circuit of Kishenpur-Samba 400kV D/c line(Quad))</p>	<ul style="list-style-type: none"> • 420 kV, 80 MVar switchable line reactors at Samba S/s end– 1 nos. • Switching equipment for 420kV, 80 MVar switchable line reactors at Samba S/s end – 1 no
5	<p>1x63 MVar Switchable line reactor on each ckt at Jalandhar end of Kishenpur– Jalandhar D/c direct line - 171km(Twin) (formed after bypassing both ckts of 400 kV Kishenpur – Samba D/c line (Twin) & 400 kV Samba – Jalandhar D/c line (Twin) at Samba and connecting</p>	<ul style="list-style-type: none"> • 420 kV, 63 MVar switchable line reactors at Jalandhar S/s end– 2 nos.

Sl. No.	Description of Transmission Element	Scope of work (Type of Substation/Conductor capacity/km/no. of bays etc.)
	them together to form Kishenpur– Jalandhar D/c direct line (Twin))	<ul style="list-style-type: none"> Switching equipment for 420kV, 63 MVAR switchable line reactors at Jalandhar S/s end – 2 no
6	400kV Samba- Jalandhar D/c line(Quad) (only one circuit is to be terminated at Jalandhar utilizing 1 no. of 400kV vacated line bay at Jalandhar S/s (formed with bypassing of 400kV Jalandhar – Nakodar line (Quad) at Jalandhar) while second circuit would be connected to bypassed circuit of Jalandhar –Nakodar 400kV line (Quad))	Line Length -145 km
7	1x80 MVAR Switchable line reactor at Samba end of Samba –Nakodar direct line (Quad) (187km) formed after bypassing of 400 kV Jalandhar – Nakodar line (Quad) at Jalandhar and connecting it with one of the circuit of Samba-Jalandhar 400 kV D/c line(Quad Moose), thus forming Samba –Nakodar line (Quad)	<ul style="list-style-type: none"> 420 kV, 80 MVAR switchable line reactors at Samba S/s end– 1 no. Switching equipment for 420kV, 80 MVAR switchable line reactors at Samba S/s end – 1 no.
8	Bypassing 400kV Jalandhar – Nakodar line (Quad) at Jalandhar and connecting it with one of the circuit of Samba-Jalandhar 400kV D/c line(Quad Moose), thus forming 400kV Samba –Nakodar (Quad) direct line	

Note:

- M/s Sterlite shall provide space for 2 Nos. of 400 kV line bays (GIS) at Kishtwar S/s
- M/s POWERGRID shall provide space for 1 no. 80 MVAR Switchable line reactor (along with switching equipment) at Samba end of 400 kV Kishtwar-Samba 400 kV line
- M/s POWERGRID shall provide space for 2 Nos. 63 MVAR Switchable line reactor (along with switching equipment) at Jalandhar end of Kishenpur– Jalandhar D/c direct line (on each ckt)
- M/s POWERGRID shall provide space for 1 no. 80 MVAR Switchable line reactor (along with switching equipment) at Samba end of Samba –Nakodar direct line

Transmission scheme for evacuation of power from Ratle HEP (850 MW) & Kiru (624 MW)
HEP : Part B

Sl. NO.	Description of Transmission Element	Scope of work (Type of Substation/Conductor capacity/km/no. of bays etc.)
1	Reconductoring of 400 kV Kishenpur-Kishtwar section (up to LILO point) with Twin HTLS (minimum 2100 MVA capacity) (formed after LILO of Kishenpur-Dulhasti line at Kishtwar S/s) along with bay upgradation works (2000 A to 3150 A) at Kishenpur end for above line.	Length – 120 km <ul style="list-style-type: none"> 400 kV Bay upgradation work- 1 no. bay at Kishenpur end
2	Bypassing both ckts of 400 kV Kishenpur – Samba D/c line (Twin) & 400 kV Samba – Jalandhar D/c line (Twin) at Samba and connecting them together to form 400 kV Kishenpur– Jalandhar D/c direct line (Twin) (4 Nos. of vacated 400 kV line bays at Samba S/s will be utilized for 400 kV Kishenpur-Samba D/c line (Quad) & 400 kV Samba- Jalandhar D/c line(Quad),	Length -0.5 km (Twin)
3	Bays upgradation works (2000A to 3150A) at Samba end (4 Nos. bays vacated after bypassing of Kishenpur – Samba D/c line (Twin) & 400 kV Samba – Jalandhar D/c line (Twin))	400 kV Bay upgradation works- 4 Nos. bays
4	Redundant Communication System for Dulhasti (NHPC) & Kishtwar (Sterlite) stations by installing OPGW on 400 kV Kishenpur-Kishtwar S/c line alongwith reconductoring work and FOTE at Dulhasti & Kishenpur.	Length – 120 km

Note:

- TSP shall also install OPGW on bypass section to form link between 400 kV Kishenpur–Jalandhar

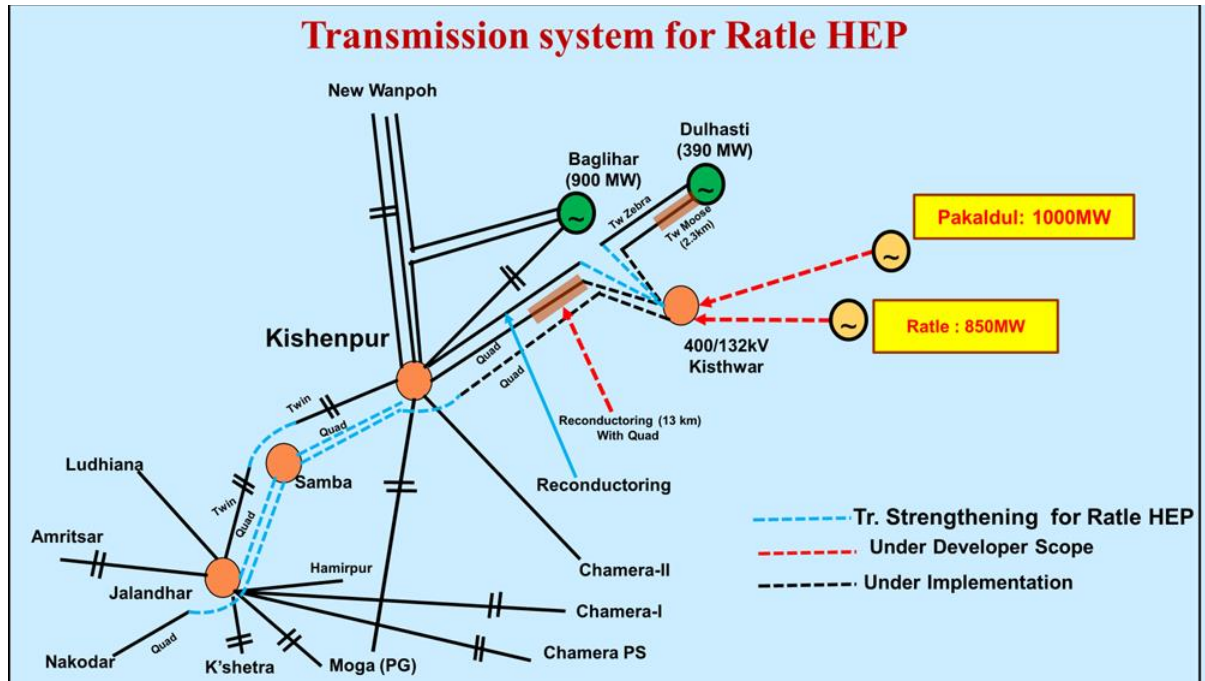

Figure 4-12: schematic for Transmission system for Ratle HEP

Chapter 5: Western Region

Due to geographical location, Western Region is connected to Northern, Southern and Eastern Regions through 765/400kV high-capacity corridors along with Back-to-Back HVDCs and Bi-Pole HVDC links. The thermal generating stations of Western Regions are predominantly concentrated in the coal rich states of Chhattisgarh, Eastern part of Maharashtra and Madhya Pradesh. Further, Gujarat, Maharashtra and Madhya Pradesh are RE rich states comprising of Solar & Wind capacity. Western part of Maharashtra, southern Gujarat and DD & DNH have high demand and less internal generation. Accordingly, power flows from Chhattisgarh/ Eastern Maharashtra through high-capacity corridors to Western part of Maharashtra, Southern Gujarat, DD & DNH. Based on the generation availability and demand, Western Region imports power from other regions during high RE scenarios whereas it exports power to other regions during evening peak and night off peak load.

5.1 Power Supply Scenario as on Aug'24

As on Aug'2024, total Installed Capacity (IC) of Western Region was about 149GW which constitute capacity from fossil sources (58% share) & balance (42% share) from non-fossil sources comprising of nuclear, renewable generation capacity including hydro and the peak demand met was about 75 GW. The share from non-fossil sources would further increase in future considering India's vision of generating 500 GW of non-fossil generation capacity by 2030. At present, there is no shortage of power supply in meeting these demands. State-wise breakup is summarised at **Table 5-1**.

Table 5-1: WR Installed Capacity and Demand met as on Aug'24

(All Fig in GW)

State	Generation							Grand Total	Peak Demand Met
	Fossil			Non-Fossil					
	Thermal	Gas	Total	Nuclear	Hydro	RES	Total		
Gujarat	18.6	6.6	25.1	1.0	0.8	27.1	28.9	54.1	25.6
MP	16.0	0.3	16.3	0.5	3.2	7.2	10.9	27.2	14.3
Maharashtra	25.4	3.5	28.9	1.1	3.3	15.6	20.0	48.9	28.9
Chhattisgarh	12.2	0.0	12.2	0.1	0.2	1.6	2.0	14.2	6.3
UT of DD & DNH	0.6	0.1	0.7	0.0	0.0	0.0	0.1	0.8	1.4
Goa	0.5	0.1	0.6	0.0	0.0	0.0	0.1	0.7	0.7
Central unallocated	2.8	0.2	3.0	0.4	0.0	0.0	0.4	3.5	--
WR	76.1	10.8	86.9	3.2	7.6	51.7	62.5	149.4	74.9

Source: CEA Monthly Report

5.2 Envisaged Power Supply Scenario by 2029-30

As per the 20th EPS, Western Region demand for 2029-30 timeframe is expected to increase to about 107 GW. The Installed capacity of Western Region is expected to be about 247GW. The state wise bifurcation of the same is given at **Table 5-2**.

Table 5-2: WR Installed Capacity and Peak Demand (2029-30)

(All Fig in GW)

State	Generation								Peak Demand	
	Fossil			Non-Fossil				ESS		Grand Total
	Thermal	Gas	Total	Nuclear	Hydro	RES	Total			
Gujarat	7.8	2.8	10.6	0.0	0.3	15.9	16.2	0.2	27.0	34
MP	6.9	0.0	6.9	0.0	3.1	4.2	7.3	0.0	14.2	25.6
Maharashtra	19.5	1.2	20.7	0.0	2.5	10.0	12.6	0.4	33.7	42
Chhattisgarh	1.6	0.0	1.6	0.0	0.1	0.2	0.4	0.0	1.9	8.8
DD	0.0	0.0	0.0	0.0	0.0	0.0	0.0	0.0	0.0	0.6
DNH	0.0	0.0	0.0	0.0	0.0	0.0	0.0	0.0	0.0	1.5
Goa	0.0	0.0	0.0	0.0	0.0	0.0	0.0	0.0	0.0	1.0
Central	22.2	3.3	25.5	3.2	0.0	95.5	98.8	7.5	131.7	--
IPP	35.5	2.8	38.2	0.0	0.0	0.0	0.0	0.0	38.2	--
WR	93.4	10.1	103.6	3.2	6.1	125.9	135.2	8.1	246.8	107

There is growth of around 32GW in the peak demand of Western Region from present timeframe to 2029-30. The state wise growth in demand for 2029-30 from present time-frame is tabulated below at **Table 5-3**:

Table 5-3: Increase in Peak Demand of Various States of WR

(All Fig in MW)

State	Peak Demand			
	Present (MW)	20th EPS (MW)	Increase in demand (MW)	CAGR
	2024-25 (Till Aug'2024)	2029-30		
Gujarat	25588	33964	8376	5.8%
MP	14309	25596	11287	12.3%
Maharashtra	27996	42042	14046	8.5%
Chhattisgarh	6347	8805	2458	6.8%
UT of DD & DNH	1353	2095	742	9.1%
Goa	803	1043	240	5.4%
WR	74993	107050	32117	7.4%

From the above data it is observed that the CAGR growth of peak demand is maximum for UT of DD & DNH (9.1%) and minimum for Goa (5.4%). The CAGR of demand of WR is about 7.4% which is more than the National Average of 6.1%.

In addition to above, bulk power demand of about 22000MW proposed to be directly connected to ISTS has also been considered from various upcoming green hydrogen/ green ammonia identified by MNRE, bulk consumers/distribution licensees. Major ISTS demand corresponding to the above loads in WR includes Navinal: 7500MW (3000MW Bulk Consumers & 4500MW GH/GA), Jamnagar (3700MW), 3000MW (Kandla: GH/GA) & various other bulk consumers/distribution licensees who have been granted GNA under GNA Regulations, 2022.

5.3 Load Generation Balance for 2029-30 timeframe

In Chapter-3, All India Load Generation Balance (LGB) for identified nine scenarios was prepared as per the methodology finalized in consultation with CTU, CEA and GRID INDIA. This section elaborates the Western Region Load Generation Balance (LGB) for 2029-30 timeframe. For Western Region also, three points on the daily load curve i.e. Solar max (afternoon), Peak load (evening) and Off-peak load (night) for three seasons viz. Monsoon (August), Summer (June) and Winter (February) have been considered.

Load generation balance has been prepared considering the generation despatch factors as mentioned at **Table 5-4** for the 9 scenarios. Further, thermal generators have been despatched as per the merit order.

Table 5-4: Western Region Generation Dispatch and Demand Factors

Scenario No & Name	Generation Dispatch Factors						Demand Factors
	Hydro	Nuclear	Solar	Wind	ESS	Gas	
1-Aug Solar Max	40%	80%	80%	55%	-100%	0%	98%
2-Aug Peak Load	70%	80%	0%	75%	60%	50%	87%
3-Aug Night Off Peak	40%	80%	0%	65%	40%	50%	66%
4-Jun Solar Max	40%	80%	85%	55%	-100%	0%	91%
5-Jun Peak Load	70%	80%	0%	75%	50%	50%	86%
6-Jun Night Off Peak	40%	80%	0%	65%	1%	50%	63%
7-Feb Solar Max	20%	80%	90%	10%	-100%	0%	93%
8-Feb Peak Load	40%	80%	0%	20%	100%	50%	85%
9-Feb Night Off Peak	20%	80%	0%	20%	40%	30%	69%

5.4 ISTS Network schemes evolved from Feb'24/Mar'24 to July'24

Various transmission systems have been planned and deliberated for implementation in the Consultation Meetings for Evolving Transmission Schemes in Western Region (CMETS-WR) and joint study meetings held from Feb'24/Mar'24 to July'24. These schemes have either been

approved or under various stages of approval. The details of the schemes have been summarized below at **Table 5-5:**

Table 5-5: Details of the schemes evolved in WR

Sl. No.	Name of Scheme	Time frame	Quantum (MW)	Type of Scheme*	Tentative cost (in Crores)
Gujarat					
1.	Transmission System for Evacuation of Power from potential renewable energy zone in Khavda area of Gujarat under Phase-V (8 GW): Part B	2026-27		RE	718
2.	ICT Augmentation at Bhuj PS for enabling RE injection	2027-28	500	RE	65.96
3.	Augmentation of transformation capacity at 765/400kV Lakadia S/s (WRSS XXI(A) Transco Ltd) in Gujarat – Part B	2026-27	2500	RE	636
4.	Augmentation of Transformation Capacity at 765/400/220kV Vadodara (GIS) S/s in Gujarat by 400/220kV, 1x500MVA ICT (3rd)	2025-26		SS	85.79
5.	Augmentation of transformation capacity at Banaskantha (Raghnesda) PS (GIS)	2027-28	500	RE	172
6.	Transmission system to provide redundant power supply to Dholera area	2025-26		SS	110
7.	Bays at Vataman S/s for Vataman – Saurashtra 765kV D/c line	2027-28		SS	70.96
8.	220kV line bays at Vapi-II S/s for LILO of 220 KV Chikhli – Vapi 220kV S/c line at Vapi-II	2026-27		SS	12
9.	Implementation of 220kV line bays at Bhuj PS for RE Interconnection	2026-27		RE	12.7
10.	Transmission System for evacuation of RE power from Raghnesda area of Gujarat – 3 GW under Phase-I	2027-28	3000	RE	1855
11.	Transmission System for evacuation of Green Hydrogen/Ammonia potential in Kandla area of Gujarat (Phase-I: 3 GW)	2027-28	3000	GH	2775
12.	Transmission System for supply of power to Green Hydrogen/Green Ammonia manufacturing potential in Mundra area of Gujarat under Phase-I: Part:B1	2027-28	3000	GH	2817
13.	Transmission System for supply of power to Green Hydrogen/Green Ammonia manufacturing potential in Mundra area of Gujarat under Phase-I: Part:B2	2027-28	7500	GH	6405
14.	Transmission System for Offshore Wind Zone Phase-1 (500 MW VGF off the coast of Gujarat for Subzone B3)	2028-29	500	RE	6900

Sl. No.	Name of Scheme	Time frame	Quantum (MW)	Type of Scheme*	Tentative cost (in Crores)
Maharashtra					
1.	Network Expansion scheme in Western Region to cater to Pumped storage potential near Talegaon (Pune)	2026-27	1500	RE	1663
Madhya Pradesh					
1.	Network Expansion Scheme in Vindhyaachal complex of Madhya Pradesh	2027-28	1600	Conv	5
2.	Transmission System for enabling RE interconnection at Mandsaur S/s	2029-30		RE	17.28
3.	Transmission System for enabling RE interconnection at Neemuch S/s	2025-26		RE	5.57
4.	Transmission system for Evacuation of Power from RE Projects in Neemuch (1000 MW) SEZ in Madhya Pradesh-Phase II	2027-28	1000	RE	2240
5.	Transmission system for Evacuation of Power from RE Projects in Rajgarh (1500 MW) SEZ in Madhya Pradesh-Phase III	2027-28	1500	RE	1079
6.	Transmission System for evacuation of power from Mahan Energen Limited Generating Station in Madhya Pradesh	2027-28	1200	Conv	558
Chhattisgarh					
1.	Transmission System for evacuation of power from Vedanta's Thermal Power Station (1200MW) in Sakti, Chhattisgarh	2025-26	1200	Conv	3.61
2.	400kV line bays at Champa for Interconnection of NTPC LARA STPP STAGE-II (1600MW) Project	2027-28	1600	Conv	18.57
3.	Scheme to control high voltages at Champa PS (on Bus Section-A, where Lara-I project is connected)	2027-28		SS	79.28
4.	Associated Transmission System for grant of Connectivity under GNA to Sipat STPS Stage-III (1x800MW)	2028-29	800	Conv	135.99
	Total	-	30,900	-	28,440

*RE – Renewable Energy; SS- System Strengthening; GH – Green Hydrogen; Conv – Conventional generators.

The schemes are detailed in the following sections.

5.4.1 Gujarat

- (a) Augmentation of transformation capacity at KPS1 (GIS) & KPS2 (GIS) & KPS3 (GIS) (Khavda Phase-V Part-B)

KPS1 Augmentation:

KPS1 (GIS) S/s with 3x1500MVA 765/400kV ICTs on Sec-I is already commissioned by M/s Adani Transmission Limited. Augmentation of transformation capacity by 1x1500MVA 765/400kV ICT (4th) on Sec-I is also being implemented by M/s ATL under RTM under Khavda Ph-IV Part-E1 scheme. Further, Sec-II of KPS1 is being established by M/s Megha Engineering & Infrastructures Limited with SCOD of Jan-25 with 4x1500MVA 765/400kV ICTs.

Further, applications for Connectivity for additional 810MW were received from M/s Adani Green Energy Ltd. Augmentation of transformation capacity is required to enable the injection of 810MW power at KPS1 maintaining N-1 criteria compliance. The scheme was discussed and approved in the 21st NCT meeting held on 06.08.2024 for implementation under TBCB route.

KPS2 Augmentation:

KPS2 S/s with 4x1500MVA, 765/400kV ICTs (2x1500 MVA on Sec-I & 2x1500 MVA on Sec-II) is under implementation by POWERGRID. 4x1500 MVA (2x1500 MVA on Sec-I & 2x1500 MVA on Sec-II) Addl. ICTs are also being implemented by POWERGRID (under TBCB) under Khavda Ph-IV Part-E2 scheme.

However, to enable the onward dispersal of power from KPS2 maintaining the N-1 criteria compliance, augmentation of transformation capacity by 1x1500MVA, 765/400kV ICT(9th) is proposed. The scheme was discussed and approved in the 21st NCT meeting held on 06.08.2024 for implementation under TBCB route.

The detailed scope of work for the above schemes is tabulated as below:

Sl. No.	Scope of the Transmission Scheme	Capacity /km
1.	<u>Khavda Ph-V Part-B1</u> Augmentation of transformation capacity at KPS1(GIS) by 1x1500 MVA, 765/400 kV ICT on Bus section-II (9th)	<ul style="list-style-type: none"> • 1500 MVA, 765/400 kV ICT – 1 Nos. • 765kV ICT bay – 1 Nos. on Bus section-II • 400 kV ICT bay – 1 Nos. (+1 Nos. (with Sw. LR bay provision) for Dia. Completion in GIS) on Bus section-II
2.	<u>Khavda Ph-V Part-B2</u> Augmentation of transformation capacity at KPS2(GIS) by 1x1500 MVA, 765/400 kV ICT on Bus section-I (9th)	<ul style="list-style-type: none"> • 1500 MVA, 765/400 kV ICT – 1 Nos. • 765 kV ICT bay – 1 Nos. (+1 Nos. (with Sw. LR bay provision) for Dia. Completion in GIS) on Bus section-I • 400 kV ICT bay – 1 Nos. (+1 Nos. (with Sw. LR bay provision) for Dia. Completion in GIS) on Bus section-I

Implementation time frame: 24 months from the date of award to implementing agency

Estimated cost: Rs. 466 Cr.

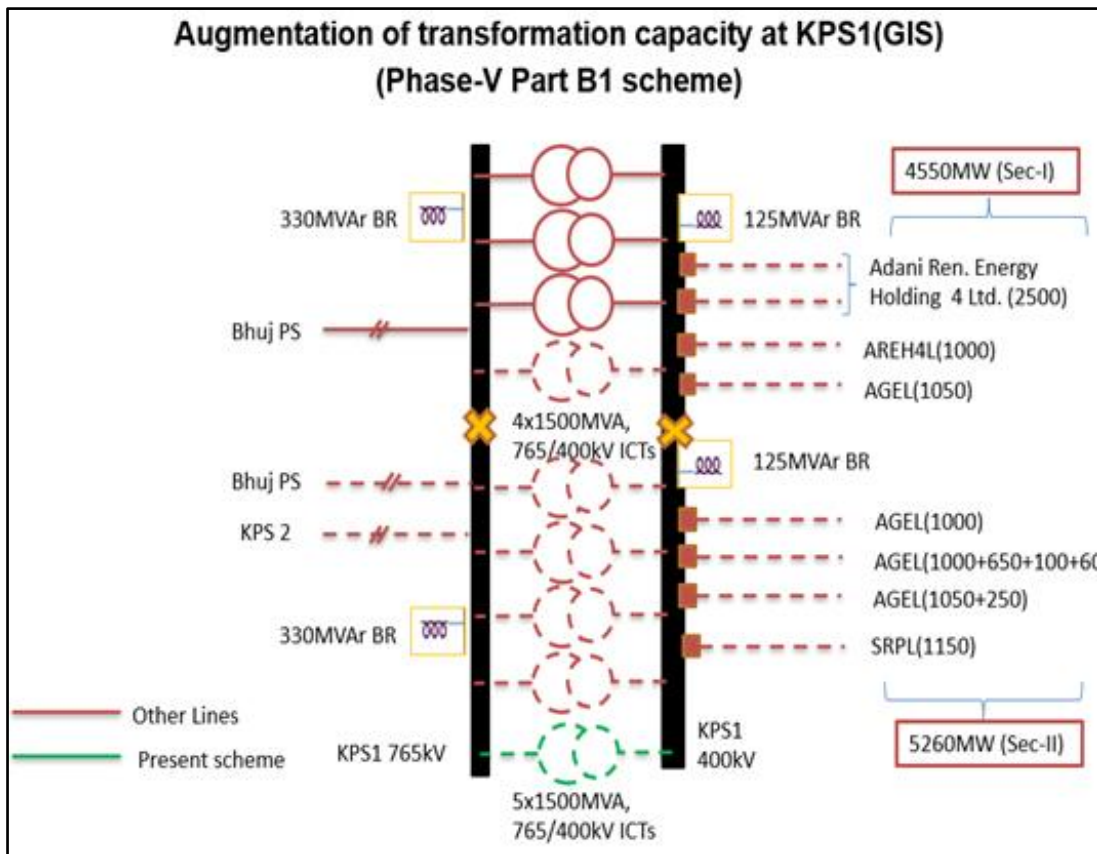

(a)

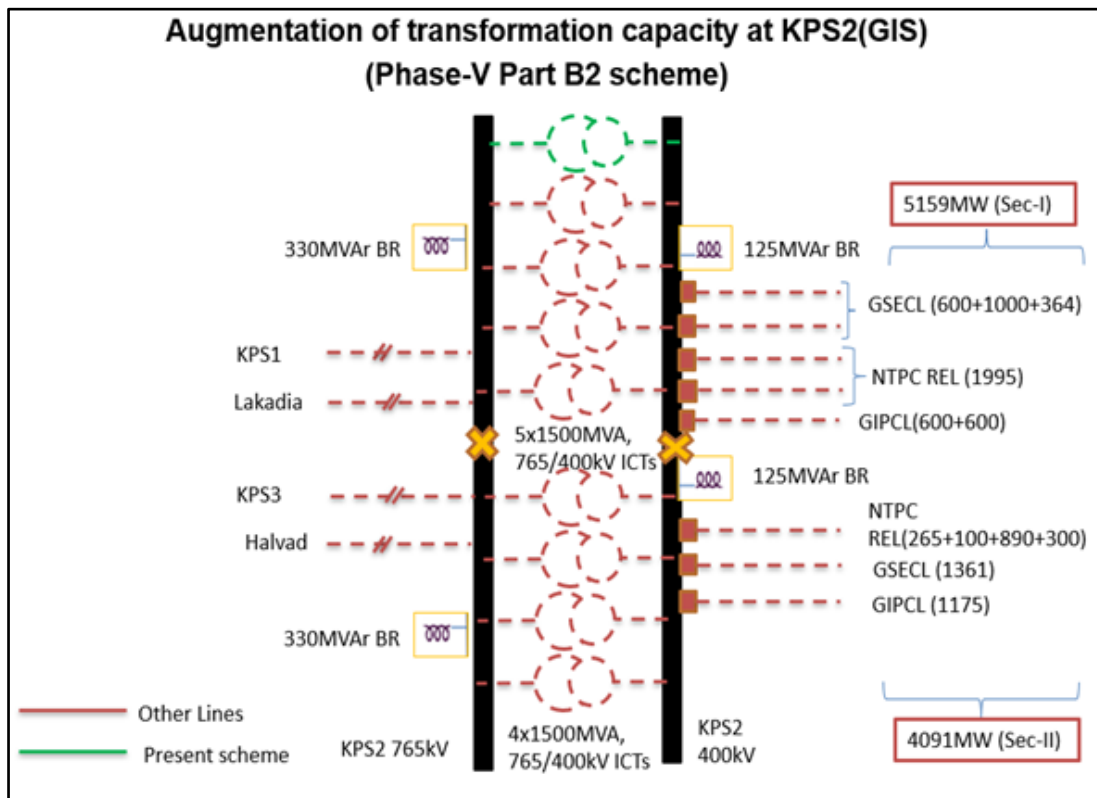

(b)

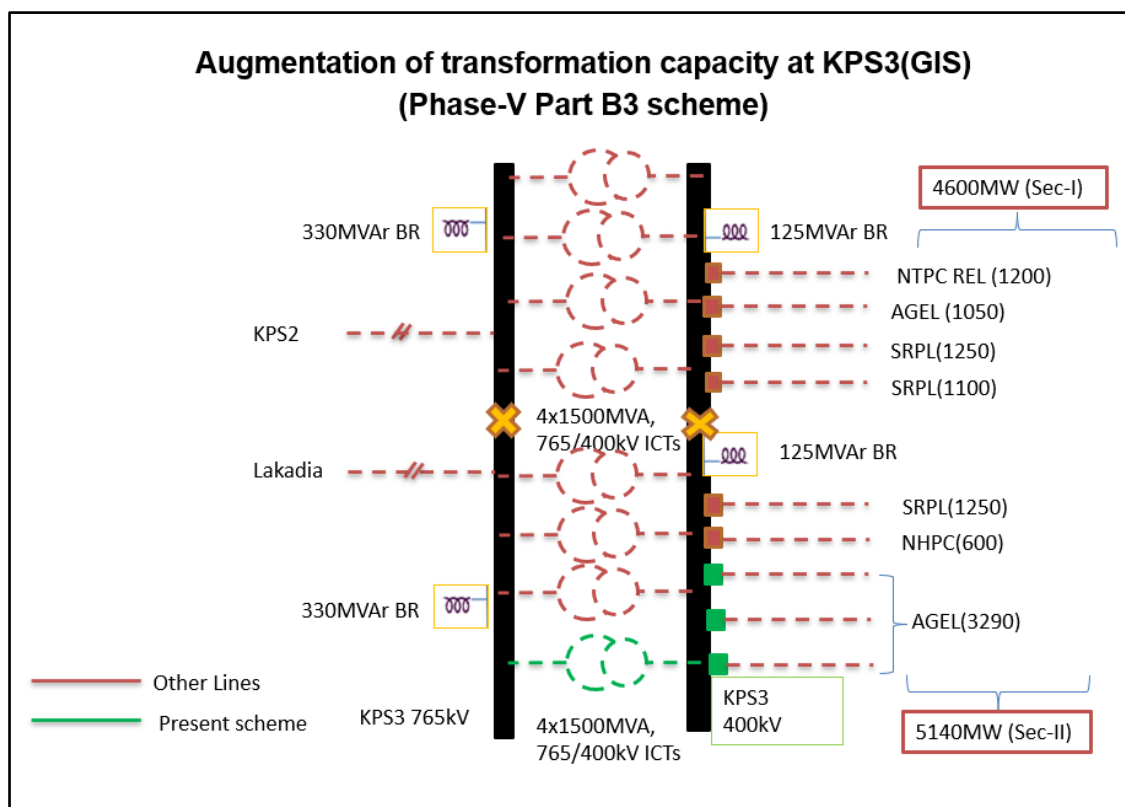

(c)

Figure 5-1: Schematics of KPS1 (a), KPS2 (b) & KPS3 (c) substations with the ICT augmentations

KPS3 Augmentation:

KPS3 S/s with 3x1500MVA, 765/400kV ICTs on Sec-I is under implementation by POWERGRID. Augmentation of transformation capacity by 1x1500MVA, 765/400kV ICT on Sec-I was also awarded to POWERGRID under RTM and is currently under implementation. Scheme for augmentation by 3x1500MVA, 765/400kV ICTs on Sec-II of KPS3 is under bidding under Khavda Ph-IV Part-A scheme.

Connectivity for 4600MW on Sec-I and 1850MW on Sec-II was granted at KPS3 against applications received so far. Further, applications for additional Connectivity for 3290MW (270MW on Sec-I & 3020MW on Sec-II) were received. Augmentation of transformation capacity by 1x1500MVA, 765/400kV ICT (8th) is required to enable the injection of additional 3290MW power from KPS3 considering the margins to be sufficient on commissioning of HVDC. The scheme was discussed and agreed for in the 31st CMETS-WR meeting held on 03.08.2024.

Sl. No.	Scope of the Transmission Scheme	Capacity /km
<u>Khavda Phase-V Part B3</u>		
1.	Augmentation of transformation capacity at KPS3(GIS) by 1x1500MVA, 765/400 kV ICT on Bus section-II (8 th)	<ul style="list-style-type: none"> • 765/400kV ICT – 1 • 765kV ICT bay – 1 on Bus section-II* • 400kV ICT bay – 1 on Bus section-II*

Sl. No.	Scope of the Transmission Scheme	Capacity /km
	<u>Khavda Phase-V Part B3</u>	
2.	3 nos. 400kV line bays on KPS3 400kV Bus Section-II for RE interconnection	• 400kV line bays – 3 nos.

*Bay(s) as may be required for completion of diameter (GIS) in one-and-half breaker scheme, shall also be executed by the TSP. Further, TSP of KPS3 shall provide space to carry out above augmentation works.

Implementation time frame: 24 months from the date of award to implementing agency

Estimated cost: Rs. 252 Cr.

(b) ICT Augmentation at Bhuj PS for enabling RE injection

Subsequent to the receipt of applications for Connectivity for 4000MW, Bhuj I PS was closed for further applications due to the non-availability of margins for RE injection considering N-1 criterion compliance. However, POWERGRID vide e-mail dated 12.06.2024, has confirmed the availability of space for another ICT. Hence augmentation of transformation capacity at Bhuj-I PS by 1x500MVA, 400/220kV ICT (10th) was planned to enable the injection of 500MW additional RE power. The scheme is currently under approval.

Detailed scope of work:

Sl. No.	Scope of the Transmission Scheme	Capacity/km
1.	Augmentation of Transformation capacity at Bhuj PS by 1x500MVA, 400/220kV ICT (10 th) with associated ICT bays	<ul style="list-style-type: none"> • 1x500MVA, 400/220kV ICT– 1 No. • 400kV ICT Bay: 1 No. (AIS) • 220kV ICT Bay: 1 No. (HGIS)

Note:

- POWERGRID vide e-mail dated 06.06.2024 & 12.06.2024 has informed that 400kV ICT Bay will be AIS (in dia. of bus reactor) and 220kV ICT bay will be Hybrid/MTS with connection of ICT with 220kV bay possible only through EHV Cables / GIB

Implementation timeframe: 18 months from award to implementing agency

Estimated cost: Rs. 65.96 Crs.

(c) Augmentation of transformation capacity at 765/400 kV Lakadia S/s (WRSS XXI (A) Transco Ltd) in Gujarat – Part B

765/400kV Lakadia S/s is existing and augmentation of transformation capacity by 2x500MVA 400/220kV ICTs are under implementation. Further, in view of the 2GW potential at Lakadia revived by MNRE vide letter dated 14.02.2024 & MoP letter dated 16.02.2024 and to enable the grant of Connectivity to the applicants in that area, the subject augmentation scheme is proposed.

The scheme was earlier discussed in parts (Part-B & Part-C) in the 17th & 18th NCT meetings wherein, considering the rapid pace of applications being received at Lakadia PS, it was

decided to install all remaining ICTs and 220kV bays at Lakadia PS in one go so as to minimize multiple implementation time-lines. Hence, the scheme was again deliberated and approved under TBCB in the 20th NCT meeting held on 25.06.2024 with implementation time frame as mentioned.

Detailed scope of work:

Sl. No.	Scope of the Transmission Scheme	Capacity /km	Time-frame
1.	Installation of 2x500 MVA, 400/220 kV ICTs (3 rd & 4 th) at Lakadia PS along with associated ICT bays	<ul style="list-style-type: none"> • 400/220 kV, 1x500 MVA ICT – 2 Nos. • 400 kV ICT bay – 2 Nos. • 220 kV ICT bay – 2 Nos. (220 kV bus section-I) 	18 months from date of allocation to implementing agency
2.	Implementation of 220 kV line bay at Lakadia PS for TEQ Green Power XVII Private Limited (TGPXVIPL: 300 MW)	<ul style="list-style-type: none"> • 220 kV line bay – 1 no. (220 kV bus section-I) 	18 months from date of allocation to implementing agency
3.	Implementation of 220 kV line bay at Lakadia PS for Arcelor Mittal Nippon Steel India Limited (AMNSIL: 350 MW)	<ul style="list-style-type: none"> • 220 kV line bay – 1 no. (220 kV bus section-I) 	18 months from date of allocation to implementing agency
4.	Implementation of 220 kV line bay at Lakadia PS for Renew Solar (Shakti Eight) Private Limited (RS(S8)PL: 200 MW)	<ul style="list-style-type: none"> • 220 kV line bay – 1 no. (220 kV bus section-I) 	30.09.2026 (as per start date requested by applicant)*
5.	Creation of New 220 kV Bus Section-II at Lakadia PS along with 220 kV Sectionaliser arrangement between 220 kV Bus sec-I & Sec-II	<ul style="list-style-type: none"> • 220 kV Bus Sectionaliser - 1 set • BC – 1 No. • TBC – 1 No. 	18 months from date of allocation to implementing agency
6.	Augmentation of transformation capacity at Lakadia PS by 4x500 MVA, 400/220 kV ICTs (5 th 6 th , 7 th & 8 th) terminated on new 220 kV Bus Section-II		
6a.	2x500MVA ICTs (5 th & 6 th)	<ul style="list-style-type: none"> • 500 MVA, 400/220 kV ICTs: 2 No. • 400 kV ICT bays: 2 Nos. • 220 kV ICT bays: 2 No. (New Bus Section-II) 	18 months from date of allocation to implementing agency
6b.	1x500MVA ICT (7 th)	<ul style="list-style-type: none"> • 500 MVA, 400/220 kV ICT: 1 No. • 400 kV ICT bay: 1 No. • 220 kV ICT bays: 1 No. (New Bus Section-II) 	31.12.2026
6c.	1x500MVA ICT (8 th)	<ul style="list-style-type: none"> • 500 MVA, 400/220 kV ICT: 1 No. • 400 kV ICT bay: 1 No. 	30.06.2027

Sl. No.	Scope of the Transmission Scheme	Capacity /km	Time-frame
		• 220 kV ICT bays: 1 No. (New Bus Section-II)	
7.	Implementation of 220 kV line bay at Lakadia PS for Juniper Green Energy Private Limited (JGEPL) (Appl. No. 2200000376: 300 MW)	• 220 kV line bay – 1 No. (New Bus Section-II)	30.06.2027 (as per start date requested by applicant)
8.	Implementation of 220 kV line bay at Lakadia PS for TEQ Green Power XVI Pvt. Ltd. (TGPXVIPL) (Appl. No. 2200000398: 76MW)	• 220 kV line bay – 1 No. (New Bus Section-II)	30.09.2026 (as per start date requested by applicant)*
9.	Implementation of 220 kV line bay at Lakadia PS for Ganeko Solar Pvt. Ltd. (GSPL) (Appl. No. 2200000458: 290 MW)	• 220 kV line bay – 1 No. (New Bus Section-II)	31.12.2026 (as per start date requested by applicant)*
10.	Implementation of 220 kV line bay at Lakadia PS for Juniper Green Energy Private Limited (JGEPL) (Appl. No. 2200000500: 150 MW)	• 220 kV line bay – 1 No. (New Bus Section-II)	31.03.2027 (as per start date requested by applicant)
11.	Implementation of 220 kV line bay at Lakadia PS for Serentica Renewables India Private Limited (SRIPL) (Appl. No. 2200000610: 200 MW)	• 220 kV line bay – 1 No. (New Bus Section-II)	30.06.2026*
12.	Implementation of 220 kV line bay at Lakadia PS for RDS Solar Park Private Limited (RDSSPPL) (Appl. No. 2200000639: 350 MW)	• 220 kV line bay – 1 No. (New Bus Section-II)	30.06.2026*
13.	Implementation of 220 kV line bay at Lakadia PS for Percentum Renewables Private Limited (PRPL) (Appl. No. 2200000673: 148 MW)	• 220 kV line bay – 1 No. (New Bus Section-II)	30.06.2026*
14.	Installation of 1x330 MVA 765 kV Bus Reactor (2nd) along-with associated bay	• 330 MVA, 765 kV Bus Reactor: 1 No. • 765 kV BR bay: 1 No.	18 months from date of allocation to implementing agency
15.	Augmentation of transformation capacity at Lakadia PS by 1x1500 MVA, 765/400 kV ICTs (3rd)	• 1500 MVA, 765/400 kV ICT: 1 No. • 400 kV ICT bay: 1 No. • 765 kV ICT bay: 1 No.	18 months from date of allocation to implementing agency

*subject to minimum schedule of 18 months from the date of allocation to implementing agency.

Note:

- TSP of Lakadia S/s (WRSS XXI(A) Transco Ltd.) shall provide space for above augmentation works at Lakadia S/s

Estimated Cost: Rs. 636 Crs.

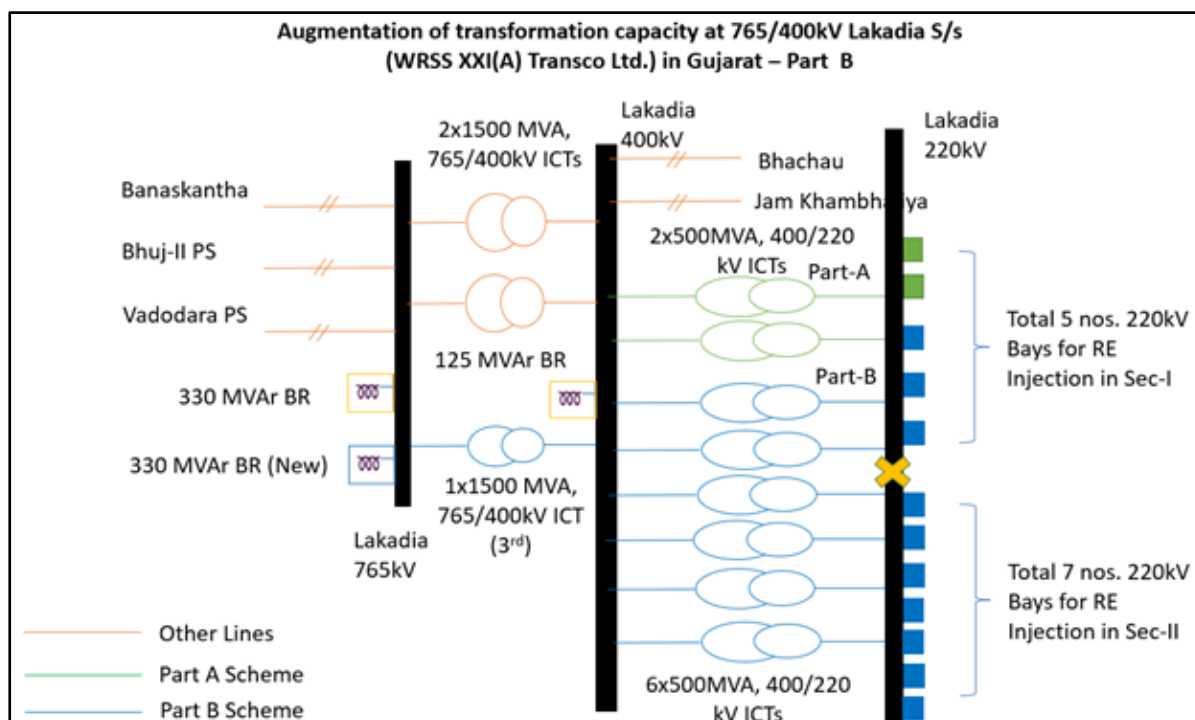

Figure 5-2: Schematic of Lakadia S/s representing augmentation of transformation capacity.

(d) Augmentation of Transformation Capacity at 765/400/220kV Vadodara (GIS) S/s in Gujarat by 400/220kV, 1x500MVA ICT (3rd)

3x1500MVA 765/400kV & 2x500MVA 400/220kV Vadodara (GIS) S/s is an existing substation implemented by POWERGRID through RTM Route.

However, during the joint study meeting held amongst CEA, CTU, GRID-INDIA & GETCO on 23.02.2024, the instant augmentation scheme was proposed to maintain redundancy and reliability during drawal of power at Vadodara S/s. This scheme also enables to maintain N-1 criterion compliance requirement. The scheme was discussed and approved in the 27th CMETS-WR meeting held on 01.04.2024. Further, the scheme was awarded to POWERGRID under RTM for implementation vide CTU OM dated 14.06.2024. The detailed scope of work of this scheme is given below.

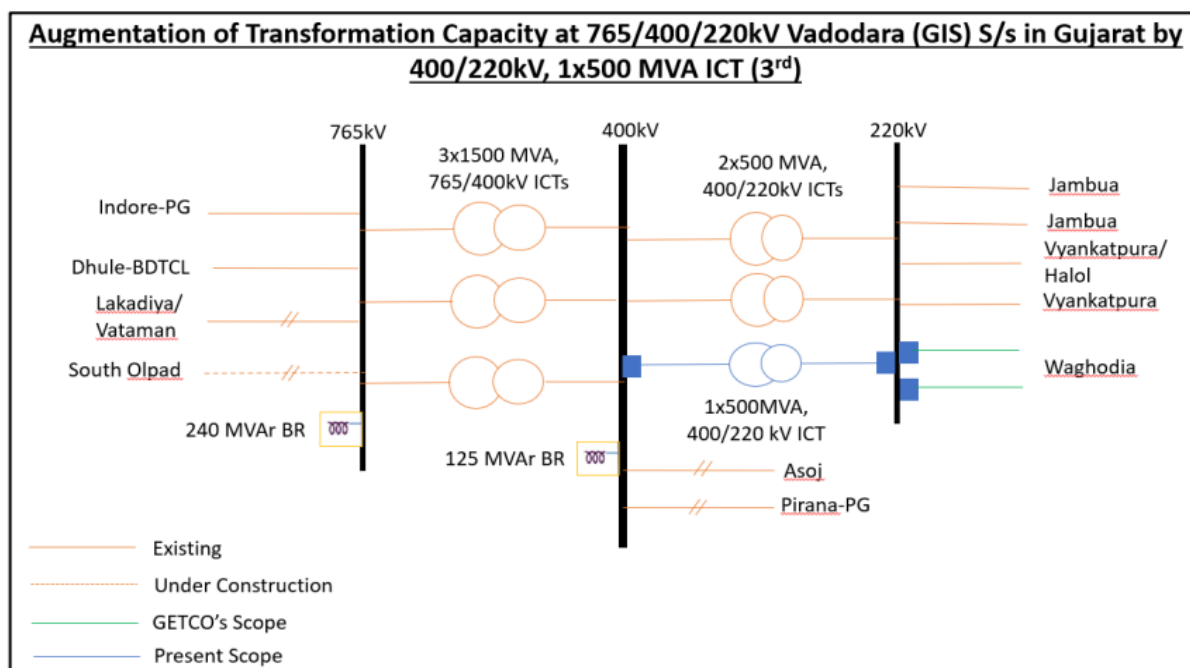

Figure 5-3: Schematic of Vadodara S/s representing augmentation of transformation capacity.

Detailed scope of work:

Sl. No.	Scope of the Transmission Scheme	Item Description
1.	Augmentation of Transformation Capacity at 765/400/220kV Vadodara (GIS) S/s in Gujarat by 400/220kV, 1x500MVA ICT (3 rd)	<ul style="list-style-type: none"> • 400/220kV, 1x500MVA ICT – 1 No. • 400kV ICT bay (GIS) – 1 no. • 220kV ICT bay GIS) – 1 No. • 400kV GIS Bus duct (m) – 250m. approx. • 220 kV GIS Bus duct (m) – 450m. approx.
2.	2 nos. 220kV bays at Vadodara S/s (for Vadodara (PG) – Waghodia D/c line)	<ul style="list-style-type: none"> • 220kV line bays (GIS): 2 Nos. • 220kV GIS Bus duct (m) – 300m. approx.

Note:

- Implementation timeframe has been aligned with the time-frame for implementation of Vadodara (PG) – Waghodia 220kV D/c line as confirmed by GETCO.

Implementation timeframe: Mar-26 (with minimum implementation schedule of 21 months from SPV transfer).

Estimated Cost: Rs. 85.79 Crs.

(e) Augmentation of transformation capacity at Banaskantha (Raghanesda) PS (GIS)

400/220kV Banaskantha PS is an existing S/s with transformation capacity of 2x500MVA, 400/220kV ICTs, planned to enable injection of RE power from the 700MW GPCL’s

Radhanesda Solar Power Park. M/s Sprng Power Earth Pvt. Ltd. was granted Connectivity for injection of 250MW RE power.

Subsequently, applications were received for additional 300MW Connectivity at Banaskantha PS. To enable the injection of additional 300MW RE power maintaining N-1 criterion compliance, the subject scheme was proposed. The scheme was deliberated and approved under TBCB in the 21st NCT meeting held on 06.08.2024 with implementation time frame of 24 months from the date of SPV transfer.

Detailed scope of work:

Sl. No.	Scope of the Transmission Scheme	Capacity /km
1.	Augmentation of transformation capacity at Banaskantha (Raghanesda) PS (GIS) by 2x500 MVA 400/220 kV ICTs (3 rd & 4 th)	<ul style="list-style-type: none"> 500 MVA, 400/220 kV ICTs: 2 Nos. 400 kV ICT bays: 2 Nos. (+ 2 Nos. for dia completion with provision of Switchable LR) 220 kV ICT bays: 2 Nos.

Implementation timeframe: 24 months from the date of SPV transfer.

Estimated Cost: Rs. 172 Crs.

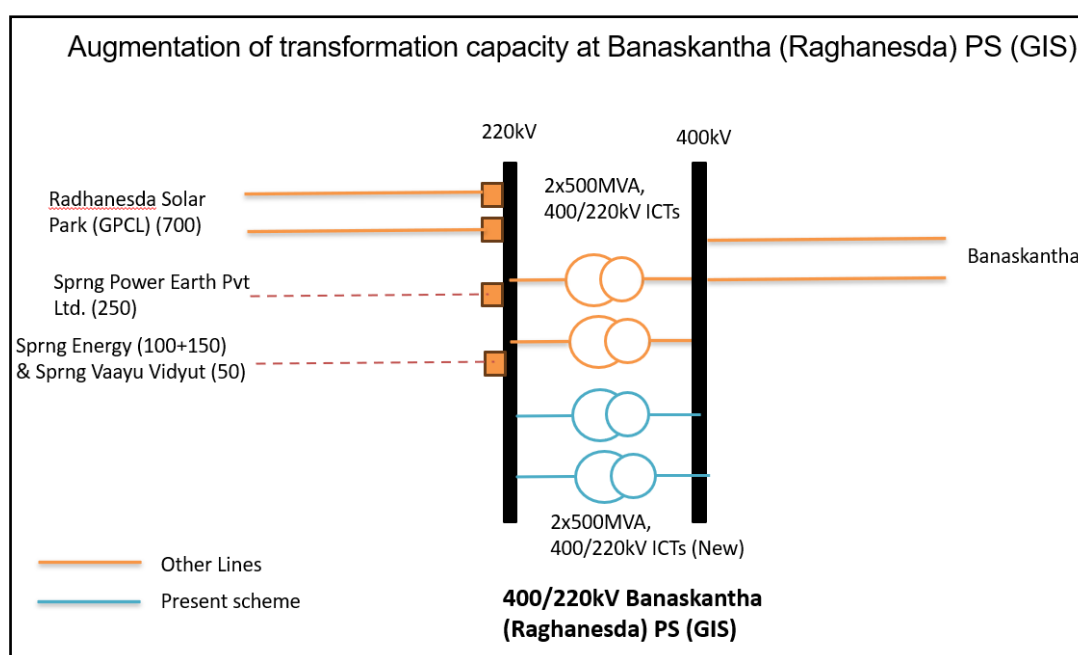

Figure 5-4: Schematic of Banaskantha PS representing augmentation of transformation capacity.

(f) Transmission system to provide redundant power supply to Dholera area

In order to provide power supply to the semiconductor manufacturing industries in Dholera SIR area of Gujarat, GETCO has already established 220/33kV Dholera S/s along with Panchham – Dholera 400kV D/c line which is presently charged at 220kV level. However, in view of a redundant 2nd source of power, GETCO vide letter dated 22.07.2024, has proposed

ISTS connectivity from Vataman substation, for drawal of 150-200MW at new proposed Dholera-2 S/s of GETCO in Jan-26 time-frame.

765kV Vataman Switching Substation is under implementation with SCOD of Dec'25. Subsequently, implementation of 2x1500MVA 765/400kV ICTs at Vataman S/s was approved in the 20th NCT meeting to enable evacuation of power from offshore wind projects in Gujarat in matching timeframe with offshore wind (Mar'29).

The interconnection of Vataman S/s (ISTS) with 220kV Dholera-2 S/s proposed by GETCO would require preponement of 2x1500MVA 765/400kV ICTs (agreed for offshore wind projects), from Mar-29 to an earlier time-frame as well as Installation of 2x500MVA 400/220kV ICTs and 2 nos. 220kV line bays at Vataman S/s. In this regard, the subject scheme was agreed for with the following scope of work in the 31st CMETS-WR held on 02.08.2024. The scheme was deliberated and approved under RTM mode in the 22nd NCT meeting held on 23.08.2024 with implementation time frame as mentioned below:

Detailed scope of work:

Sl. No.	Scope of the Transmission Scheme	Capacity /km
A. Transmission System for Offshore Wind (required to be preponed)		
1.	Creation of 400kV switchyard along with Installation of 2x1500 MVA, 765/400 kV ICTs at Vataman (AIS) with 2x125 MVar (420 kV) Bus Reactors	<ul style="list-style-type: none"> • 765/400kV, 1500 MVA, ICTs – 2 nos. (7x500MVA incl. spare unit) • 765kV ICT bays – 2 nos. • 400kV ICT bays – 2 nos. • 2x125 MVAR, 420kV Bus Reactor – 1 no. • 400kV Bus Reactor Bay – 2 no.
B. Additional Transmission System Proposed for redundant power supply to Dholera area		
2.	Creation of 220kV switchyard along with Installation of 2x500 MVA, 400/220 kV ICTs at Vataman (AIS)	<ul style="list-style-type: none"> • 400/220kV, 500 MVA, ICTs – 2 nos. • 400kV ICT bays – 2 nos. • 220kV ICT bays – 2 nos.
3.	2 Nos. 220kV line bays for Vataman – Dholera-2(GETCO) 220kV D/c line	<ul style="list-style-type: none"> • 220kV line bays – 2 nos.

Note:

- GETCO shall implement Vataman – Dholera-2(GETCO) 220kV D/c line in matching time-frame

Implementation time-frame: 18 months from award to implementing agency

Estimated cost: Rs. 110 Crs.

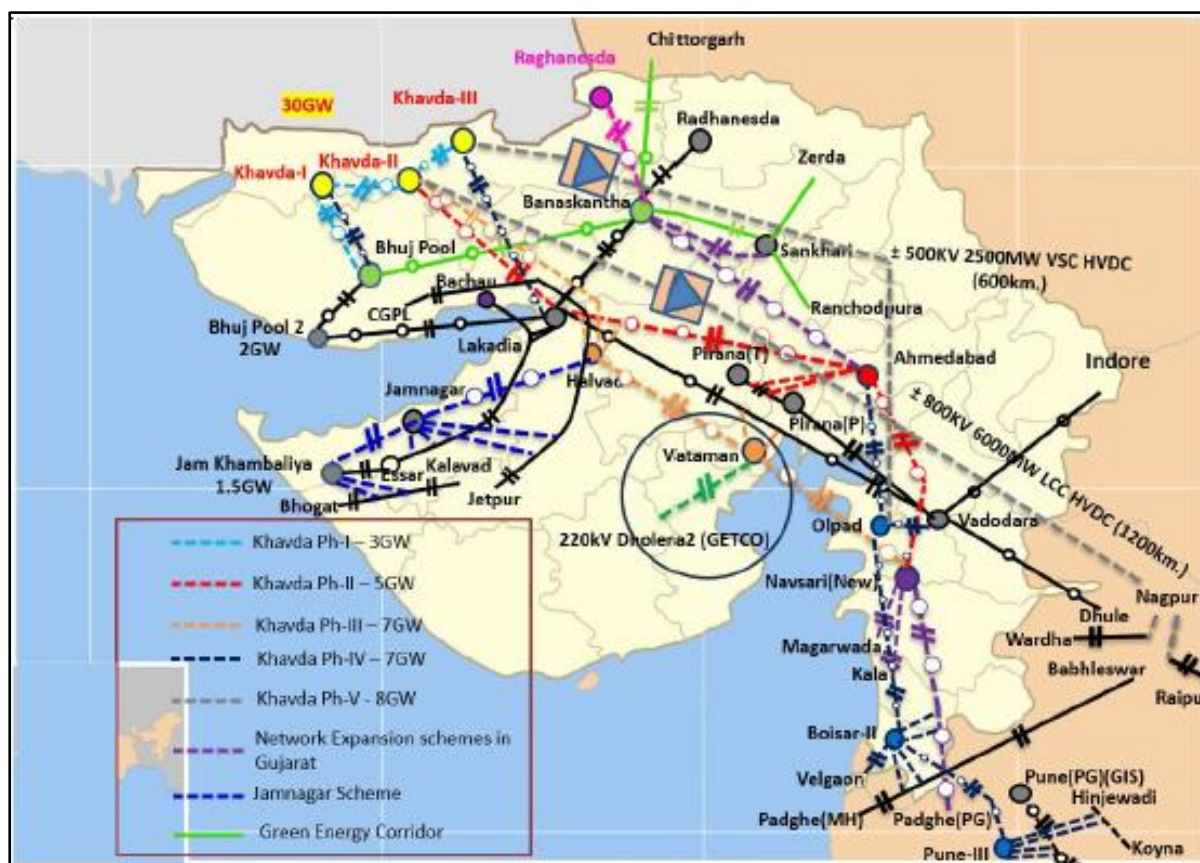

Figure 5-5: Representation of Tr. system to provide redundant power supply to Dholera area of Gujarat

(g) Bays at Vataman S/s for Vataman – Saurashtra 765kV D/c line

Establishment of 2x1500MVA, 765/400kV Saurashtra S/s (near Rajkot), 765 kV D/C Vataman (ISTS) – Saurashtra line (with bays at both ends) (along with other transmission elements) is being taken up by GETCO for implementation. In this regard, GETCO vide letter dated 30.05.2024, has requested for implementation of 2 nos. 765kV bays at Vataman (ISTS) S/s for Saurashtra – Vataman 765kV D/c line (expected by Mar’27) under ISTS to ensure smooth execution of work. The request from GETCO was agreed for in the 30th CMETS-WR meeting held on 02.07.2024.

Detailed scope of work:

Sl. No.	Scope of the Transmission Scheme	Capacity /km
1.	2 No. 765kV bays at Vataman S/s (of Vataman Tr. Limited) for Vataman – Saurashtra 765kV D/c line of GETCO	765kV line bay – 2 No.

Implementation time-frame: 31.03.2027

(h) 220kV line bays at Vapi-II S/s for LILO of 220 KV Chikhli – Vapi 220kV S/c line at Vapi-II

Establishment of Vapi-II with 2x500MVA, 400/220kV ICTs & 4 nos. 220kV bays (for GETCO) is already being implemented under ISTS by Sterlite Grid 4 Ltd. Subsequently, Transmission scheme for implementation of LILO of Kakrapar-Vapi 220kV D/c (ISTS) line & LILO of 220 KV Chikhli – Vapi 220kV S/c line at Vapi-II S/s was taken up by GETCO requiring 2 additional bays at Vapi-II S/s.

In this regard, GETCO, vide letter dated 30.05.2024, has requested for implementing the above two bays (in addition to the 4 bays granted earlier) under ISTS.

Subsequent to the deliberations regarding the implementation timeframe, the subject scheme was agreed for implementation under ISTS in the 31st CMETS-WR held on 02.08.2024 and is currently under approval.

Detailed scope of work:

Sl. No.	Scope of the Transmission Scheme	Capacity /km
1.	2 nos. 220kV line bays at Vapi-II S/s for LILO of 220 KV Chikhli – Vapi 220kV S/c line at Vapi-II	220kV line bays – 2 Nos. (GIS)

Note:

- GETCO shall match LILO of 220 KV Chikhli – Vapi 220kV S/c line at Vapi-II with the time-frame of commissioning of 220kV bays under ISTS.

Implementation time-frame: 21 months from award to implementing agency.

(i) Implementation of 220kV line bays at Bhuj PS for RE Interconnection

765/400/220kV Bhuj PS is an existing substation of POWERGRID with 4x1500MVA, 765/400kV ICTs & 8x500MVA 400/220kV ICTs. 9th 400/220kV ICT is being implemented by POWERGRID with schedule of 01.07.2025. M/s Indianoil NTPC Green Energy Private Limited (INGEPL) has applied for Connectivity vide application no. 2200000634 for 600MW RE power injection from 30.06.2026. The subject scheme is planned to enable the Connectivity of M/s INGEPL.

Detailed scope of work:

Sl. No.	Scope of the Transmission Scheme	Capacity /km
1.	Implementation of 2 nos. 220kV line bays at Bhuj PS for Interconnection of Solar Project of Indianoil NTPC Green Energy Private Limited (INGEPL) (Appl. No. 2200000634)	2 Nos. Hybrid/MTS Bays

Implementation time-frame: 30.06.2026

Estimated cost: Rs. 12.7 Crs.

(j) Transmission System for evacuation of RE power from Raghnesda area of Gujarat – 3 GW under Phase-I

Raghanesda region in Banaskantha District of Gujarat has been declared a potential Renewable Energy (RE) zone with potential of 5 GW in the initial phase (i.e. related to 1 GW RE park of GPCL and 4 GW RE park of M/s Torrent for which land allocation by Government of Gujarat is under process). 2.5GW out of 4GW Solar Capacity of Torrent and 0.5GW out of 1GW RE park of GPCL is being considered under ISTS under Phase-I planning. Presently, connectivity under GNA has been received for 0.6GW (3x200 MW from M/s Sprng) at Raghanesda PS.

The scheme was discussed and agreed upon in the WRPC meeting held on 27.03.2024. Subsequently, the scheme was also deliberated and approved in the 20th NCT meeting held on 25.06.2024 for implementation under TBCB route with implementation timeframe of 30 months.

Detailed scope of work:

Sl. No.	Scope of the Transmission Scheme	Capacity/ kM
1.	<p>Establishment 3x1500 MVA, 765/400 kV Substation near Raghanesda (GIS) with 2x330 MVAR, 765 kV bus reactor and 2x125 MVAR, 420 kV bus reactor</p> <p>Future provision (space for):</p> <ul style="list-style-type: none"> • 765/400 kV ICT along with bays- 5 Nos. (1 No. in Sec-I & 4 Nos. on Sec-II) • 765 kV line bays along with switchable line reactors – 10 Nos. (4 Nos. on Sec-I & 6 Nos. on Sec-II) • 765 kV Bus Reactor along with bay: 2 Nos. (on Sec-II) • 765 kV Sectionalizer: 1 -set • 400 kV line bays along with switchable line reactors– 12 Nos. (4 Nos. on Sec-I & 8 Nos. on Sec-II) • 400/220 kV ICT along with bays - 8 Nos. (4 Nos. on each 400 kV Section) • 400 kV Bus Reactor along with bays: 2 Nos. (Sec-II) • 400 kV Sectionalization bay: 1- set • 220 kV line bays: 12 Nos. (6 Nos. on each 220 kV Section) • 220 kV Sectionalization bay: 1 set • 220 kV BC: 1 No. • Establishment of 6000 MW, ± 800 kV Raghanesda (HVDC) [LCC] terminal station (4x1500 MW) along with associated interconnections with 400 kV HVAC Switchyard & all associated equipment (incl. filters)/bus extension, etc. 	<ul style="list-style-type: none"> • 765/400 kV, 1500 MVA ICT – 3 Nos. (10x500 MVA single phase units including one spare ICT Unit) • 765 kV ICT bays – 3 Nos. • 400 kV ICT bays – 3 Nos. • 765 kV Line bays – 2 Nos. • 1x330 MVar, 765 kV bus reactor- 2 Nos. (7x110 MVAR single phase Reactors including one spare Unit for bus /line reactor) • 765 kV Bus reactor bay – 2 Nos. • 125 MVar, 420 kV reactor- 2 Nos. • 400 kV Reactor bay- 2 Nos. • 400 kV line bays - 4 Nos. (for interconnection of RE Projects)

2.	Raghanesda (GIS) – Banaskantha (PG) 765 kV D/c line	95 km
3.	2 Nos. 765 kV line bays at Banaskantha (PG) S/s	765 kV line bays – 2 Nos.

Note:

- TSP of Banaskantha S/s (POWERGRID) shall provide space for scope at Sl. 3 above.

Implementation timeframe: 30 months from the date of SPV transfer.

Estimated Cost: Rs. 1855 Crs.

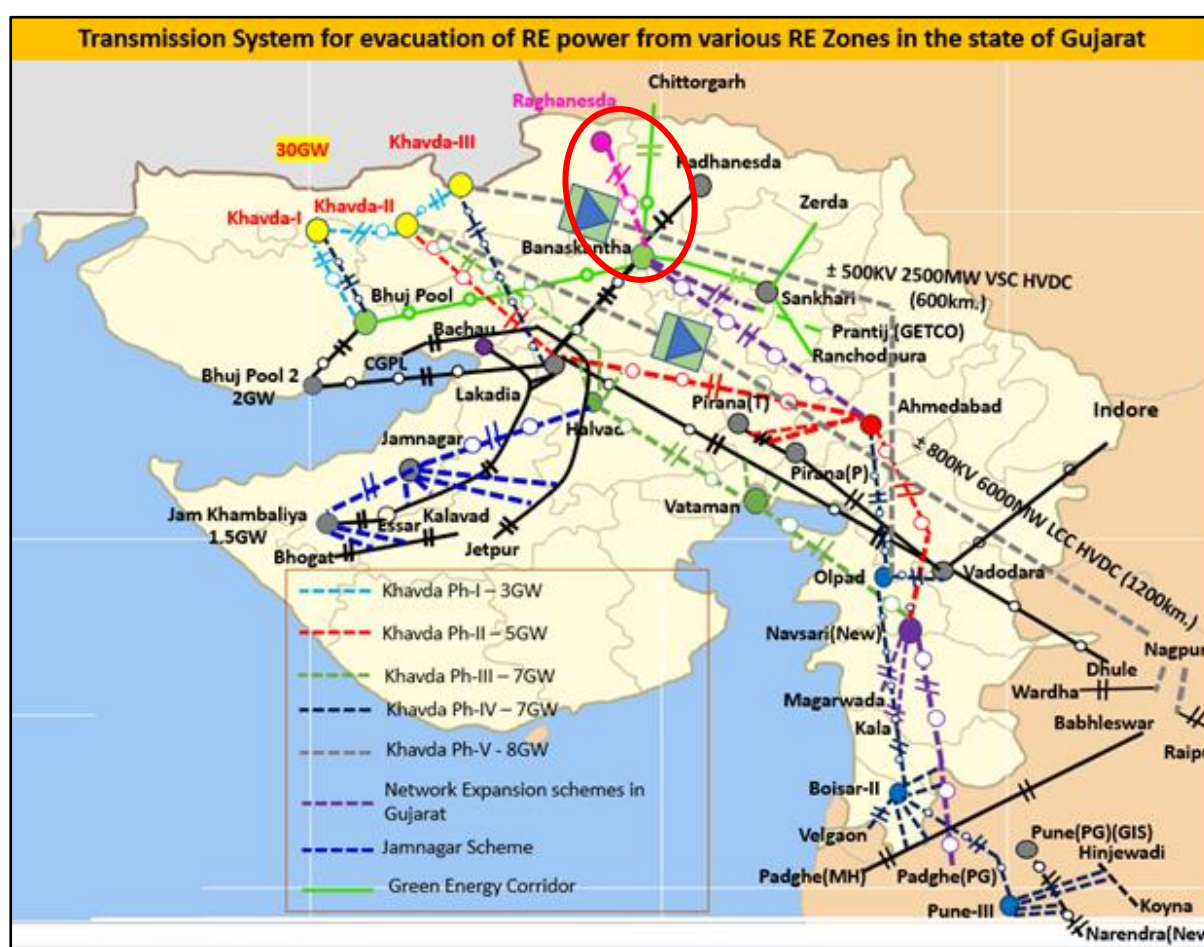

Figure 5-6: Schematic representation of Tr. system for evacuation of RE power from Raghanesda area of Gujarat – 3 GW under Phase-I.

(k) Transmission System for evacuation of Green Hydrogen/Ammonia potential in Kandla area of Gujarat (Phase-I: 3 GW)

Hon'ble Prime Minister of India has announced Hydrogen Mission on 15th August, 2021 which is a major step towards decarbonizing the energy system and thereby complementing other decarbonization technologies like renewable power and biofuels. Ministry of Power has issued Hydrogen Policy vide letter dated 17th February 2022 with a motive to facilitate the transition from fossil fuel/ fossil fuel-based feedstock to Green Hydrogen/ Green Ammonia both as energy carriers and chemical feedstock for different sectors.

During the further round of discussions in the meetings held by Hon'ble MNRE & CEA, regarding the capacity, different locations, tentative timelines and power demand etc., it was concluded that, there is a power drawal requirement of 2.2GW by 2027-28 progressively increasing up to 6GW by 2030 in the Kandla area of Gujarat.

In view of the envisaged network requirements by the year 2027-28, the subject scheme is proposed to cater to the power drawal requirement of up to 3GW under Phase-I with implementation timeframe of 24 months (by the year 2027-28).

The scheme was discussed in 49th WRPC meeting held on 03.05.2024 and in the 21st NCT meeting held on 06.08.2024 wherein it was recommended for implementation under TBCB route with the following scope of work.

Detailed scope of work:

Sl. No.	Scope of the Transmission Scheme	Capacity/line length km
1.	<p>Establishment of 3X1500 MVA 765/400 kV Kandla (GIS) with 2X330 MVAR 765 kV bus reactor and 2X125 MVAR 420 kV bus reactor.</p> <p>Future Scope (Space for):</p> <ul style="list-style-type: none"> • 765/400 kV ICT along with bays-3 Nos. (on Sec-II) • 765 kV line bays along with switchable line reactors – 2 Nos. (on Sec-I) & 6 Nos. (on Sec-II) • 765 kV Bus Reactor along with bay: 2 Nos. (on Sec-II) • 765 kV Sectionalizer: 1 -set • 400 kV line bays along with switchable line reactors– 14 Nos. (6 on Sec-I & 8 on Sec-II) • 400/220 kV ICT along with bays-6 Nos. (3 Nos. each on Sec-I & Sec-II) • 400 kV Bus Reactor along with bays: 2 Nos. (Sec-II) • 400 kV Sectionalization bay: 1-set • 220 kV line bays: 12 Nos. (6 nos. each on Sec-I & Sec-II) • 220 kV Sectionalization bay: 1set • 220 kV BC: 2 Nos. • STATCOM (\pm400 MVAR) along with 2x125 MVA MSC & 1x125 MVA MSR and associated bays-2Nos. (1 on 400kV Sec-I and 1 on 400 kV Sec-II) 	<ul style="list-style-type: none"> • 765/400 kV, 1500 MVA ICT-3 • 765 kV ICT bays- 3 • 400 kV ICT bays- 3 • 330 MVAR 765 kV bus reactor- 2 • 125 MVAR 420 kV bus reactor- 2 • 765 kV reactor bay- 2 • 765 kV line bay- 2 • 400 kV reactor bay- 2 • 500 MVA, 765/400 kV 1-Ph Spare ICT-1 • 110 MVAR, 765 kV, 1-ph reactor (spare unit for line/bus reactor)-1
2.	Halvad – Kandla(GIS) 765kV D/c line	140 km
3.	2 Nos. of 765kV line bays at Halvad for termination of Halvad – Kandla 765kV D/c line	<ul style="list-style-type: none"> • 765 kV line bays– 2 Nos. (for Halvad end)

Sl. No.	Scope of the Transmission Scheme	Capacity/line length km
4.	240 MVAR switchable line reactors on each ckt at Kandla (GIS) end of Halvad – Kandla 765kV D/c line (with NGR bypass arrangement)	<ul style="list-style-type: none"> • 240 MVAR, 765 kV switchable line reactor- 2 Nos. • Switching equipment for 765 kV line reactor- 2 Nos. • 80 MVAR, 765 kV, 1-ph reactor (spare unit for line/bus reactor)-1 Nos.
5.	±400 MVAR STATCOM along with 2x125 MVAR MSC & 1x125 MVAR MSR at Kandla(GIS) 400 kV Bus section-I	<ul style="list-style-type: none"> • ±400 MVAR STATCOM along with 2x125 MVAR MSC & 1x125 MVAR MSR • 400 kV bay – 1 Nos.

Note:

- As per initial discussions with Deen Dayal Port Authority w.r.t. land allocation done to various Green Hydrogen/Ammonia developers in Kandla area, Kandla S/s is proposed to be located near Bhimasar area and line length of Kandla-Halvad line has been considered accordingly. However, exact location of the substation is to be finalized by the surveying agency in consultation with Deen Dayal Port Authority and other stakeholders.
- TSP of Halvad S/s shall provide space for scope at Sl. 3 above.

Implementation timeframe: 24 months from the date of SPV transfer.

Estimated Cost: Rs. 2775 Crs.

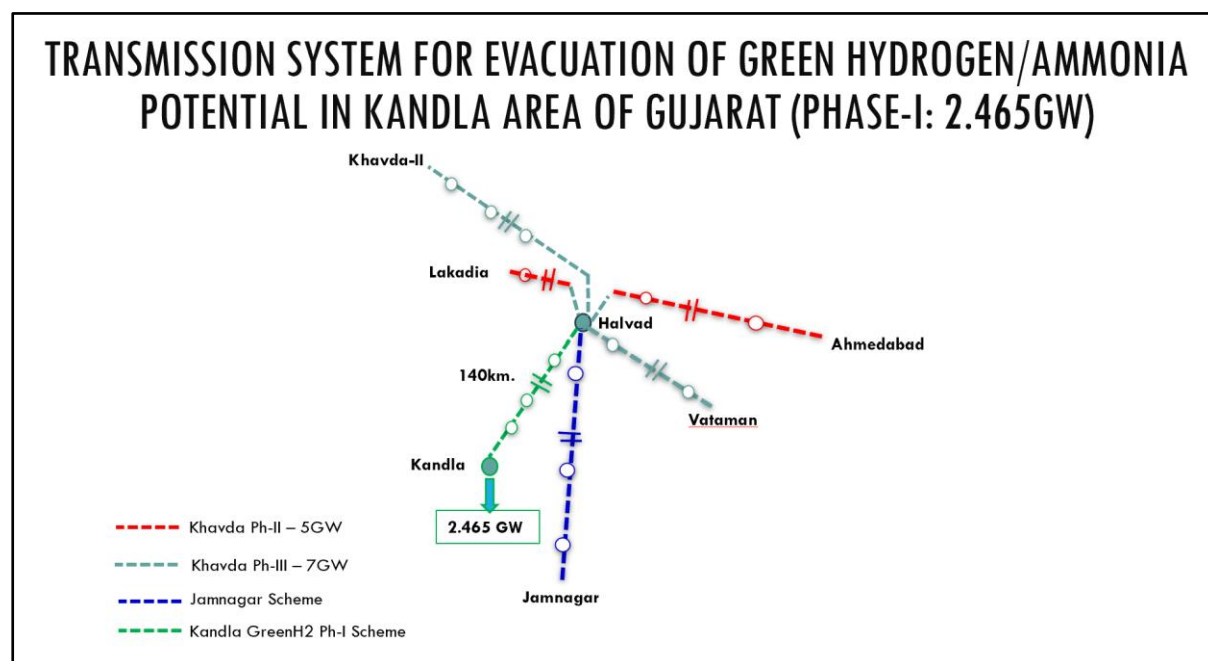

Figure 5-7: Schematic representation of Ts. system for evacuation of Green Hydrogen/Ammonia potential in Kandla area of Gujarat (Phase-I: 3 GW)

(I) Transmission System for supply of power to Green Hydrogen/Green Ammonia manufacturing potential in Mundra area of Gujarat under Phase-I

During the meetings held by Hon'ble MNRE & CEA, it was concluded that, there is a power drawal requirement of 6GW by 2027-28 progressively increasing up to 22GW by 2030 in the Mundra area of Gujarat.

765/400kV Navinal (Mundra) (GIS) was planned with 4x1500MVA, 765/400kV ICTs through LILO of Bhuj-II – Lakadia 765 kV D/c line at Navinal (Mundra) (GIS) S/s for meeting the demand of bulk consumers (3000MW) and for meeting the demand of Green Hydrogen/Ammonia manufacturers (1500MW) under Phase-I Part-A. This scheme is currently under bidding.

Further, in view of the envisaged network requirement by the year 2027-28, the subject scheme is proposed in two parts to cater to the power drawal requirement of up to 10.5GW under Phase-I with scope of work as follows.

Transmission System for evacuation of Green Hydrogen/Ammonia potential in Mundra area of Gujarat under Phase-I: Part B1 scheme (6GW at Navinal S/s):

- Augmentation of Transformation capacity at 765/400 kV Navinal (Mundra) S/s (GIS) by 2x1500 MVA ICTs (New Bus Section-II)
- Navinal(Mundra) (GIS) – Bhuj 765kV D/c line (70km.)
- ± 400 MVAr STATCOM at Navinal(Mundra) (GIS) 400kV Bus section-I
- ± 400 MVAr STATCOM at Navinal(Mundra) (GIS) 400kV Bus section-II

Transmission System for evacuation of Green Hydrogen/Ammonia potential in Mundra area of Gujarat under Phase-I: Part B2 scheme (3.5GW at Navinal-II S/s):

- Establishment of 6x1500 MVA, 765/400 kV Navinal-II (Mundra) S/s (GIS) with 2x330 MVAR, 765 kV & 2x125MVAr, 420 kV bus reactors (In 2 bus sections)
- LILO of KPS3 (GIS) – Lakadia 765kV D/c line at Navinal-II (Mundra) (GIS) S/s
- Navinal-II (Mundra) (GIS) – Bhuj-II (GIS) 765kV D/c line
- ± 400 MVAr STATCOM at Navinal-II (Mundra) (GIS) 400kV Bus section-I
- ± 400 MVAr STATCOM at Navinal-II (Mundra) (GIS) 400kV Bus section-II

The scheme was discussed in 49th WRPC meeting held on 03.05.2024 and in the 21st NCT meeting held on 06.08.2024 wherein it was decided that the scheme may again be examined jointly by CEA, CTUIL and Grid India.

Accordingly, considering the space availability for adequate reactive power compensation & drawal of huge load (more than 10GW) from a single substation (Navinal) from resiliency point of view, the scope of work was modified in a subsequent meeting held on 14.08.2024. Subsequently, in 22nd NCT meeting held on 23.08.2024, NCT recommended Transmission system for supply of power to Green Hydrogen/Ammonia manufacturing potential in Mundra area of Gujarat under Phase-I: Part B1 scheme (3 GW at Navinal S/s)” as mentioned below:

Detailed scope of work:

Transmission System for evacuation of Green Hydrogen/Ammonia potential in Mundra area of Gujarat under Phase-I: Part B1 scheme (3GW at Navinal S/s)

- Augmentation of Transformation capacity at 765/400 kV Navinal(Mundra) S/s (GIS) by 2x1500 MVA ICTs (New Bus Section-II)
- Navinal(Mundra) (GIS) – Bhuj 765kV D/c line (70km.)
- ± 300 MVAr STATCOM along with MSC (2x125 MVAr) & MSR (1x125 MVAr) at Navinal (Mundra) (GIS) 400kV Bus section-I
- ± 300 MVAr STATCOM along with MSC (2x125 MVAr) & MSR (1x125 MVAr) at Navinal (Mundra) (GIS) 400kV Bus section-II

Estimated cost: Rs. 2817 Crs.

Implementation timeframe: 36 Months from date of allocation to implementing agency

In 22nd NCT meeting, it was decided that initial applications for drawal of power at Navinal from Green Hydrogen/Ammonia manufacturers would be accommodated at Navinal-I S/s (cumulative upto 4.5 GW). Therefore, Part B2 scheme (details given below) may be deferred at present and would be taken up for deliberation subsequently based on receipt of applications from Green Hydrogen/Ammonia manufacturers at Navinal-I S/s.

Transmission System for evacuation of Green Hydrogen/Ammonia potential in Mundra area of Gujarat under Phase-I: Part B2 scheme (7.5GW at Navinal-II S/s)

- Establishment of 6x1500 MVA, 765/400 kV Navinal-II (Mundra) S/s (GIS) with 2x330 MVAr, 765 kV & 2x125MVAr, 420 kV bus reactors (In 2 bus sections)
- LILO of KPS3 (GIS) – Lakadia 765kV D/c line at Navinal-II (Mundra) (GIS) S/s
- Navinal-II (Mundra) (GIS) – Bhuj-II (GIS) 765kV D/c line
- ± 2 x300MVAr STATCOMs at Navinal-II (Mundra) (GIS) 400kV Bus section-I
- ± 2 x300MVAr STATCOMs at Navinal-II (Mundra) (GIS) 400kV Bus section-II

Estimated cost: Rs. 6405 Crs.

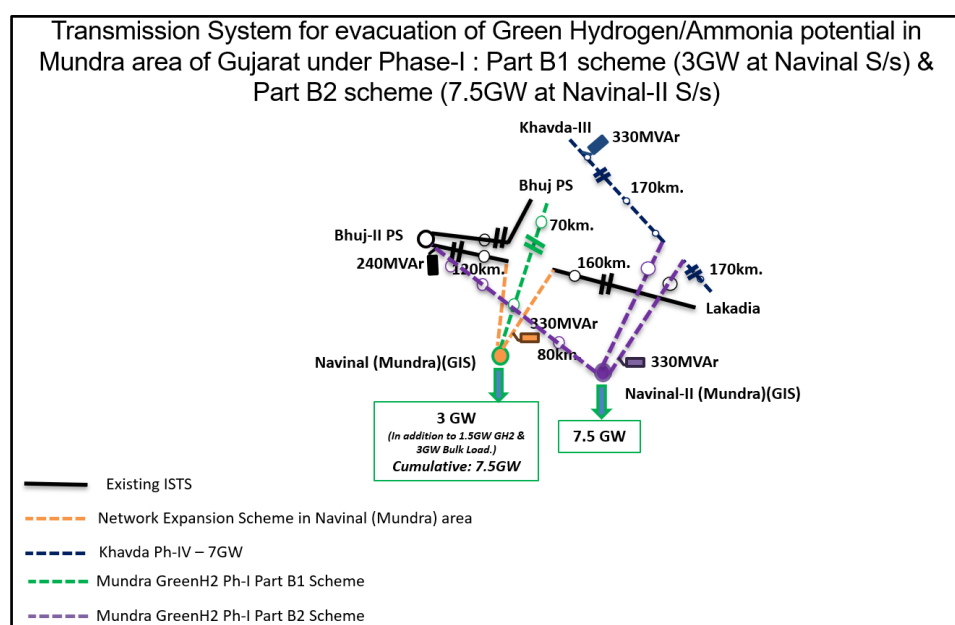

Figure 5-8: Schematic representation of Tr. system for supply of power to Green Hydrogen/Green Ammonia manufacturing potential in Mundra area of Gujarat under Phase-I

(m) Transmission System for Offshore Wind Zone Phase-1 (500 MW VGF off the coast of Gujarat for Subzone B3)

MNRE has identified about 30 GW Offshore wind potential each off the coast of Gujarat and Tamil Nadu. Initially 5 GW Offshore wind potential each at Gujarat (CUF – 38%) and Tamil Nadu (CUF – 48%) has been prioritized for implementation wherein 2 GW transmission capacity (1 GW each off the coast of Gujarat and Tamil Nadu) will be developed in Phase-I and further 4 GW each off the coast of Gujarat and Tamil Nadu shall be developed subsequently.

In this regard, following broad decisions were taken in the meeting held on 22.12.2023, regarding tentative timelines for the offshore wind energy projects:

- 500 MW VGF project off-Gujarat coast to be commissioned by March 2028. Tender for the project to be published by March 2024.
- 500 MW VGF project off-Tamil Nadu coast to be commissioned by March 2029. Tender for the project to be published by March 2025.
- 4 GW non-VGF project off-Tamil Nadu coast to be commissioned in FY 2029- 30. Tender for the projects to be published on 01.02.2024.
- Non-VGF project off-Gujarat coast will be tendered based on the response for the Tamil Nadu non-VGF project

The scheme was discussed and agreed upon in the WRPC meeting held on 27.03.2024. Further, in a meeting held on 14.06.2024 under the chairmanship of Hon'ble MoP & MNRE, it was decided that the subject project may be awarded to POWERGRID for implementation under RTM.

As per the press release dated 19.06.2024 from PIB, the Union Cabinet have approved the Viability Gap Funding (VGF) scheme for offshore wind energy projects for installation and commissioning of 1 GW of offshore wind energy projects. The scheme was deliberated and approved in the 20th NCT meeting held on 25.06.2024 for implementation by POWERGRID under RTM mode. The subject scheme was awarded to POWERGRID vide CTU letter dated 20.08.2024. The detailed scope of work is given below.

Detailed scope of work:

Sl. No.	Scope of the Transmission Scheme	Capacity /km
A. Transmission System onwards Onshore Pooling Station		
1.	Establishment of 2x500 MVA, 400/220 kV Mahuva Onshore Pooling Station (GIS) (Mahuva PS) alongwith 1x125 MVAR, 420 kV bus reactor (with space provision for upgradation to 765 kV level to cater to future Offshore Wind Projects adjacent to B3, B4, B5 pockets in future)	<ul style="list-style-type: none"> • 400/220kV, 500 MVA, ICTs – 2 nos. • 400kV ICT bays – 2 nos. • 220kV ICT bays – 2 nos. • 1x125 MVAR, 420kV Bus Reactor – 1 no. • 400kV Bus Reactor bay – 1 no.

Sl. No.	Scope of the Transmission Scheme	Capacity /km
A. Transmission System onwards Onshore Pooling Station		
	<p>Future Space Provisions:</p> <ol style="list-style-type: none"> i. 765/400 kV ICT along with bays- 6 Nos. ii. 765 kV line bays along with switchable line reactors – 8 Nos. iii. 765 kV Bus Reactor along with bay: 2 Nos. iv. 765 kV Sectionalizer: 1 -set v. 400 kV line bays along with switchable line reactors– 8 Nos. vi. 400/220 kV ICT along with bays -8 Nos. vii. 400 kV Bus Reactor along with bays: 3 Nos. viii. 400 kV Sectionalization bay: 1- set ix. 220 kV line bays: 16 Nos. x. 220 kV Sectionalization bay: 1 set xi. 220 kV BC and TBC: 1 No. xii. STATCOM (± 300 MVAR) alongwith associated bay at 220 kV - 3 Nos. xiii. 220kV Bus Reactor along with bays: 7 Nos. xiv. VSR (420kV, 1x125 MVAR Variable Bus Shunt Reactor with OLTC with control range between 50 – 125 MVAr for each VSR) alongwith associated bay at 400 kV – 3 Nos. 	<ul style="list-style-type: none"> • 400kV line bays – 2 nos. (for termination of Mahuva Onshore PS (GIS) – Vataman 400 kV D/c line) • 220kV line bays – 2 nos. (for termination of B3-OSS-1 – Mahuva Onshore PS 220 kV 2xS/c (3 core) cables) • 220 kV Bus Coupler (BC) Bay – 1 no.
2.	Creation of 400kV switchyard along with Installation of 2x1500 MVA, 765/400 kV ICTs at Vataman (AIS) with 2x125 MVAr (420 kV) Bus Reactors	<ul style="list-style-type: none"> • 765/400kV, 1500 MVA, ICTs – 2 nos. (7x500MVA incl. spare unit) • 765kV ICT bays – 2 nos. • 400kV ICT bays – 2 nos. • 2x125 MVAR, 420kV Bus Reactor – 1 no. • 400kV Bus Reactor bay – 2 no.
3.	2 nos. 400kV bays at Vataman for termination of Mahuva Onshore PS (GIS) – Vataman 400 kV D/c line	<ul style="list-style-type: none"> • 400kV line bays – 2 nos.
4.	Mahuva Onshore PS (GIS) – Vataman 400 kV D/c line (Quad ACSR/AAAC/AL59 moose equivalent) with 63MVAr & 50 MVAr, 420 kV switchable line reactors on each ckt at Mahuva & Vataman ends respectively.	<p>Line length: 190 km</p> <p>420 kV, 63 MVAr switchable line reactors at Mahuva S/s end– 2 Nos.</p> <p>Switching equipment for 420 kV, 63 MVAr switchable line reactors at Mahuva S/s end – 2 no</p> <p>420 kV, 50 MVAr switchable line reactors at Vataman S/s end– 2 Nos.</p>

Sl. No.	Scope of the Transmission Scheme	Capacity /km
A. Transmission System onwards Onshore Pooling Station		
		Switching equipment for 420 kV, 50 MVAR switchable line reactors at Vataman S/s end – 2 no
5.	± 300 MVAR STATCOM at 220 kV level of Mahuva PS (GIS) with 1 No. of 220 kV bay	<ul style="list-style-type: none"> • ± 300 MVAR STATCOM – 1 No. • 220 kV bay – 1 no.
6.	420 kV, 1x125 MVAR Variable Bus Shunt Reactor with OLTC (control range between 50 – 125 MVAR for VSR) with 1 No. of 400 kV bay	<ul style="list-style-type: none"> • 1x125 MVAR, 420kV Variable Bus Shunt Reactor with OLTC – 1 no. • 400kV Bus Reactor bay – 1 no.
7.	245 kV, 3x50 MVAR Bus Reactors at 220 kV level of Mahuva PS (GIS)	<ul style="list-style-type: none"> • 50 MVAR, 245kV Bus Reactor– 3 no. • 220kV Bus Reactor bay – 3 no.
B. Transmission System for integration of Offshore Wind Farms with Onshore PS		
Offshore Substation-1 {500 MW VGF}		
1.	Establishment of 2x315 MVA, 220/66 kV Gujarat Offshore B3 Sub-Station Station-1 (B3-OSS-1) with 66 kV line bays – 10 Nos. for RE Interconnection	<ul style="list-style-type: none"> • 220/66kV, 315 MVA, ICTs – 2 nos. • 220kV ICT bays – 2 nos. • 66kV ICT bays – 2 nos. • 220kV line bays – 2 nos. (at B3-OSS-1 for termination of B3-OSS-1 – Mahuva Onshore PS (GIS) 220 kV two nos. (3 core) cables) • 66kV line bays – 10 nos.
2.	B3-OSS-1 – Mahuva Onshore PS (GIS) 220 kV two nos. (3 core) cables (45 km- under sea cable of about 35 km & under ground cable of about 10 km) alongwith associated line bays at both ends (with capacity of 300 MVA/ckt at nominal voltage) with 1x50 MVAR switchable line reactors at B3-OSS-1 end on each cable	<ul style="list-style-type: none"> • Cable length ~45 km • 220 kV, 50MVAR switchable line reactors at OSS-1 end – 2 nos. • Switching equipment for 220 kV, 50 MVAR switchable line reactors at OSS-1 end – 2 nos.

Note:

- TSP of Vataman S/s (Vataman Transmission Ltd.) shall provide space for augmentation works at Vataman S/s
- Vataman switching S/s has been planned through LILO of Lakadia-Vadodara 765 kV D/c line at Vataman under Khavda Ph-III (7 GW) and is presently under implementation by POWERGRID (under TCB) with implementation schedule of Dec'25 (SCOD).
- Distances indicated above are tentative and may change based on actual survey.

Implementation timeframe: Mar-2028

Estimated Cost: Rs. About Rs 6900 Crs {Onshore Portion: 2200, Offshore Portion: 4700}

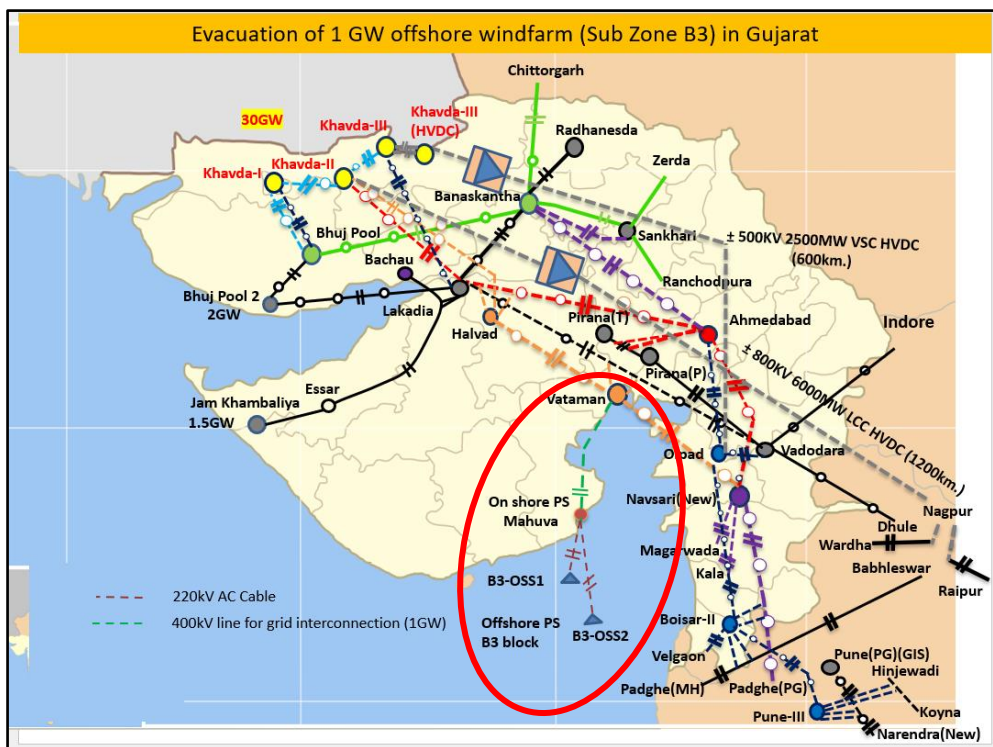

Figure 5-55-9: Schematic representation of Tr. System for Offshore Wind Zone Phase-1 (500 MW VGF off the coast of Gujarat for Subzone B3)

5.4.2 Maharashtra

(a) Network Expansion scheme in Western Region to cater to Pumped storage potential near Talegaon (Pune)

Hon'ble MoP, GOI has identified a potential of more than 10GW Pumped Storage Plants (PSPs) in the area between Boisar, Nashik & Pune. In this regard, application for Connectivity has been received from M/s Tata Power Company for Bhivpuri PSP of 1150MW with estimated commissioning date as 01.01.2028. M/s TPC is also planning PSP at Shirwata with 1980MW capacity.

Considering the huge PSP potential in the area, which are likely to tie up power for pumping mode from RE generation projects located far away, it was proposed to establish a 765/400 kV substation near South Kalamb. Further, considering huge demand of Mumbai area, space for HVDC terminal is proposed to be kept for future use.

Subsequently, applications for drawal of 1400MW power were received from Data Centre Loads in Mumbai area with start date of 01.01.2027. The applications are under process and Connectivity is being proposed at South Kalamb S/s to address the requirement of drawal of such huge quantum of power. The scheme was discussed and approved under TBCB in the 20th NCT meeting held on 25.06.2024 with implementation time frame of 24 months or 01.01.2027 (i.e., start date of GNA of DC loads), whichever is later. The detailed scope of work is given below:

Detailed scope of work:

Sl. No.	Scope of the Transmission Scheme	Capacity /km
1.	<p>Establishment 2x1500 MVA, 765/400 kV Substation near South of Kalamb with 2x330 MVAR, 765 kV bus reactor and 2x125 MVAR, 420 kV bus reactor.</p> <p><u>Future provision (space for):</u></p> <ul style="list-style-type: none"> ▪ 765/400 kV ICT along with bays- 10 Nos. (2 Nos. on Sec-I, 4 Nos. in Sec-II & 4 Nos. on Sec-III) ▪ 765 kV line bays along with switchable line reactors – 6 Nos. (4 Nos. on Sec-II & 2 Nos. on Sec-III) ▪ 765 kV Bus Reactor along with bay: 4 Nos. (2 Nos. on Sec-II & 2 No. on Sec-III) ▪ 765 kV Sectionalizer: 2 -sets ▪ 400 kV line bays along with switchable line reactors– 20 Nos. (6 Nos. on Sec-I, 6 Nos. on Sec-II & 8 Nos. on Sec-III) ▪ 400/220 kV ICT along with bays -4 Nos. (on 400 kV Sec-III: 2 Nos. on 220 kV Sec-I & 2 Nos. on 220 kV Sec-II) ▪ 400 kV Bus Reactor along with bays: 4 Nos. (2 Nos. on Sec-II & 2 No. on Sec-III) ▪ 400 kV Sectionalization bay: 2- set ▪ 220 kV line bays: 8 Nos. (4 Nos. on Sec-I & 4 Nos. on Sec-II) ▪ 220 kV Sectionalization bay: 1 set ▪ 220 kV BC and TBC: 2 Nos. ▪ Establishment of 6000 MW, \pm 800 kV South Kalamb (HVDC) [LCC] terminal station (4x1500 MW) along with associated interconnections with 400 kV HVAC Switchyard (2x1500 MW on 400 kV Sec-I & 2x1500 MW on 400 kV Sec-II) & all associated equipment (incl. filters)/bus extension, etc. 	<ul style="list-style-type: none"> • 765/400 kV, 1500 MVA ICT – 2 Nos. (7x500 MVA single phase units including one spare ICT Unit) • 765 kV ICT bays – 2 Nos. • 400 kV ICT bays – 2 Nos. • 765 kV Line bays – 4 Nos. • 330 MVar, 765 kV bus reactor- 2 Nos. (7x110 MVAR single phase Reactors including one spare Unit for bus /line reactor) • 765 kV Bus reactor bay – 2 Nos. • 125 MVar, 420 kV reactor- 2 Nos. • 400 kV Reactor bay- 2 Nos. • 400 kV line bays - 2 Nos. (for interconnection of PSP)
2.	<p>LILO of Pune-III – Boisar-II 765 kV D/c line at South Kalamb S/s with associated bays at South Kalamb S/s</p>	<ul style="list-style-type: none"> • LILO Route length: 40 km (160 ckm.) • The Pune-III – Boisar-II 765 kV D/c line is of Hexa Zebra configuration and LILO shall be of similar conductor configuration
3.	<p>Installation of 1x240 MVar switchable line reactor on each ckt at South Kalamb end of Boisar-II – South Kalamb 765 kV D/c line (formed after above LILO)</p>	<ul style="list-style-type: none"> • 1x240 MVar, 765 kV switchable line reactor – 2 Nos. • Switching equipment for 765 kV line reactor – 2 Nos. • Spare Reactor (1-ph, 1x80 MVar) unit at 765/400 kV South Kalamb S/s

Implementation time frame: 24 months from the date of SPV transfer (or) 01.01.2027 whichever is earlier.

Estimated Cost: Rs. 1663 Crs.

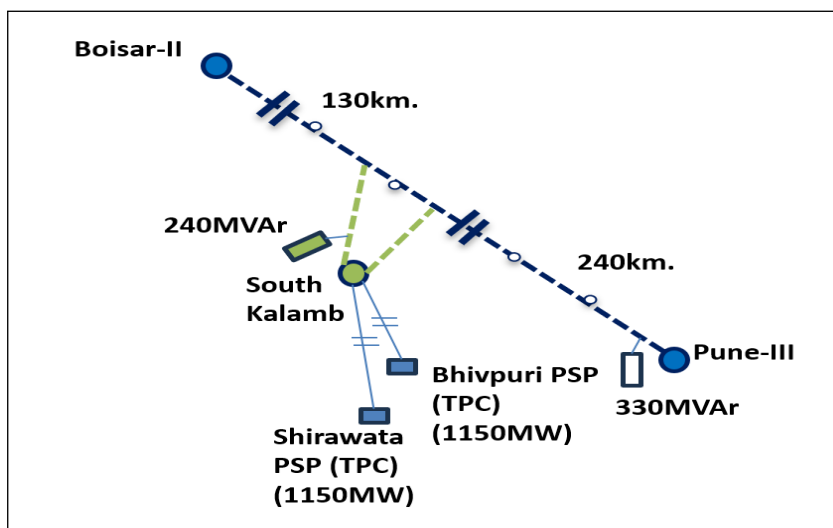

Figure 5-55-10: Schematic of Tr. Scheme for interconnection of PSPs in Maharashtra.

5.4.3 Madhya Pradesh

(a) Network Expansion Scheme in Vindhyachal complex of Madhya Pradesh

Connectivity application (No. 2200000400) by NTPC Ltd (1600 MW) was received in the month of Dec'23. After several round of deliberations, the transmission scheme for grant of connectivity under GNA to NTPC Ltd. for Singrauli-III 2x800MW units was finalised in 30th Consultation Meeting for Evolving Transmission Schemes in Western Region held on 02.07.2024 as per details given below:

Dedicated Transmission System for Connectivity

- Shifting of existing Vindhyachal V – Vindhyachal IV 400kV D/c (twin) line to Singrauli-III so as to form Vindhyachal V – Singrauli III 400kV D/c (twin) line . (Under scope of NTPC Ltd.)
- Installation of 1x125MVAR, 420kV Bus Reactor at Singrauli III 400kV Bus (Under scope of NTPC Ltd.)
- Vindhyachal IV – Vindhyachal PS 400kV 2nd D/c (quad) line (of CWRTL) shall be disconnected at Vindhyachal-IV and shall be shifted to Singrauli-III to form Singrauli III – Vindhyachal PS 400kV D/C (Quad) line. (Under scope of NTPC Ltd.)
- Singrauli III – Vindhyachal PS 400kV S/c (Quad) line (on S/c tower) (with minimum capacity of 2100MVA per ckt at nominal voltage). (Under scope of NTPC Ltd.) along with associated bay at Singrauli-III end. The line will be terminated in a 400kV bay at Vindhyachal PS which would be made available after bypassing works at Vindhyachal PS as mentioned under Common Transmission System Augmentation for grant of GNA

Note: Vindhyachal III – Vindhyachal V may be kept normally open and may be closed under contingency conditions based on feedback from GRID-INDIA.

Common Transmission System Augmentation for grant of GNA: Under ISTS

Sl. No.	Scope of the Transmission Scheme	Capacity /km
1.	Vindhyachal IV – Vindhyachal PS 400kV 1st D/c (quad) line (of POWERGRID) and Vindhyachal PS – Sasan 400kV D/c (twin) line (of POWERGRID) to be bypassed at Vindhyachal PS and interconnected with each other at outskirts of Vindhyachal PS (Under scope of ISTS) so as to form Vindhyachal IV (2x500MW) – Sasan 400kV D/c line.	NA

Note:

1. This line will be exclusively used for 2x500MW Vindhyachal-IV evacuation.
2. With this arrangement, 4 nos. 400kV bays shall become available at Vindhyachal PS. Out of the same, 1 no. shall be utilized for termination of Singrauli III – Vindhyachal PS 400kV S/c (Quad) line of NTPC and balance 3 nos. bays may be utilized as per requirement in future.

Implementation time-frame: 01.03.2028 (as per start date of connectivity requested by NTPC for Singrauli-III expansion project, for which above transmission system is required as Common Transmission System Augmentation for grant of connectivity under GNA)

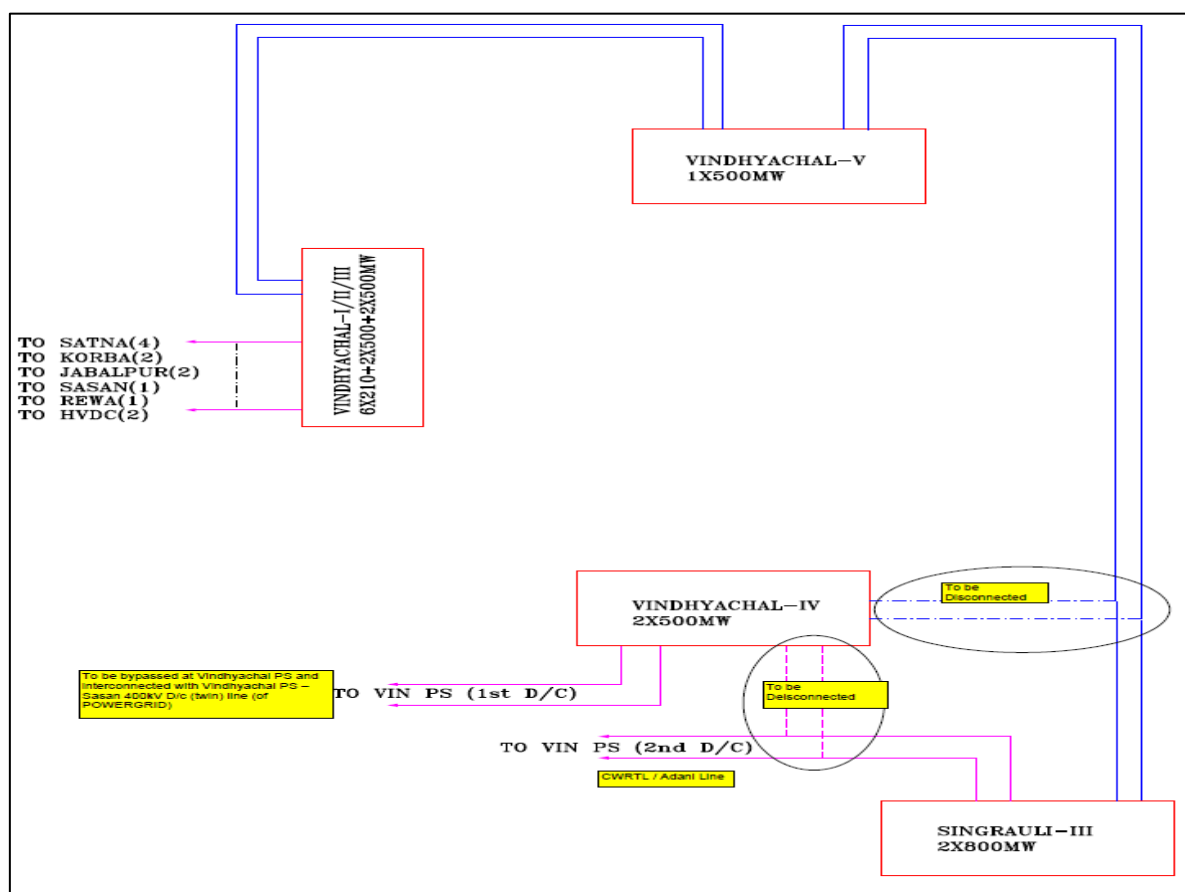

Figure 5-55-11: Schematic of Network Expansion Scheme in Vindhyachal Complex

(b) Transmission System for enabling RE interconnection at Mandsaur S/s

765/400/220kV Mandasaur PS was planned with 3x1500MVA, 765/400kV & 5x500MVA, 400/220kV ICTs to enable evacuation of power from 2 GW Wind Potential. The scheme is currently under implementation by Mandasaur Transmission Limited (subsidiary of POWERGRID). M/s Sprng Green Energy 2 Pvt. Ltd. (SGE2PL) has applied for Connectivity at Mandasaur S/s vide application no. 2200000824 for 600MW RE power injection from 31.12.2029. The subject scheme is planned to enable the Connectivity of M/s INGEPL.

Detailed scope of work:

Sl. No.	Scope of the Transmission Scheme	Capacity /km
1.	1 No. 400kV bay at Mandasaur S/s for RE Interconnection (Sprng Green Energy 2 Pvt. Ltd. (SGE2PL) (2200000824) for 600MW)	400kV line bay – 1 No.

Implementation time-frame: 31.12.2029 as per start date of connectivity under GNA requested by applicant.

Estimated cost: Rs. 17.28 Crs.

(c) Transmission System for enabling RE interconnection at Neemuch S/s

2x500MVA, 400/220kV Neemuch S/s is an existing S/s of POWERGRID, which was planned to enable RE evacuation of up to 1GW in Neemuch area of MP., 2 nos. of 220kV bays were also implemented as a part of the pooling station were allotted to RUMSL’s Solar Park in Neemuch.

Subsequently, an application (No. 2200000709) for Connectivity for 300MW was received from M/s ACME Cleantech Solutions Pvt. Ltd. The subject scheme was planned to enable the injection of power from ACSPL’s 300MW Solar Park.

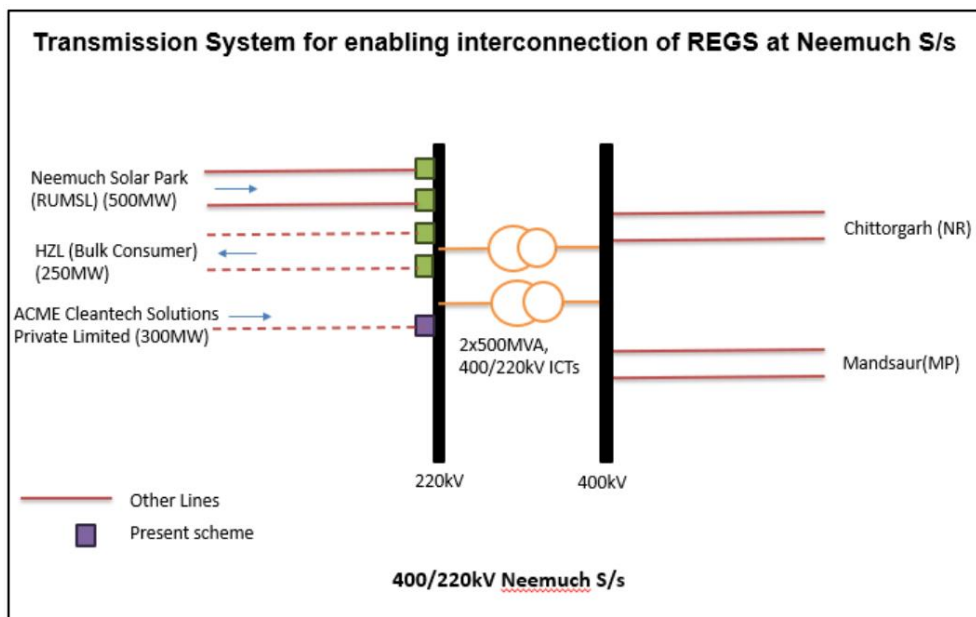

Figure 5-55-12: Schematic of Neemuch S/s representing the Tr. System for enabling RE interconnection

Detailed scope of work:

Sl. No.	Scope of the Transmission Scheme	Capacity /km
1.	1 No. 220kV bay at Neemuch S/s for RE Interconnection (ACME Cleantech Solutions Private Limited (2200000709) for 300MW)	220kV line bay – 1 No.

Implementation time-frame: 18 months or 31.12.2025 (as per start date requested by applicant), whichever is later

Estimated cost: Rs. 5.57 Crs.

(d) Transmission system for Evacuation of Power from RE Projects in Neemuch (1000 MW) SEZ in Madhya Pradesh-Phase II

The Government of India has set a target for establishing 500GW non-fossil generation capacity by 2030, out of which 1GW SEZ has been identified at Neemuch for which 2x500MVA, 400/220kV Neemuch PS is already commissioned by POWERGRID.

In view of applications received for cumulative capacity of 1770MW at Neemuch PS till Jun-24, it was found prudent to expand the substation to its full capacity so as to accommodate applications being received beyond 1GW at Pachora PS. Accordingly, the present scheme is planned which shall enable evacuation of additional 1000MW power from RE projects in Neemuch SEZ (i.e. 1000 MW beyond 1000MW) in Madhya Pradesh. The scheme was agreed in the 31st CMTS-WR held on 02.08.2024 and is currently under approval. The detailed scope of work is given below.

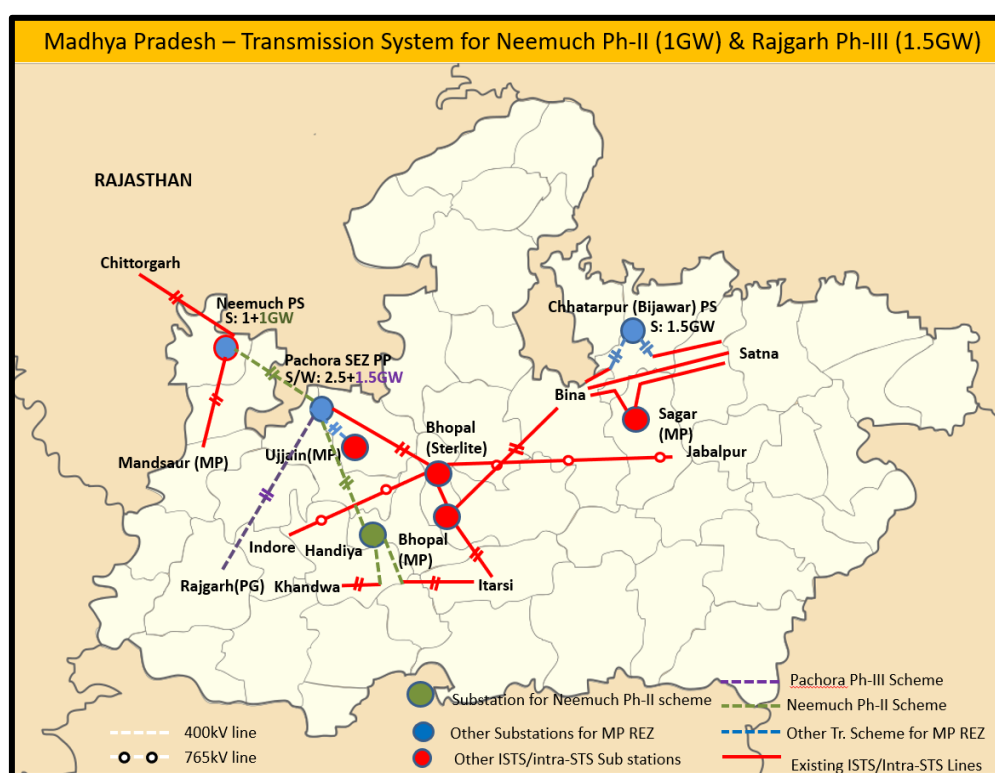

Figure 5-55-13: Schematic for Tr. system for Evacuation of Power from RE Projects in Madhya Pradesh

Detailed scope of work:

Sl. No.	Scope of the Transmission Scheme	Capacity
1.	Creation of New 220kV Bus Section-II at Neemuch PS with Augmentation of transformation capacity by 3x500MVA, 400/220kV ICTs (3 rd , 4 th & 5 th) at Neemuch S/s along with associated bays.	<ul style="list-style-type: none"> • 500MVA 400/220kV ICT – 3 No. • 400kV ICT bay – 3 No. • 220kV ICT bay – 3 No. (on Sec-II) • 220kV Bus Sectionalizer bays – 1 set • 220kV BC & TBC – 1 No. each
2.	4 Nos. 220kV Line bays at Neemuch PS for RE interconnection	220kV Bays – 4 Nos. on Sec-II
3.	Neemuch PS – Pachora PS 400kV D/c line (Quad ACSR/ AAAC/ AL59 Moose equivalent) along with 50MVA Sw LR on each ckt at both ends	<ul style="list-style-type: none"> • Line length: 190km. • 400kV bays: 4 nos. (2 at Neemuch PS & 2 at Pachora PS) • 420kV, Sw LRs: 4 nos. (2 at Neemuch PS & 2 at Pachora PS) • Switching equipment for 400 kV line reactor – 4 Nos. (2 at Neemuch PS & 2 at Pachora PS)
4.	Establishment of 2x500MVA, 400/220kV S/s at Handiya with 2x125MVA 420kV Bus Reactors Future provision (space for): <ul style="list-style-type: none"> • 400 kV line bays along with switchable line reactors– 6 Nos. (Sec-II) • 400/220 kV ICT along with bays - 4 Nos. (1 No. on Sec-I & 3 Nos. on Sec-II) • 400 kV Bus Reactor along with bays: 2 Nos. (Sec-II) • 220 kV line bays: 8 No. (on Sec-II) • 400 kV Sectionalization bay: 1 set • 220 kV Sectionalization bay: 1 set • 220 kV TBC & BC: 1 No. 	<ul style="list-style-type: none"> • 400/220kV ICTs: 2 Nos. • 400kV ICT Bays: 2 Nos. • 220kV ICT Bays: 2 Nos. • 400kV Line bays: 6 Nos. • 220 kV line bays for MPPTCL – 8 Nos. • 125 MVA, 420 kV Bus reactor – 2 Nos • 400 kV Bus reactor bay: 2 Nos. • 220 kV TBC bay – 1 no. • 220 kV BC bay – 1 no.
5.	Pachora PS – Handiya 400kV D/c line (Quad ACSR/ AAAC/ AL59 Moose equivalent) along with associated bays at Pachora PS end and 50MVA Sw LR on each ckt at both ends	<ul style="list-style-type: none"> • Line length: 190km. • 400kV bays: 2 nos. (at Pachora PS) • 420kV, Sw LRs: 4 nos. (2 at Handiya & 2 at Pachora PS) • Switching equipment for 400 kV line reactor – 4 Nos. (2 at Handiya & 2 at Pachora PS)
6.	LILO of Khandwa (PG) – Itarsi (PG) 400kV D/c (Twin Moose) line at Handiya S/s	<ul style="list-style-type: none"> • LILO route length: 22 km (88 ckm) • The Khandwa (PG) – Itarsi (PG) 400kV D/c line is of Twin Moose configuration and LILO shall be of similar conductor configuration

Sl. No.	Scope of the Transmission Scheme	Capacity
7.	Installation of 1x125 MVAR, 420 kV bus reactor (2 nd) at Neemuch PS	<ul style="list-style-type: none"> • 125 MVAR, 420 kV Bus reactor – 1 No. • 400 kV Bus reactor bay: 1 No.

Note:

- TSP of Neemuch & Pachora PS shall provide space for above scope of work

Implementation time-frame: 24 months from the date of SPV transfer.

Estimated cost: Rs. 2240 Crs.

(e) Transmission system for Evacuation of Power from RE Projects in Rajgarh (1500 MW) SEZ in Madhya Pradesh-Phase III

The Government of India has set a target for establishing 500GW non-fossil generation capacity by 2030, out of which 2.5GW REZ potential has been identified at Rajgarh (MP). Transmission schemes for evacuation of the identified 2.5GW RE power were planned in two phases as detailed below.

- I. Phase-I (1.5GW) involves establishment of Pachora PS with 3x500 MVA 400/220kV ICTs and Pachora PS – Bhopal 400kV D/c line which was implemented by M/s G R Infraprojects Ltd.
- II. Phase-II (1GW) involves ICT augmentation (4th, 5th & 6th) Pachora PS along with Pachora PS – Ujjan (MPPTCL) 400kV D/c line which is presently under implementation by M/s G R Infraprojects Ltd. with SCOD of 14.02.2026.

However, in view of applications received for cumulative capacity of 3813MW at Pachora PS till Jun-24, it is prudent to expand the substation to its full capacity so as to accommodate applications being received beyond 2.5GW at Pachora PS.

Accordingly, the present scheme is planned which shall enable evacuation of additional 1500MW power from RE projects in Rajgarh SEZ (i.e. 1500 MW beyond 2500MW) in Madhya Pradesh. The scheme was agreed in the 31st CMTS-WR held on 02.08.2024 and is currently under approval. The detailed scope of work is given below.

Detailed scope of work:

Sl. No.	Scope of the Transmission Scheme	Capacity
1.	Creation of New 220kV Bus Section (3 rd) with 220kV Bus Sectionaliser and 400/220kV, 3x500MVA ICT augmentation (7 th , 8 th & 9 th) at Pachora PS terminated on 220kV Bus Section (3 rd)	<ul style="list-style-type: none"> • 500MVA 400/220kV ICT – 3 No. • 400kV ICT bay – 3 No. • 220kV ICT bay – 3 No. (on Sec-III) • 220kV Bus Sectionaliser bays – 1 set • 220kV BC & TBC – 1 No. each
2.	4 nos. 220kV line bays for RE Interconnection on Bus Section (3 rd)	<ul style="list-style-type: none"> • 4 Nos. on Sec-III

Sl. No.	Scope of the Transmission Scheme	Capacity
3.	Pachora PS – Rajgarh(PG) 400 kV D/c line (Quad ACSR/ AAAC/ AL59 Moose equivalent) along with associated bays at both ends (180km.) and 50MVAR Sw LR on each ckt at both ends	<ul style="list-style-type: none"> Line length: 180km. 400kV bays: 4 nos. (2 at Rajgarh (PG) & 2 at Pachora PS) 420kV, Sw LR: 4 nos. (2 at Rajgarh (PG) & 2 at Pachora PS) Switching equipment for 400 kV line reactor – 4 Nos. (2 at Rajgarh (PG) & 2 at Pachora PS)
4.	Installation of 1x125 MVAR, 420 kV bus reactor at Pachora PS (400kV Bus Section-II)	<ul style="list-style-type: none"> 125 MVAR, 420 kV Bus reactor – 1 No. 400 kV Bus reactor bay: 1 No.

Note:

- TSP of Rajgarh (PG) & Pachora PS shall provide space for above scope of work

Implementation time-frame: 24 months from the date of SPV transfer.

Estimated cost: Rs. 1079 Crs.

(f) Transmission System for evacuation of power from Mahan Energen Limited Generating Station in Madhya Pradesh

2x600MW Thermal Power Station of M/s Mahan Energen Limited (MEL) located in Singrauli, Madhya Pradesh is already connected with ISTS. M/s MEL was granted Connectivity for 1100MW under the CERC Connectivity/ LTA Regulations, 2009 and power was being evacuated through implementation of SPS. Subsequently, M/s MEL has applied for Connectivity for remaining 100MW vide application no. 2200000224.

To evacuate the total 1200MW capacity of power reliably without SPS, the “Transmission System for evacuation of power from Mahan Energen Limited Generating Station in Madhya Pradesh” is proposed with the scope of work as detailed below. The scheme was deliberated and agreed in the WRPC meeting held on 27.03.2024 with an implementation timeframe of 30 months. Subsequently, the scheme was approved in the 20th NCT meeting held on 25.06.2024 and was recommended for implementation under TBCB.

Detailed scope of work:

Sl. No.	Scope of the Transmission Scheme	Capacity /km
1.	Mahan (existing bus) – Rewa PS (PG) 400 kV D/c (Quad ACSR/AAAC/AL59 moose equivalent) line	Route Length: ~110 km.
2.	2 Nos. 400 kV bays at Rewa PS (PG) for termination of Mahan (existing bus) – Rewa PS (PG) 400 kV D/c line (Quad ACSR/AAAC/AL59 moose equivalent)line	400 kV bays: 2 Nos.

Note:

- 2 Nos. 400 kV line bays at MEL (existing) shall be under the scope of MEL.

- POWERGRID to provide space at Rewa PS (PG) for scope at Sl. 2.

Implementation timeframe: 30 months from the date of SPV transfer.

Estimated Cost: Rs. 558 Crs. (Approx.)

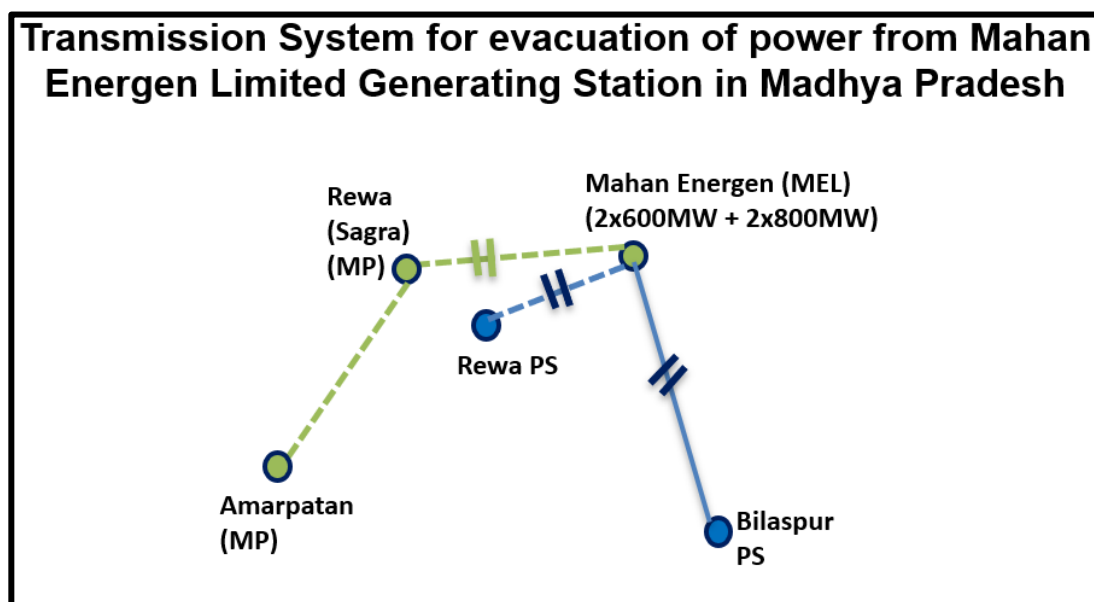

Figure 5-55-14: Transmission scheme for evacuation of power from 1200MW Mahan TPS & 1600MW Mahan extension plant.

5.4.4 Chhattisgarh

(a) Transmission System for evacuation of power from Vedanta's Thermal Power Station (1200MW) in Sakti, Chhattisgarh

M/s Vedanta applied for Connectivity for 1200MW at Raigarh (Kotra) S/s for Athena 2x600MW Power Project. However, there is no margin for injection left at Raigarh(Kotra) Substation for injection of power as any injection at Raigarh(Kotra) S/s leads to N-1 non-compliance of 765/400kV ICTs [especially under Raigarh-Pugalur HVDC reverse power flow scenario (3000MW reversal)] and there are severe fault level issues at the substation.

In view of the same, connectivity has been agreed at Raigarh(PG) S/s. However, as there is no space left at Raigarh(PG) S/s for 2 nos. 400kV bays, it was agreed that Vedanta shall connect to Raigarh(PG) S/s by interconnecting the already existing 400kV D/c line upto Raigarh(Kotra) with Raigarh (Kotra) – Raigarh (PG) 400kV D/c line (which is presently kept normally open to control fault level at Raigarh (Kotra) & Raigarh(PG) substations).

Considering that the 400kV bays at Raigarh (PG) are rated at 2000A (i.e. 1385MVA), they shall be sufficient to cater to 1200MW capacity of Vedanta's Athena project, without the need for upgradation. However, since Raigarh (Kotra) – Raigarh (PG) 400kV D/c line is twin moose line, a portion of it which would be utilized by M/s Vedanta would need to be reconducted to meet the evacuation requirement of 1200MW capacity (matching with capacity of Vedanta's Athena project). Based on feedback from M/s Vedanta regarding the feasibility of implementation, the scheme was planned with the following scope of work.

Detailed scope of work:

Sl. No.	Scope of the Transmission Scheme	Capacity /km
1.	Reconductoring of a portion of Raigarh (Kotra) – Raigarh (PG) 400kV D/c line [i.e. from Raigarh(PG) to Termination point near Raigarh(PG) at which Vedanta’s 400kV D/c line is being terminated into Raigarh (Kotra) – Raigarh (PG) 400kV D/c line so as to form Vedanta – Raigarh(PG) 400kV D/c line]* with twin HTLS conductor (with minimum capacity of 1200MW per ckt at nominal voltage (~1.3km.))	1.3km. reconductoring
2.	Associated jumpering arrangement at termination point so as to establish Vedanta – Raigarh(PG) 400kV D/c line (with minimum capacity of 1200MW per ckt at nominal voltage)	-

Implementation time-frame: 6 months from award to implementing agency

Estimated cost: Rs. 3.61 Crs.

(b) 400kV line bays at Champa for Interconnection of NTPC LARA STPP STAGE-II (1600MW) Project

6x1500MVA, 765/400kV Champa PS is an existing substation of POWERGRID with 3x1500MVA, 765/400kV ICTs on each bus section.

Lara stage-I STPP (2x800 MW) of NTPC was granted connectivity through Lara STPP I – Raigarh (Kotra) PS 400kV D/c line and Long Term Access (LTA) through Lara STPP I – Champa PS (Section-I) 400kV D/c (quad) line for transfer of 1500MW power from the Lara-I project to various beneficiaries in WR. The entire 1500MW quantum has now been converted into deemed GNA. KSK 3x600MW units are connected at Champa PS on the 400kV Bus Section-II.

Application for Connectivity for 1600MW was received from NTPC for LARA STPP STAGE-II Project (2x800MW) which was allowed for injection of power from the 400kV Bus Section-II of Champa PS (where KSK 3x600MW Units are connected). The present scheme involves 2 nos. 400kV bays at Champa PS (Bus Section B, with KSK 3x600MW Units) for termination of 400kV D/c (Quad) line from Lara STPP St-II generation switchyard to Champa PS.

Detailed scope of work:

Sl. No.	Scope of the Transmission Scheme	Capacity /km
1.	2 nos. 400kV bays at Champa PS (Bus Section A, with KSK 3x600MW Units) for termination of Lara STPP St-II Generation Switchyard – Champa 400kV D/c (Quad) line	400kV line bays: 2 Nos. (on Bus Section A, with KSK 3x600MW Units)

Implementation time-frame: 01.05.2027 (as per start date of connectivity requested by NTPC Ltd.)

Estimated cost: Rs. 18.57 Crs.

(c) Scheme to control high voltages at Champa PS (on Bus Section-A, where Lara-I project is connected)

6x1500MVA, 765/400kV Champa PS is an existing substation of POWERGRID with 3x1500MVA, 765/400kV ICTs on each bus section. During the deliberations made in the 29th CMETS-WR held on 03.06.2024, GRID-INDIA has put forth the observation of high voltages on the bus section-I of both 765kV & 400kV buses of Champa PS after bus sectionalisation due to inadequate shunt reactive power compensation.

As a result of this, Champa-Kurukshetra HVDC bipole-I is also being blocked for controlling the voltages during off-peak hours. Hence there is a requirement of sufficient reactive power compensation at Champa PS on Section-I of 765kV & 400kV buses (where Lara-I is connected) for reliable operation of Champa-Kurukshetra HVDC bipoles.

Detailed scope of work:

Sl. No.	• Scope of the Transmission Scheme	• Capacity
1.	<ul style="list-style-type: none"> • Installation of 1x240MVA, 765kV Bus Reactor & 1x125MVA, 420kV Bus Reactor at Champa PS (<i>On Bus section-A where Lara-I project is connected</i>) 	<ul style="list-style-type: none"> • 1x240MVA, 765kV Bus Reactor – 1 No. • 765kV BR bay – 1 No. • 1x125MVA, 420kV Bus Reactor – 1 No. • 400kV BR bay – 1 No.

Note:

- TSP of Champa PS shall provide space for above work.

Implementation time-frame: 18 months

Estimated cost: Rs. 79.28 Crs.

(d) Associated Transmission System for grant of Connectivity under GNA to Sipat STPS Stage-III (1x800MW)

The existing 2x1000MVA, 765/400kV ICTs at Sipat STPS are seen to be overloaded in system studies in Solar Max Scenario even under reduced generation at Sipat STPS. Hence, Augmentation of transformation capacity at Sipat STPS by 1x1500MVA, 765/400kV ICT (3rd) shall be required to alleviate the constraint. NTPC has applied for Connectivity at NTPC Sipat for injecting 800MW thermal power. The same was deliberated in the 30th CMETS-WR and it was agreed for augmentation of transformation capacity at Sipat STPS with the following scope of work subject to feasibility of Augmentation

Detailed scope of work:

Sl. No.	Scope of the Transmission Scheme	Capacity
1.	Augmentation of transformation capacity at Sipat STPS by 1x1500MVA, 765/400kV ICT (3rd)	1500MVA, 765/400kV ICT-1 No. (4x500MVA Incl. spare) 765kV ICT Bay: 1 No. 400kV ICT Bay: 1 No.

Note:

- NTPC to provide space for above works
- The ICT is to be placed at 765kV Bus Section-II by utilising bay no. 23 at 765kV side and Bay no. 21 on 400kV side. For both these bays, tie bay is existing and Main bay is to be constructed. Further, Connection of 400kV side of ICT-3 with associated 400kV bay requires crossing under 765kV Sipat-Bilaspur-1, 2 and 3 lines through BPIs at 8m equipment height or suitable gantry arrangement.

Implementation timeframe: 31.01.2028

Page intentionally left blank

Chapter 6: Southern Region

Southern Region is connected to Western and Eastern Regions through high capacity 765kV AC links, Back-to-Back HVDC and Bi-pole HVDC links. The thermal generating stations of Southern Region are predominantly concentrated in the States of Tamil Nadu, Karnataka, Andhra Pradesh and Telangana. The States of Tamil Nadu, Karnataka and Andhra Pradesh are rich in RE comprising of large scale Solar & Wind potential. Southern part of Karnataka (Bangalore), Kerala and Central part of Telangana (Hyderabad) has high demand and less internal generation. With the continuous increase in demand and limited conventional generation availability, Southern Region imports power from NEW Grid during peak demand period whereas it exports power to NEW Grid during high RE scenario / off peak demand period.

6.1 Power Supply Scenario as on Aug'24

As on Aug, 2024 total Installed Capacity (IC) of Southern Region was about 131 GW and the peak demand was about 67 GW. Southern Region has touched the maximum export of about 9 GW and maximum import of about 21 GW. The state-wise breakup of installed capacity and peak demand is summarised below.

Table 6-1: SR Installed Capacity and Peak Demand as on Aug'24

(All Fig in GW)

State	Generation							Grand Total	Peak Demand
	Fossil			Non Fossil					
	Thermal	Gas	Total	Nuclear	Hydro	RES	Total		
Andhra Pradesh	12.3	3.8	16.1	0.1	1.7	9.5	11.3	27.4	13.7
Telangana	10.9	0.8	11.7	0.1	2.5	5.3	7.9	19.6	15.6
Karnataka	10.5	0.0	10.5	0.7	3.6	18.6	22.9	33.4	17.0
Kerala	2.5	0.5	3.1	0.4	1.9	1.6	3.8	6.9	5.6
Tamil Nadu	14.9	1.0	16.0	1.4	2.2	21.1	24.8	40.7	20.8
NLC and Lakshadweep	0.1	0.0	0.1	0.0	0.0	0.0	0.0	0.1	0.0
Puducherry	0.3	0.0	0.3	0.1	0.0	0.1	0.1	0.4	0.5
Central unallocated	2.1	0.0	2.1	0.5	0.0	0.0	0.5	2.6	0.0
SR	53.5	6.3	59.8	3.3	11.8	56.1	71.2	131.0	67.0

Source: CEA monthly report

From above, it can be concluded that share of non-fossil fuel based generation capacity in total present installed capacity (IC) of 131 GW is 71.2 GW i.e. 54% of total IC. This share would further increase in envisaged scenario of 2029-30 timeframe.

6.2 Envisaged Power Supply Scenario by 2029-30

As per the 20th EPS, Southern Region demand for 2029-30 timeframe is expected to increase to about 97 GW. As per the inputs received from various stakeholders, total installed capacity of Southern Region for 2029-30 is expected to be about 229 GW. The state wise bifurcation of installed capacity and peak demand is summarized below.

Table 6-2: SR Installed Capacity and peak demand (2029-30)

(All Fig in GW)

State	Generation									Peak Demand
	Fossil			Non Fossil				ESS	Grand Total	
	Thermal	Gas	Total	Nuclear	Hydro	RES	Total			
Andhra Pradesh	7.1	0.2	7.3	0.0	2.9	9.6	12.6	1.4	21.2	22.1
Telangana	9.2	0.0	9.2	0.0	0.9	2.7	3.6	1.6	14.4	24.2
Karnataka	7.7	0.4	8.1	0.0	4.3	13.5	17.8	0.0	25.8	20.3
Kerala	0.0	0.4	0.4	0.0	2.4	0.2	2.5	0.0	2.9	6.4
Tamil Nadu	10.5	0.6	11.0	0.0	1.9	18.7	20.6	0.9	32.6	25.8
Puducherry	0.0	0.0	0.0	0.0	0.0	0.0	0.0	0.0	0.0	0.6
Central	15.3	0.0	15.3	5.8	0.0	0.0	5.8	0.0	21.1	
IPP	3.2	0.0	3.2	0.0	0.0	92.9	92.9	15.1	111.2	
SR	52.9	1.5	54.4	5.8	12.4	137.6	155.8	19.0	229.2	97.4

From above, it is observed that growth in installed capacity of Southern Region is majorly from non-fossil fuel based generation resources. Share of non-fossil fuel based generation capacity in total present installed capacity (IC) has increased from 54% to 76%.

Compound annual growth rate in peak demand of Southern Region from present time-frame to 2029-30 is around 7.3 %. The state wise peak demand growth is given below :

Table 6-3: Increase in Peak Demand of Various States of SR

(All Fig in MW)

State	Peak Demand (MW)			
	Present	2029-30	Difference	% CAGR
Andhra Pradesh	13712	22091	8379	10.0%
Telangana	15573	24215	8642	9.2%
Karnataka	16985	20254	3269	3.6%
Kerala	5631	6431	800	2.7%
Tamil Nadu	20784	25764	4980	4.4%
Puducherry	549	624	75	2.6%
SR	66986	97440	30454	7.8%

Therefore, annual growth rate in peak demand is maximum for Andhra Pradesh (10 %) and minimum for Puducherry (2.6 %).

6.3 Load Generation Balance for 2029-30 Timeframe

In chapter-3, all India Load Generation Balance (LGB) for identified nine scenarios was prepared as per the methodology finalized in consultation with CTU, CEA and Grid-India (Erstwhile GRID INDIA). This section elaborates the Southern Region Load Generation Balance (LGB) for 2029-30 time-frame. For Southern Region also, three points on the daily load curve i.e. Solar max (afternoon), Peak load (evening) and Off-peak load (night) for three seasons viz. Monsoon (August), Summer (June) and Winter (February) have been considered.

Load generation balance has been prepared considering the generation despatch factors as mentioned below for the 9 scenarios. Further, thermal generators have been despatched as per the merit order.

Table 6-4: Southern Region Generation Dispatch and Demand Factors

Scenario No & Name	Generation Dispatch Factors						Demand Factors
	Hydro	Nuclear	Solar	Wind	ESS	Gas	
1-Aug Solar Max	40%	80%	80%	55%	-100%	0%	67%
2-Aug Peak Load	70%	80%	0%	75%	60%	50%	68%
3-Aug Night Off Peak	40%	80%	0%	65%	40%	50%	49%
4-Jun Solar Max	40%	80%	85%	55%	-100%	0%	78%
5-Jun Peak Load	70%	80%	0%	75%	50%	50%	69%
6-Jun Night Off Peak	40%	80%	0%	65%	1%	50%	51%
7-Feb Solar Max	20%	80%	90%	0%	-100%	0%	93%
8-Feb Peak Load	40%	80%	0%	20%	100%	50%	68%
9-Feb Night Off Peak	20%	80%	0%	0%	40%	30%	59%

6.4 ISTS Network Expansion Schemes Evolved from Feb/Mar'24 to Jul'24

Various transmission schemes have been discussed/finalized in the Consultative Meeting for Evolution of Transmission System of Southern Region (CMETS-SR) from Feb/Mar 2024 to July 2024. Brief of all such deliberated transmission schemes are tabulated below:

Table 6-5: Details of the schemes evolved in SR

Sl. No	Name of the Transmission Scheme	Expected Timeframe	Type of scheme	Quantum (MW)	Tentative Cost (in Cr.)
Karnataka					
1.	Augmentation of transformation capacity by 1x500 MVA (3rd), 400/220kV ICT at Yelahanka 400/220kV GIS S/s in Karnataka	2025-26	SS	-	52
2.	Augmentation of transformation capacity by 2x500 MVA (9th & 10th), 400/220kV ICTs at Tumkur (Pavagada) 400/220kV Pooling Station in	2025-26	RE	1000	118

Sl. No	Name of the Transmission Scheme	Expected Timeframe	Type of scheme	Quantum (MW)	Tentative Cost (in Cr.)
	Karnataka and Implementation of 1 nos. of 220kV line bay at Tumkur (Pavagada) 400/220kV PS				
3.	Augmentation of transformation capacity by 1x500 MVA (3rd), 400/220kV ICT at Bidadi S/s in Karnataka	2025-26	SS	-	56
4.	Augmentation of transformation capacity by 4x500 MVA, 400/220kV ICTs (5th – 8th) at Davanagere PS	2026-27	RE	2000	204
5.	Augmentation of transformation capacity by 3x500 MVA, 400/220kV ICTs (6th - 8th) and 1x1500 MVA,765/400kV ICT (4th) at Bidar PS	2026-27	RE	1500	288
Andhra Pradesh					
1.	Implementation of 3 nos. of 400kV line bays at Ananthapuram PS for integration of RE generation projects	2026-27	RE	-	46
2.	Transmission system strengthening at Kurnool-III PS for integration of additional RE generation projects	2026-27	RE	4500	2886
3.	Conversion of 80 MVAR FLR to SLR on Vijayawada – Nellore 400kV D/c line (Line-2) at Nellore as per 44th SRPC and 42nd TCC	2025-26	SS	-	-
4.	Augmentation of transformation capacity with 400/220kV, 1x500 MVA ICT (4th) at Nagarjunasagar 400/220kV substation	2026-27	SS	-	-
5.	Transmission System for integration of Kurnool-IV REZ in Andhra Pradesh (Phase-I)	2026-27	RE	4500	5550
6.	Transmission System for proposed Green Hydrogen / Green Ammonia projects in Kakinada area, Andhra Pradesh	2027-28	GH	3000	1015
7.	Transmission System for integration of Anantapur-II REZ in Andhra Pradesh (Phase-I)	2026-27	RE	4500	4679
Tamil Nadu					
1.	Transmission System for 0.5 GW Offshore wind farm (Phase-I) in Tamil Nadu	2028-29	RE	500	6242
2.	Implementation of 1 nos. of 230kV line bay at Karur 400/230kV PS for integration of RE generation project (M/s Nannai Solar Park Private Ltd.)	2025-26	RE	-	6
3.	Transmission system for proposed Green Hydrogen / Green Ammonia projects in Tuticorin area	2027-28	GH	3000	2617

*RE – Renewable Energy; SS- System Strengthening; GH – Green Hydrogen;

Details of the schemes are reproduced below state-wise:

6.4.1 Karnataka

(a) Augmentation of transformation capacity by 1x500 MVA (3rd), 400/220kV ICT at Yelahanka 400/220kV GIS S/s in Karnataka

Presently, 2x500 MVA, 400/220kV are existing at Yelahanka GIS. KPTCL vide letter dated 28.03.2024 has communicated that residential load of about 250 MW is coming up at Dr. Shivaram Karanath BDA layout near Ganigarahalli in Bengaluru. KPTCL is proposing to establish a new 220kV substation in that area by interconnecting with Yelahanka 400/220kV GIS S/s through 1200sqmm UG cable for meeting the demand. Keeping in view of the upcoming 250 MW load, KPTCL opined that additional 1x500 MVA, 400/220kV ICT (3rd) at Yelahanka GIS is required considering the N-1 contingency criteria. Accordingly, they had requested for augmentation of 1x500 MVA (3rd), 400/220kV ICT at Yelahanka 400/220kV GIS S/s.

Accordingly, augmentation of transformation capacity by 1x500 MVA (3rd), 400/220kV ICT at Yelahanka 400/220kV GIS S/s was discussed and agreed in the 32nd CMETS-SR held on 28.06.2024.

Estimated Cost : Rs. 52 Crore

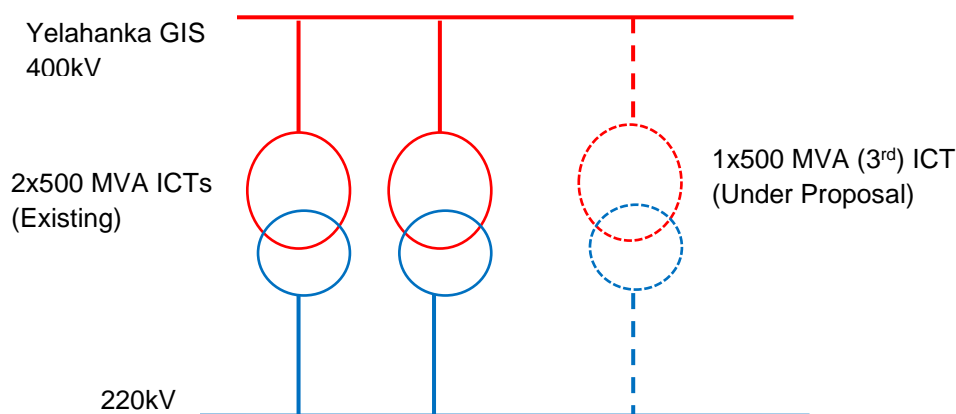

(b) Augmentation of transformation capacity by 2x500 MVA (9th & 10th), 400/220kV ICTs at Tumkur (Pavagada) 400/220kV Pooling Station in Karnataka and Implementation of 1 nos. of 220kV line bay at Tumkur (Pavagada) 400/220kV PS for providing Connectivity to RE generation project

Presently, Tumkur (Pavagada) PS is under operation with 6x500 MVA, 400/220kV ICTs and 2x500 MVA (7th & 8th), 400/220kV ICTs at Tumkur (Pavagada) are under implementation and expected by Aug'25. The Connectivity of 3350 MW has been granted to RE projects at Tumkur (Pavagada) PS.

During the 25th CMETS-SR held on 28.11.2023, Connectivity of 200 MW has been agreed for grant to M/s TEQ Green Power XVIII Pvt. Ltd. at 220kV level with 1 nos. of 220kV bay. The above applicant have requested for implementation of 220kV bay at Tumkur (Pavagada) PS under ISTS with start date as 30.06.2026. The same was also agreed in the 28th CMETS-SR held on 29.02.2024. Further, M/s KSPDCL has submitted application for enhancement of Connectivity for 300 MW at Tumkur (Pavagada) PS (from under operation 2050 MW solar project to 2350 MW) as Renewable Power Park Developer which was discussed in the 26th CMETS-SR held on 29.12.2023. During the meeting, it was decided that due to non-availability of margins for grant of additional connectivity at Tumkur (Pavagada) PS, the connectivity has been granted at Tumkur-II PS.

In 26th CMETS-SR, KSPDCL mentioned that they have taken initiatives towards acquisition of land for augmentation of Tumkur (Pavagada) PS and requested for grant of connectivity for 300 MW at Tumkur (Pavagada PS) instead of Tumkur-II PS. CTU informed that at present, for grant of connectivity, there is no margin in existing Tumkur (Pavagada) PS. After getting confirmation towards land acquisition and possibility of Tumkur (Pavagada) PS augmentation, the same shall be considered for grant of connectivity. KSPDCL vide letter dated 31.05.2024 informed that they have initiated few actions subsequent to the 26th CMETS-SR meeting viz. identification of land required for proposed expansion and fixation of land rate by Deputy Commissioner, consent from the farmers to sell the land etc.

Accordingly, as land is available for expansion of the pooling station and for optimal utilization of the transmission system, augmentation of transformation capacity by 2x500 MVA (9th & 10th), 400/220kV ICTs at Tumkur (Pavagada) 400/220kV Pooling Station in Karnataka was discussed and agreed in the 32nd CMETS-SR held on 28.06.2024. The details of the scheme is as below:

Sl. No.	Scope of the Transmission Scheme	Capacity /km	Schedule	Est. Cost (crs.)
1	Augmentation of transformation capacity by 2x500 MVA (9 th & 10 th), 400/220kV ICTs at Tumkur (Pavagada) 400/220kV Pooling Station	<ul style="list-style-type: none"> • 2x500 MVA, 400/220kV ICTs • 400kV ICT bay – 2 Nos. • 220kV ICT bay – 2 Nos. 	21 months	112
2	Additional land of about 100 m (width) x 540 m (length) on right side of the Tumkur (Pavagada) PS for expansion of Tumkur (Pavagada) PS with 2 nos. of additional 500 MVA ICTs & 220 kV line bays	The total land of about 13 Acres 22 Guntas is required for the proposed expansion and land rate has been fixed by the Deputy Commissioner at Rs. 2.62 Cr. (Rs. 19.35 L per Acre) as communicated by KSPDCL vide letter dated 31.05.2024		
3	Implementation of 1 nos. of 220kV line bay at Tumkur(Pavagada)	1 no. 220kV line bay at Tumkur(Pavagada) 400/220kV PS for termination of dedicated	30.06.26	6

Sl. No.	Scope of the Transmission Scheme	Capacity /km	Schedule	Est. Cost (crs.)
	400/220kV PS for providing Connectivity to RE generation project	line of M/s TEQ Green Power XVIII Pvt. Ltd.		
			Total	118

Estimated Cost: Rs. 118 Crore

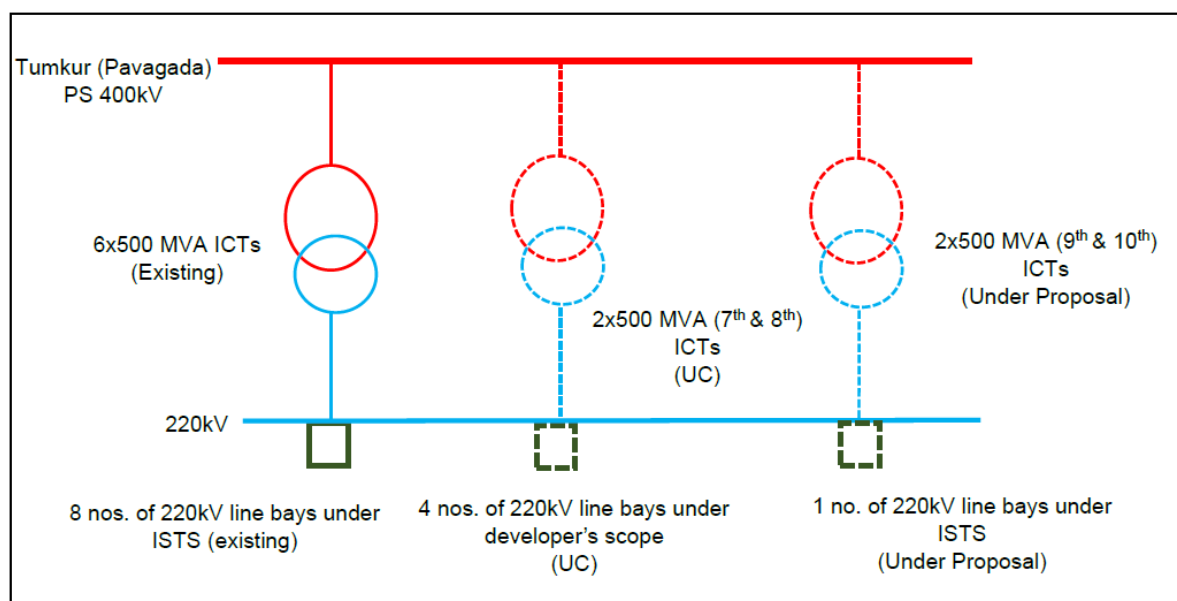

Above transmission scheme has been forwarded to NCT vide CTU letter dated 26.07.2024. The scheme was discussed and agreed for implementation under RTM route with implementation schedule of 21 months in the 21st NCT held on 06.08.2024.

(c) Augmentation of transformation capacity by 1x500 MVA (3rd), 400/220kV ICT at Bidadi S/s in Karnataka

During the 213th OCC meeting of SRPC held on 10.04.2024 requirement of additional ICT at Bidadi S/s due to continuous overloading / N-1 violation of existing ICTs was discussed. During the meeting it was opined that KPTCL have to plan / augment the downstream network to match the power evacuation. The matter was also deliberated during the 216th OCC meeting of SRPC held on 10.07.2024, wherein it was decided that matter may be taken up in the next CMETS-SR meeting for deliberations.

Accordingly, augmentation of transformation capacity by 1x500 MVA (3rd), 400/220kV ICT at Bidadi S/s in Karnataka was discussed and agreed in the 33rd CMETS-SR held on 25.07.2024.

(d) Augmentation of transformation capacity by 4x500 MVA, 400/220kV ICTs (5th – 8th) at Davanagere PS

Presently, 4x1500 MVA, 765/400kV and 4x500 MVA, 400/220 kV Davanagere / Chitradurga Pooling Station is being established as part of ‘Transmission system for integration of Davanagere/ Chitradurga REZ’. The transmission scheme has been recommended for implementation through TBCB route in the 18th NCT held on 05.03.2024 and Gazette Notification published on 15.03.2024 by Ministry of Power with implementation time frame of 24 months. Considering the bidding process timeline, the scheme is expected tentatively by July/Aug’2026. Total Connectivity already granted/ agreed for grant at Davanagere PS is 2340 MW. Therefore, in 32nd CMETS-SR, held on 28.06.2024, for grant of Connectivity, augmentation of 2x500 MVA, 400/230 kV (5th & 6th) ICT were proposed and same was agreed. Subsequently, applications for additional connectivity corresponding to 775 MW capacity has been received upto June 2024. Therefore, total connectivity granted/ agreed for grant/ under consideration shall be 3115 MW. Accordingly, total 8x500 MVA, 400/220 kV transformation capacity is required at Davanagere PS for grant of connectivity for 3115 MW (considering N-1 contingency criteria).

Accordingly, augmentation of transformation capacity by 4x500 MVA, 400/220 kV ICTs (5th – 8th) at Davanagere PS in Karnataka was discussed and agreed in the 33rd CMETS-SR held on 25.07.2024

Estimated cost : Rs. 204 crs

(e) Augmentation of transformation capacity by 3x500 MVA, 400/220kV ICTs (6th - 8th) and 1x1500 MVA,765/400kV ICT (4th) at Bidar PS

CTU informed that Bidar PS is being established with 3x1500 MVA, 765/400kV and 5x500 MVA, 400/220 kV ICTs as part of ‘Transmission Scheme for Solar Energy Zone in Bidar (2500 MW), Karnataka’. Details of transmission system as per Annexure-V. The transmission scheme is under implementation and expected by 09.02.2026. Total Connectivity already granted / agreed for grant at Bidar PS is 2500 MW. Therefore, in 32nd CMETS-SR, held on 28.06.2024, CTU informed that for grant of Connectivity, augmentation of 1x500 MVA, 400/220 kV (6th) ICT is required and same was agreed. Subsequently, applications for additional connectivity corresponding to 600 MW capacity has been received upto June 2024. Therefore, total connectivity granted / agreed for grant / under consideration shall be 3100 MW. Accordingly, for grant of connectivity (considering N-1 contingency criteria) total 8x500 MVA, 400/220kV and 4x1500 765/400kV ICTs shall be required at Bidar PS.

Accordingly, augmentation of transformation capacity by 3x500 MVA, 400/220 kV ICTs (6th – 8th) and 1x1500 765/400kV ICT (4th) at Bidar PS in Karnataka was discussed and agreed in the 33rd CMETS-SR held on 25.07.2024.

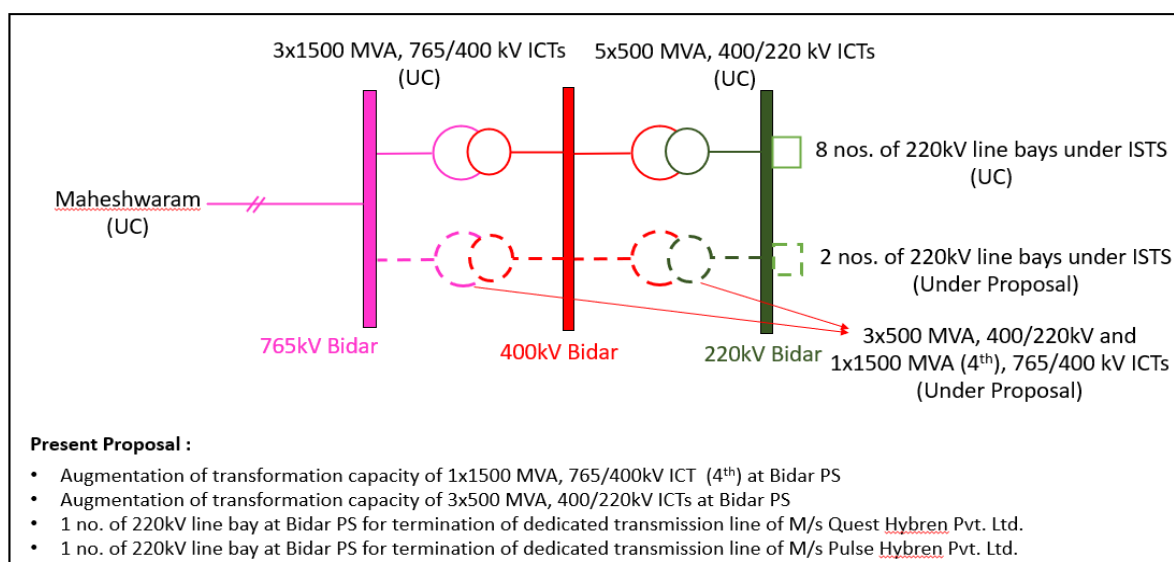

Estimated cost : Rs. 288 crs.

Above transmission scheme has been forwarded to NCT vide CTU letter dated 20.08.2024.

6.4.2 Andhra Pradesh

(a) Implementation of 3 nos. of 400kV line bays at Ananthapuram PS for integration of RE generation projects

Presently, Ananthapuram 400/220kV PS is under implementation by POWERGRID through TBCB route and is expected by Sept'25. Connectivity of about 1055 MW at 220kV and 2710 MW at 400kV has been granted at Ananthapuram to various RE generation projects. 12 nos. of 220kV line bays are already implementation. Connectivity of 1710 MW has been granted to M/s Renew Vikram Shakti Pvt. Ltd. at 400kV level with 2 nos. of 400kV bays in the 23rd CMETS-SR held on 29.09.2023. Further, Connectivity of 1000 has been granted to M/s ABC Cleantech Pvt. Ltd. at 400kV level with 1 nos. of 400kV bay in the 25th CMETS-SR held on 28.11.2023. The above RE generation projects have requested for implementation of 400kV bay at Ananthapuram PS under ISTS. The details are as below:

Sl. No.	Description of Transmission Element	Scope of work	Schedule
1	2 nos. of 400kV line bays at Ananthapuram PS for Connectivity to M/s Renew Vikram Shakti Pvt. Ltd.	400kV line bays – 2 Nos.	31.03.26
2	1 no. of 400kV line bay at Ananthapuram PS for Connectivity to M/s ABC Cleantech Pvt. Ltd.	400kV line bays – 1 Nos.	31.03.26

The scheme was deliberated and agreed in the 28th CMETS-SR held on 29.02.2024.

Estimated cost: Rs. 46 Crore

400kV bays at Ananthapuram for integration of RE generation projects

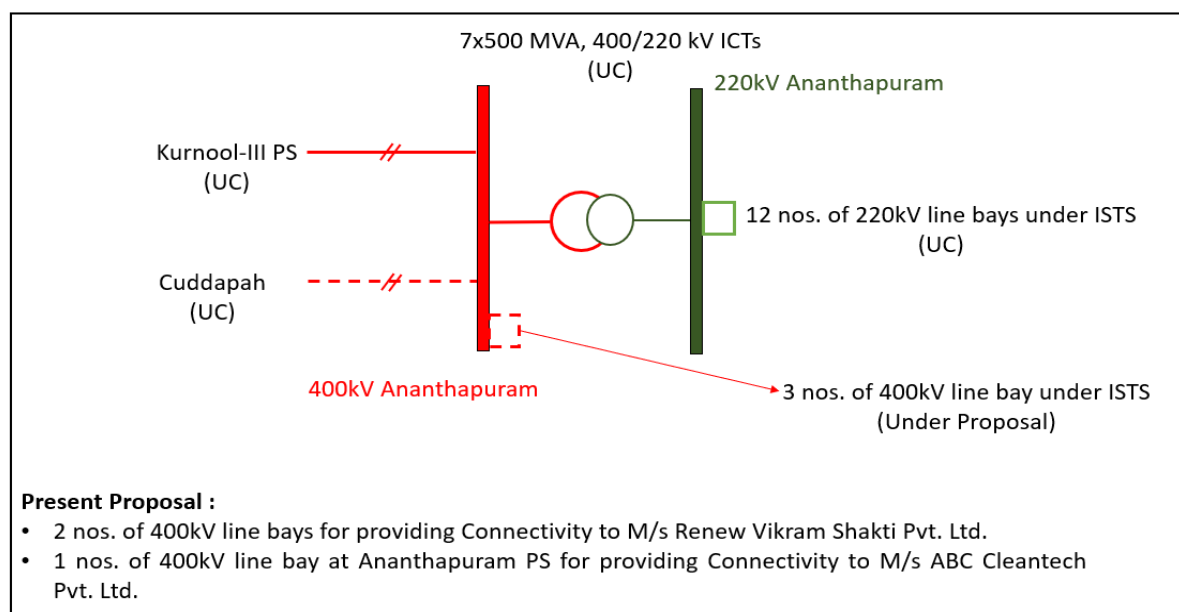

Above transmission scheme viz., Implementation of 3 nos. of 400kV line bays at Ananthapuram PS for integration of RE generation projects has been allocated to POWERGRID under RTM vide CTU letter dated 22.03.2024.

(b) Transmission system strengthening at Kurnool-III PS for integration of additional RE generation projects

Presently, Kurnool-III 765/400/220kV PS is under implementation by POWERGRID through RTM route and is expected by Nov'24. Further, for optimal utilisation of the pooling station, space provision for integration of additional 4.5 GW has been kept at Kurnool-III. The broad scheme is as below:

- Establishment of 765/400/220kV 3x1500 MVA, 9x500 MVA Kurnool-III PS
- Kurnool-III PS – Kurnool(new) 765 kV D/c line
- Kurnool-III PS – Maheshwaram (PG) 765 kV D/c line

Connectivity of about 2320 MW (1720 MW at 220kV level & 600 MW at 400kV level) have already been granted at Kurnool-III PS with the above under implementation transmission system. Further, CTU has received additional connectivity applications for 3770 MW (Solar: 3650 MW & Wind: 120 MW) seeking connectivity at Kurnool-III in the month of Nov'23. With this, the total connectivity quantum at Kurnool-III became about 6090 MW (1990 MW at 220kV level & 4100 MW at 400kV level). However, Kurnool-III PS is being implemented with 3x1500 MVA, 765/400kV transformation capacity. Therefore, grant of connectivity for additional 3770 MW shall require expansion of Kurnool-III PS and further transmission lines for evacuation of power from Kurnool-III PS. CTU also received additional connectivity applications for 1650 MW (PSP: 1250 MW & Solar: 400 MW) at Kurnool-III PS in the month of Jan'24. With this, the total connectivity

quantum at Kurnool-III shall be about of 7740 MW (2390 MW at 220kV level & 5350 MW at 400kV level).

Accordingly, the following transmission system was deliberated in the 28th CMETS-SR held on 29.02.2024 and agreed for integration of additional RE generation projects and grant of Connectivity at Kurnool-III PS under the CERC GNA Regulations.

- Augmentation of transformation capacity of 3x1500 MVA, 765/400kV ICTs at Kurnool-III PS
- Kurnool-III PS – Chilakaluripeta 765 kV D/c line (about 260 km) with 240 MVAr switchable line reactors at both ends

CTU also received additional connectivity application for 260 MW at Kurnool-III PS in the month of Feb'24. Connectivity corresponding to 7740 MW have been granted / agreed for grant at Kurnool-III PS. However, for evacuation of additional power from Kurnool-III REZ and Ananthapuram REZ, 1x1500 MVA, 765/400 kV ICT (7th) is also required. Accordingly, augmentation of 1x1500 MVA 765/400kV ICT (7th) at Kurnool-III PS was proposed in the 29th CMETS-SR held on 28.03.2024. With this, the total connectivity quantum granted / agreed for grant at Kurnool-III PS shall be about of 8000 MW (2650 MW at 220kV level & 5350 MW at 400kV level).

The Connectivity have been granted for 600 MW to M/s Adani Renewable Energy Forty Two Ltd. for its PSP generation project at 400kV level with 2 nos. of 400kV line bays (under ISTS scope) for termination of its dedicated transmission line in the 23rd CMETS-SR held on 29.09.2023. Similarly, Connectivity have been granted for 3500 MW (800 MW & 3x900 MW) to M/s Indosol Solar Pvt. Ltd. for its Solar Power Park at 400kV level with 4 nos. of 400kV line bays (under ISTS scope) for termination of its dedicated transmission lines in the 26th CMETS-SR held on 29.12.2023. Similarly, Connectivity have been agreed for grant for 1250 MW to M/s Adani Renewable Energy Fifty One Ltd. for its PSP generation project at 400kV level with 2 nos. of 400kV line bays (under ISTS scope) for termination of its dedicated transmission lines in the 28th CMETS-SR held on 29.02.2024. Accordingly, total 8 nos. of 400kV line bays are required to developed under ISTS for termination of dedicated transmission lines from the above generation projects.

The Transmission Scheme “Transmission system strengthening at Kurnool-III PS for integration of additional RE generation projects” was forwarded to SRPC for views on 08.04.2024. The scheme was deliberated in the 51st SRPC meeting held on 15.05.2024. SRPC vide letter dated 22.05.2024 has forwarded the views of Southern Region constituents.

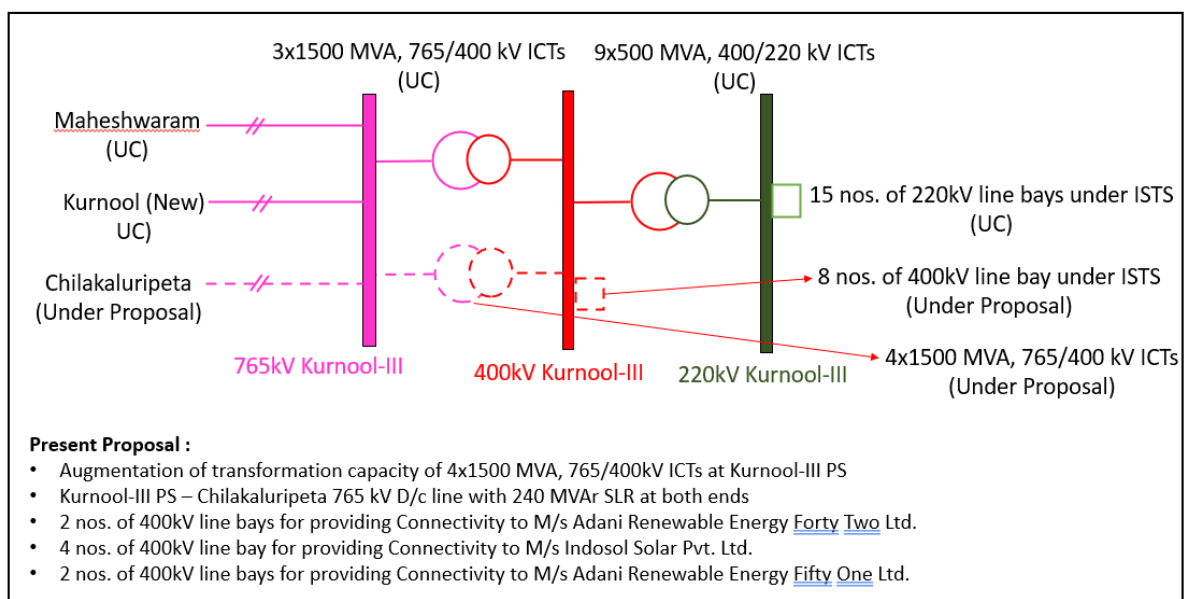

Package	Scope of the Transmission Scheme	Capacity /km	Schedule	Est. Cost (crs.)
A	Augmentation of transformation capacity of 3x1500 MVA, 765/400kV ICTs at Kurnool-III PS	<ul style="list-style-type: none"> • 3x1500 MVA, 765/400kV ICT • 765kV ICT bay – 3 Nos. • 400kV ICT bay – 3 Nos. • 400kV Bus Sectionaliser – 1 Set 	24 months	2650
	Kurnool-III PS – Chilakaluripeta 765 kV D/c line with 240 MVA _r switchable line reactors at both ends	<p>~ 260 km</p> <ul style="list-style-type: none"> • 765kV line bays – 2 nos. (at Kurnool-III PS) • 765kV line bays – 2 nos. (at Chilakaluripeta) • 765 kV, 240 MVA_r SLR at Kurnool-III PS – 2 nos. (6x80 MVA_r units) • 765 kV, 240 MVA_r SLR at Chilakaluripeta – 2 nos. (6x80 MVA_r units) 		
B	2 nos. of 400kV line bays at Kurnool-III PS for termination of dedicated transmission line of M/s Adani Renewable Energy Forty Two Ltd.	<ul style="list-style-type: none"> • 400kV line bays – 2 Nos. 	30.06.26	110
	4 nos. of 400kV line bay at Kurnool-III PS for termination of dedicated transmission lines of M/s Indosol Solar Pvt. Ltd.	<ul style="list-style-type: none"> • 400kV line bays – 1 Nos. 	24 months	
		<ul style="list-style-type: none"> • 400kV line bays – 1 Nos. • 400kV line bays – 2 Nos. 	24 months 31.03.27	

Package	Scope of the Transmission Scheme	Capacity /km	Schedule	Est. Cost (crs.)
	2 nos. of 400kV line bays at Kurnool-III PS for termination of dedicated transmission line of M/s Adani Renewable Energy Fifty One Ltd.	<ul style="list-style-type: none"> 400kV line bays – 2 Nos. 	31.12.27	
C	Augmentation of 1x1500 MVA 765/400kV ICT (7 th) at Kurnool-III PS	<ul style="list-style-type: none"> 1x1500 MVA, 765/400kV ICT 765kV ICT bay – 1 Nos. 400kV ICT bay – 1 Nos. 	24 months	126
			Total	2886

Above transmission scheme viz., Transmission system strengthening at Kurnool-III PS for integration of additional RE generation projects has been forwarded to NCT vide CTU letter dated 30.05.2024. The scheme was discussed and agreed for implementation through TBCB route in the 20th NCT held on 25.06.2024.

(c) Conversion of 80 MVAR FLR to SLR on Vijayawada – Nellore 400kV D/c line (Line-2) at Nellore as per 44th SRPC and 42nd TCC

POWERGRID vide letter dated 04.10.2023 informed that replacement of 50 MVAR line reactor at Nellore end on Vijayawada – Nellore 400kV D/c line (Line-2) with 80 MVAR under AddCap was approved in the 44th SRPC meeting held on 04.11.2022. Further, it was decided that line reactors would be made switchable for use of bus reactors wherever technically feasible / space available. Accordingly, POWERGRID requested that conversion of 80 MVAR fixed line reactor at Nellore end on Vijayawada – Nellore 400kV D/c line (Line-2) to switchable line reactor along with NGR and its bypassing scheme in the CMETS-SR meeting.

Accordingly, conversion of 80 MVAR fixed line reactor at Nellore end on Vijayawada – Nellore 400kV D/c line (Line-2) to switchable line reactor along with NGR and its bypassing scheme was agreed in the 32nd CMETS-SR held on 28.06.2024.

(d) Augmentation of transformation capacity with 400/220kV, 1x500 MVA ICT (4th) at Nagarjunasagar 400/220kV substation

The proposal for augmentation of transformation capacity with 400/220kV, 1x500 MVA ICT (4th) at Nagarjunasagar 400/220kV substation was agreed in the Joint Study meeting of SR constituents held from 2nd to 4th May, 2024 at Hyderabad. During the Joint Study meeting, it was agreed that a joint site visit with participation from CTU, SRPC, POWERGRID, APTRANSCO and TGTRANSCO may be planned to explore the space availability for 220kV ICT bay at APTRANSCO switchyard along with interconnection with POWERGRID switchyard. Accordingly, for assessing space availability for 220kV

ICT bay at Nagarjunasagar, a joint site visit was held on 24th June, 2024 comprising officials from CEA, SRPC, POWERGRID, APTRANSCO and TGTRANSCO.

During the Joint study visit 2 options were identified and could not be finalized. After detailed deliberations, it was decided that the matter may be put up to the higher forum for further deliberations and finalization.

The proposal was deliberated in the 33rd CMETS-SR held on 25.07.2024 and 31.07.2024 and after detailed deliberations, the augmentation of 1x500 MVA ICT (4th) at Nagarjunasagar was agreed. However, options for implementation of the ICT shall be finalized in the meeting with CEA.

(e) Transmission System for integration of Kurnool-IV REZ in Andhra Pradesh

Govt. of India has set a target of 500 GW generation capacity from non-fossil fuel resources by 2030. In this direction, MNRE has identified addition of 86 GW RE Potential in the State of Andhra Pradesh, Telangana, Karnataka and Tamil Nadu (Offshore) in Southern Region. Out of the identified (86 GW) RE Potential in Southern Region, 51 GW has been identified in the State of Andhra Pradesh (Ananthapur– 20 GW, Kurnool – 23 GW & Kadapa – 8 GW).

A comprehensive transmission system for integration of 51 GW RE Potential in Andhra Pradesh have been identified by CEA and a report on Transmission System for Integration of over 500 GW RE Capacity has been published by CEA on 07.12.2022. The details of district wise potential is as below.

District	Potential (GW)		Total (GW)	Maximum Dispatch (GW)	BESS (GW)	Evacuation System (GW)
	Wind	Solar				
Anantapur	10	10	20	15	5	10
Kurnool	8	15	23	18	6	12
Kadapa	0	8	8	8	3	5
Total	18	33	51	41	14	27

Presently, Connectivity of about 7740 MW (2390 MW at 220kV level & 5350 MW at 400kV level) has been granted / agreed for grant at Kurnool-III PS. Similarly, Connectivity of about 3765 MW (1055 MW at 220kV level & 2710 MW at 400kV level) has been granted / agreed for grant at Ananthapuram PS. Keeping above in view, it is prudent to take up the implementation of Kurnool-IV PS and Anantapur-II PS for integration of RE generation projects in Kurnool and Anantapur areas. The above transmission schemes were deliberated in the 28th CMETS-SR held on 29.02.2024 wherein it was decided that a physical joint study may be carried out for finalization of the transmission system for Kurnool-IV and Ananthapuram-II.

Accordingly, Joint Study meeting of Southern Region Constituents was held from 2nd to 4th May, 2024 at Hyderabad wherein following transmission system was finalized for integration of RE generation projects at Kurnool-IV in Andhra Pradesh.

Transmission System for Integration of Kurnool-IV (Near Aspiri) REZ (for 7.5 GW)

Phase-I (4.5 GW)

- Establishment of 4x1500 MVA, 765/400 & 4x500 MVA, 400/220 kV Kurnool-IV Pooling Station near Kurnool, Andhra Pradesh along with 2x330 MVAR (765 kV) bus reactors at Kurnool-IV PS (1.5 GW injection at 220 kV level and 3 GW injection at 400 kV level)
- + 300 MVAR STATCOM at Kurnool-IV, 2x125 MVAR MSR
- Kurnool-IV – Bidar 765kV D/c line (about 330 kms) with 330 MVAR SLR at both end on both circuits
- Kurnool-IV – Kurnool-III PS 765 kV D/c line (about 150 kms) with 240 MVAR SLR at Kurnool-IV end on both circuits
- Augmentation of 1x1500 MVA, 765/400 kV ICT at C’Peta

Phase-II (3 GW)

- Augmentation of 2x1500 MVA, 765/400 & 6x500 MVA, 400/220 kV Kurnool-IV Pooling Station (2 GW injection at 220 kV level and 2 GW injection at 400 kV level)
- Establishment of 3x1500 MVA, 765/400 kV Veltoor-II Station with 2x330 MVAR (765 kV) bus reactors
- LILO of Kurnool-IV – Bidar 765kV D/c line at Veltoor-II (about 60 kms)
- Veltoor-II – Veltoor TS 400 kV D/c (quad) line (about 60 kms)
- Veltoor-II – Udandpur 400 kV D/c (quad) line (about 30 kms)
- LILO of Vijayawada-Nellore 400 kV D/c line at C’Peta (about 20 kms)

The above transmission schemes were deliberated in the 32nd CMETS-SR held on 28.06.2024 wherein it was agreed that initially Kurnool-IV Phase-I may be taken up for implementation and Kurnool-IV Phase-II may be reviewed as per the observations of the SR constituents. It was also agreed that LILO of Vijayawada-Nellore 400 kV D/c line at C’Peta (about 20 kms) may be considered in Phase-I.

The detailed scheme is as below:

Sl. No.	Scope of the Transmission Scheme	Capacity /km
1.	<p>Establishment of 4x1500 MVA, 765/400 & 4x500 MVA, 400/220 kV Kurnool-IV Pooling Station near Kurnool, Andhra Pradesh along with 2x330 MVAR (765 kV) bus reactors at Kurnool-IV PS with provision of two (2) sections of 4500 MVA each at 400kV level</p> <p>Future Space Provisions:</p> <ul style="list-style-type: none"> • 765/400kV, 1500 MVA, ICTs – 2 nos. • 765kV ICT bays – 2 nos. 	<ul style="list-style-type: none"> • 765/400kV, 1500 MVA, ICTs – 4 nos. (13x500 MVA incl. 1 spare unit) • 765kV ICT bays – 4 nos. • 400kV ICT bays – 4 nos. • 400/220kV, 500 MVA, ICTs – 4 nos. • 400kV ICT bays – 4 nos. • 220kV ICT bays – 4 nos.

Sl. No.	Scope of the Transmission Scheme	Capacity /km
	<ul style="list-style-type: none"> • 400kV ICT bays – 2 nos. • 400/220kV, 500 MVA, ICTs – 14 nos. • 400kV ICT bays – 14 nos. • 220kV ICT bays – 14 nos. • 765kV line bays – 8 nos. (with provision for SLR) • 400kV line bays – 12 nos. (with provision for SLR) • 220kV line bays – 20 nos. • 220kV Bus Sectionalizer : 2 sets • 220 kV Bus Coupler (BC) Bay – 2 nos. • 220 kV Transfer Bus Coupler (TBC) Bay – 2 nos. • 400kV Bus Sectionalizer : 1 set 	<ul style="list-style-type: none"> • 765kV line bays – 4 nos. (at Kurnool-IV PS for termination of Kurnool-IV – Bidar and Kurnool-IV – Kurnool-III 765kV D/c lines) • 765 kV, 330 MVA Bus Reactor – 2 nos. • 765 kV Bus Reactor bays – 2 nos. • 220kV line bays – 6 nos. • 220kV Bus Sectionalizer : 1 set • 220 kV Bus Coupler (BC) Bay – 2 nos. • 220 kV Transfer Bus Coupler (TBC) Bay – 2 nos.
2.	Kurnool-IV – Bidar 765kV D/c line (about 330 kms) with 330 MVAR SLR (convertible) at both ends on both circuits	<p style="text-align: center;">~ 330 km</p> <ul style="list-style-type: none"> • 765kV line bays – 2 nos. (at Bidar PS) • 765 kV, 330 MVA SLR at Kurnool-IV PS – 2 nos. (7x110 MVA inc. 1 switchable spare unit for both bus reactor and line reactor) • 765 kV, 330 MVA SLR at Bidar PS – 2 nos. (7x110 MVA inc. 1 switchable spare unit)
3.	Kurnool-IV – Kurnool-III PS 765 kV D/c line (about 150 kms) with 240 MVAR SLR (convertible) at Kurnool-IV end on both circuits	<p style="text-align: center;">~ 150 km</p> <ul style="list-style-type: none"> • 765kV line bays – 2 nos. (at Kurnool-III PS) • 765 kV, 240 MVA SLR at Kurnool-IV PS – 2 nos. (7x80 MVA inc. 1 switchable spare unit)
4.	\pm 300 MVAR STATCOM at Kurnool-IV PS along with 2x125 MVA MSR	<ul style="list-style-type: none"> • 400 kV bay – 1 no.
5.	Augmentation of 1x1500 MVA, 765/400 kV ICT (3 rd) at C’Peta	<ul style="list-style-type: none"> • 765/400kV, 1500 MVA, ICT – 1 no. • 765kV ICT bays – 1 no. • 400kV ICT bays – 1 no.
6.	LILO of Vijayawada-Nellore 400 kV D/c line at C’Peta (about 20 kms)	<p style="text-align: center;">~ 20 km</p> <ul style="list-style-type: none"> • 400kV line bays – 4 nos. (at C’Peta for termination of LILO of Vijayawada-Nellore 400 kV D/c line at C’Peta)

Estimated Cost : Rs. 5550 Crs

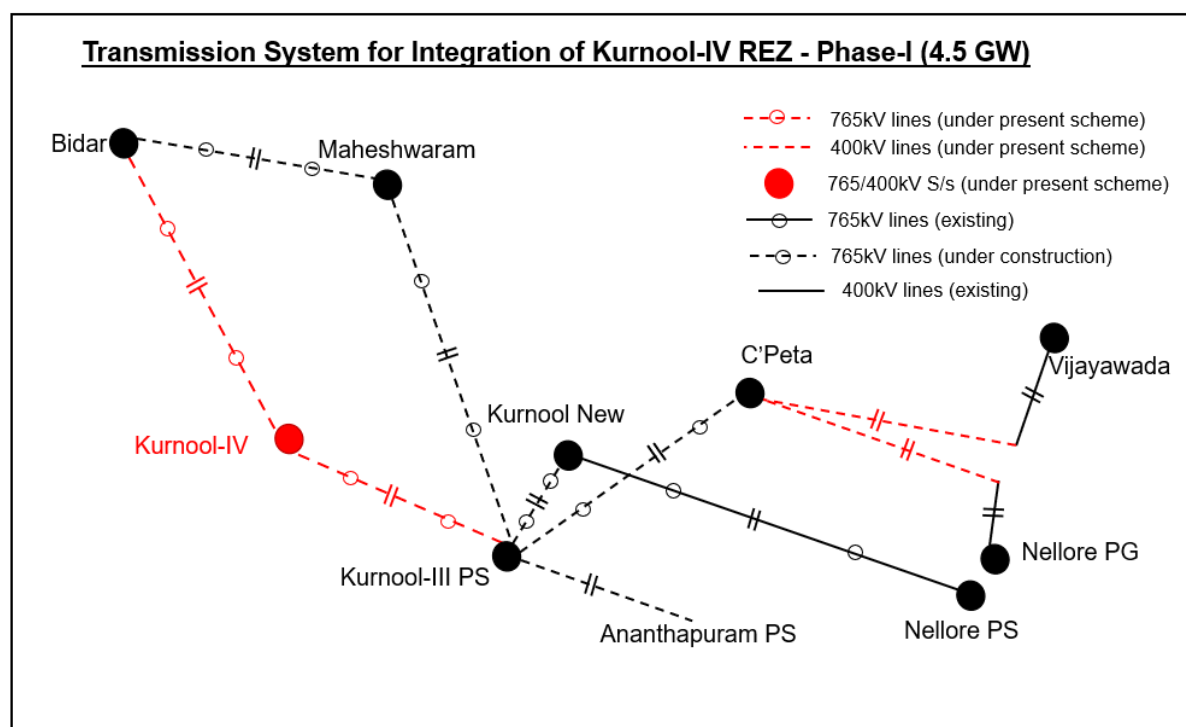

The above transmission scheme has been forwarded to NCT vide CTU letter dated 17.08.2024.

(f) Transmission System for integration of Anantapur-II REZ in Andhra Pradesh

As per the Joint Study meeting of Southern Region Constituents held from 2nd to 4th May, 2024 at Hyderabad, following transmission system was finalized for integration of RE generation projects at Anantapur-I in Andhra Pradesh

Phase-I (4.5 GW)

- Establishment of 4x1500 MVA, 765/400 kV & 4x500 MVA, 400/220 kV Anantapur-II Pooling Station near Kurnool, Andhra Pradesh along with 2x330 MVAR (765 kV) bus reactors at Anantapur-II PS (1.5 GW injection at 220 kV level and 2.5 GW injection at 400 kV level)
- + 300 MVAR STATCOM at Ananthpur-II, 2x125 MVAR MSR
- Anantapur-II – Davangere 765kV D/c line (about 150km) with 240 MVAR SLR at Anantapur-II end on both circuits
- Anantapur-II – Cuddapah 765kV D/c line (about 200km) with 330 MVAR SLR at Anantapur-II end on both circuits

Phase-II (3.5 GW)

- Augmentation of 2x1500 MVA, 765/400 & 6x500 MVA, 400/220 kV Kurnool-IV Pooling Station (2.5 GW injection at 220 kV level and 2 GW injection at 400 kV level)
- Establishment of 3x1500 MVA, 765/400 kV CN'Halli Station along with 2x330 MVAR (765 kV) bus reactors

- Anantapur-II – CN’Halli 765kV D/c line (about 180km) with 330 MVAR SLR at Anantapur-II end on both circuits
- CN’Halli - CN’Halli (KPTCL) 400 kV (quad) D/c line (about 10km)

The above transmission schemes were deliberated in the 32nd CMETS-SR held on 28.06.2024 wherein it was agreed that initially Ananthapuram-II Phase-I may be taken up for implementation and Ananthapuram-II Phase-II may be reviewed as per the observations of the SR constituents.

Further, augmentation of transformation capacity by 2x500 MVA, 400/220kV ICTs (5th & 6th) at Ananthapuram-II PS was discussed and agreed in the 33rd CMETS-SR held on 25.07.2024

The detailed scheme is as below:

Sl. No.	Scope of the Transmission Scheme	Capacity /km
1.	<p>Establishment of 4x1500 MVA, 765/400 & 6x500 MVA, 400/220 kV Ananthapuram-II Pooling Station near Kurnool, Andhra Pradesh along with 2x330 MVA (765 kV) bus reactors at Ananthapuram-II PS with provision of two (2) sections of 4500 MVA each at 400kV level</p> <p>Future Space Provisions:</p> <ul style="list-style-type: none"> • 765/400kV, 1500 MVA, ICTs – 2 nos. • 765kV ICT bays – 2 nos. • 400kV ICT bays – 2 nos. • 400/220kV, 500 MVA, ICTs – 12 nos. • 400kV ICT bays – 12 nos. • 220kV ICT bays – 12 nos. • 765kV line bays – 8 nos. (with provision for SLR) • 400kV line bays – 12 nos. (with provision for SLR) • 220kV line bays – 20 nos. • 220kV Bus Sectionalizer : 2 sets • 220 kV Bus Coupler (BC) Bay – 2 nos. • 220 kV Transfer Bus Coupler (TBC) Bay – 2 nos. • 400kV Bus Sectionalizer : 1 set 	<ul style="list-style-type: none"> • 765/400kV, 1500 MVA, ICTs – 4 nos. (13x500 MVA incl. 1 spare unit) • 765kV ICT bays – 4 nos. • 400kV ICT bays – 4 nos. • 400/220kV, 500 MVA, ICTs – 6 nos. • 400kV ICT bays – 6 nos. • 220kV ICT bays – 6 nos. • 765kV line bays – 4 nos. (at Ananthapuram-II PS for termination of Ananthapuram-II – Davanagere and Ananthapuram-II – Cuddapah 765kV D/c lines) • 765 kV, 330 MVA Bus Reactor – 2 nos. • 765 kV Bus Reactor bays – 2 nos. • 220kV line bays – 6 nos. • 220kV Bus Sectionalizer : 1 set • 220 kV Bus Coupler (BC) Bay – 2 no. • 220 kV Transfer Bus Coupler (TBC) Bay – 2 no.
2.	Ananthapuram-II – Davanagere 765kV D/c line (about 150km) with 240 MVAR SLR (convertible) at Ananthapuram-II end on both circuits	<p>~ 150 km</p> <ul style="list-style-type: none"> • 765 kV line bays – 2 nos. (at Davanagere PS) • 765 kV, 240 MVA SLR at Ananthapuram-II PS – 2 nos. (7x80 MVA inc. 1 switchable spare unit)
3.	Ananthapuram-II – Cuddapah 765kV D/c line (about 200km) with 330 MVAR SLR	~ 200 km

Sl. No.	Scope of the Transmission Scheme	Capacity /km
	(convertible) at Ananthapuram-II end on both circuits	<ul style="list-style-type: none"> • 765 kV line terminal equipments – 2 nos. (at Cuddapah) • 765 kV, 330 MVAR SLR at Ananthapuram-II PS – 2 nos. (7x110 MVAR inc. 1 switchable spare unit for both bus reactor and line reactor)
4.	± 300 MVAR STATCOM at Ananthapuram-II PS along with 2x125 MVAR MSR	• 400 kV bay – 1 no.

Estimated Cost : Rs. 4679 Crs

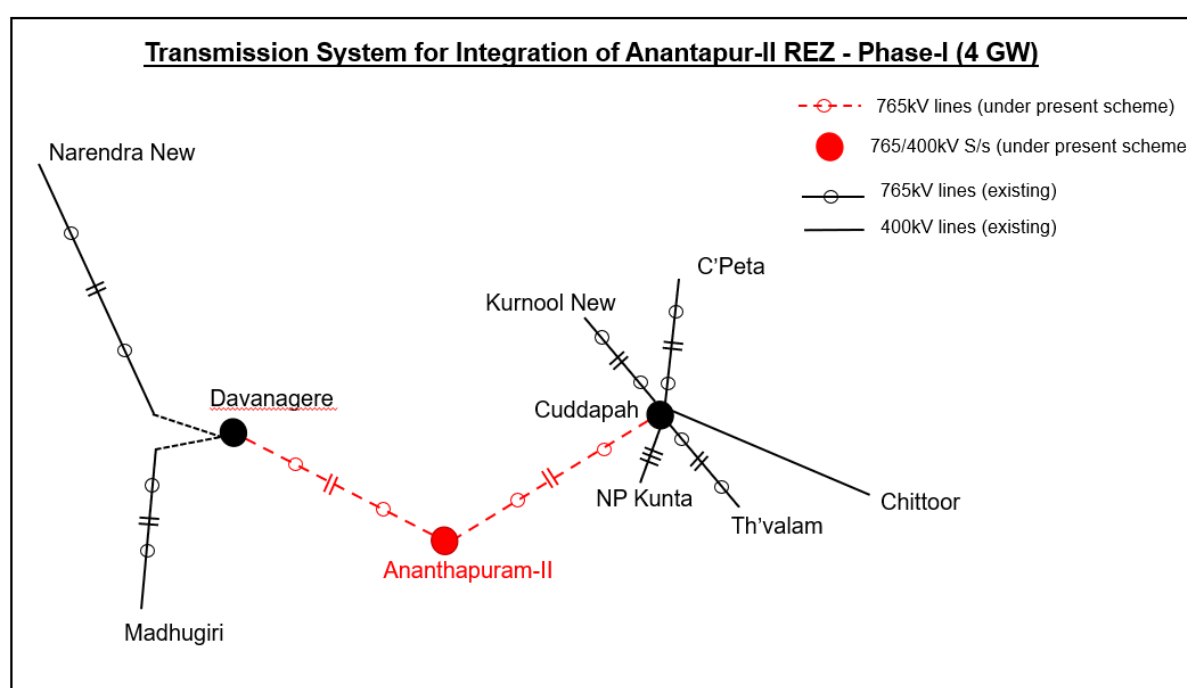

The above transmission scheme has been forwarded to NCT vide CTU letter dated 17.08.2024.

(g) Transmission System for proposed Green Hydrogen / Green Ammonia projects in Kakinada area, Andhra Pradesh

Govt. of India has set a CTU informed that a meeting was held on 19.10.2023 chaired by Hon'ble Minister with Green Hydrogen stakeholders/association, wherein it was instructed that developers shall share the details of year-wise planned Green Ammonia / Green Methanol capacities and corresponding drawl capacities desired at different locations. Hon'ble minister also instructed that this information should be shared with CTU for planning the required substation capacities at these specified locations. MNRE vide letter dated 01.11.2023 has forwarded the consolidated information of the planned projects and drawl requirements of various developers.

Subsequently, CEA convened a meeting with Green Hydrogen/ Green Ammonia manufacturers to access the year wise electricity demand for proper planning of

transmission system. In Kakinada area, about 6000 MW demand has been envisaged for the Green Hydrogen/ Green Ammonia projects. The details of the phased development are as follows

Year	Cumulative Electricity Demand (MW)
by 2027	1775
by 2028	3275
by 2029	4645
by 2030	6015

CTU has already received application from M/s AM Green Ammonia (India) Pvt. Ltd. seeking GNA-RE for 700 MW as Bulk Consumer in Kakinada area. The application is under discussion for grant of GNA in CMETS meeting. Further AM Green Ammonia (India) Private Limited vide email dated 20.01.2024 has indicated that they are in the process of developing a 2 MPTA Green Ammonia Project in Kakinada, Andhra Pradesh in phased manner. The total drawl requirement for the entire Green Ammonia Kakinada project capacity is 3370 MW. The details of the phased development are as follows

Year	Electricity Demand (MW)
Phase I	700
Phase II	700
Phase III	1300
Phase IV	660

Further, application has also been received from M/s AM Green Ammonia (India) Pvt. Ltd. for additional 1300 MW in the month of July 2024, seeking GNA-RE for additional 1300 MW as Bulk Consumer for Green Hydrogen loads in Kakinada area.

In view of the upcoming Green Hydrogen / Green Ammonia plants / industries, planning of transmission system has been done for delivery of power to Green Hydrogen / Ammonia manufacturing projects at Kakinada in Andhra Pradesh. Upon discussions between CTU and CEA, following transmission system identified for supply of power to Green Hydrogen / Ammonia projects at Kakinada was deliberated in the 33rd CMETS-SR held on 25.07.2024

Transmission system for proposed Green Hydrogen / Green Ammonia projects in Kakinada area

Phase-I : 3000 MW

- Establishment of Kakinada 765/400 kV, 3x1500 MVA substation
- LILO of Vemagiri – Srikakulam 765 kV D/c line at Kakinada substation

*Note * : Angul – Srikakulam 765 kV 2nd D/c line shall be required which is to be taken up for enhancement of TTC/ATC*

Phase-II : Cumulative 6000 MW

- Augmentation by 3x1500 MVA, 765/400 kV ICTs at Kakinada substation
- Establishment of Khammam-II 765/400 kV, 3x1500 MVA substation

- Warangal – Khammam-II 765 kV D/c line
- Khammam-II – Vemagiri 765 kV D/c line
- Khammam-II – Khammam (existing) 400 kV D/c (quad) line
- Vemagiri – Kakinada 765 kV 2nd D/c line

During the meeting, CTU informed that the proposed Phase-I Transmission system for Green Hydrogen / Green Ammonia projects in Kakinada area shall be required for immediate integration and supply of power to these projects irrespective of other transmission system strengthening including HVDC system. Further, CTU has already received applications from Green Hydrogen / Green Ammonia projects for 2000 MW which is to be disposed of in time bound manner in accordance with the CERC GNA Regulations, 2022. Accordingly, Transmission system for proposed Green Hydrogen / Green Ammonia projects in Kakinada area, Andhra Pradesh (Phase-I) may be put up for formal approval and the balance Phase-II transmission system and HVDC proposal may be submitted to SRPC for further deliberations alongwith the inter-regional links studied during the Joint Study meeting.

After detailed deliberations, the proposal for “Transmission system for proposed Green Hydrogen / Green Ammonia projects in Kakinada area, Andhra Pradesh (Phase-I)” was discussed and agreed in the 33rd CMETS-SR held on 25.07.2024, the details of the transmission scheme are as below:

Transmission system for proposed Green Hydrogen / Green Ammonia projects in Kakinada area (Phase-I)

- Establishment of Kakinada 765/400 kV, 3x1500 MVA substation alongwith bus reactor
- LILO of Vemagiri – Srikakulam 765 kV D/c line at Kakinada substation

Note * : Angul – Srikakulam 765 kV 2nd D/c line shall be required which is to be taken up for enhancement of TTC / ATC

Estimated Cost : Rs. 1015 Crs

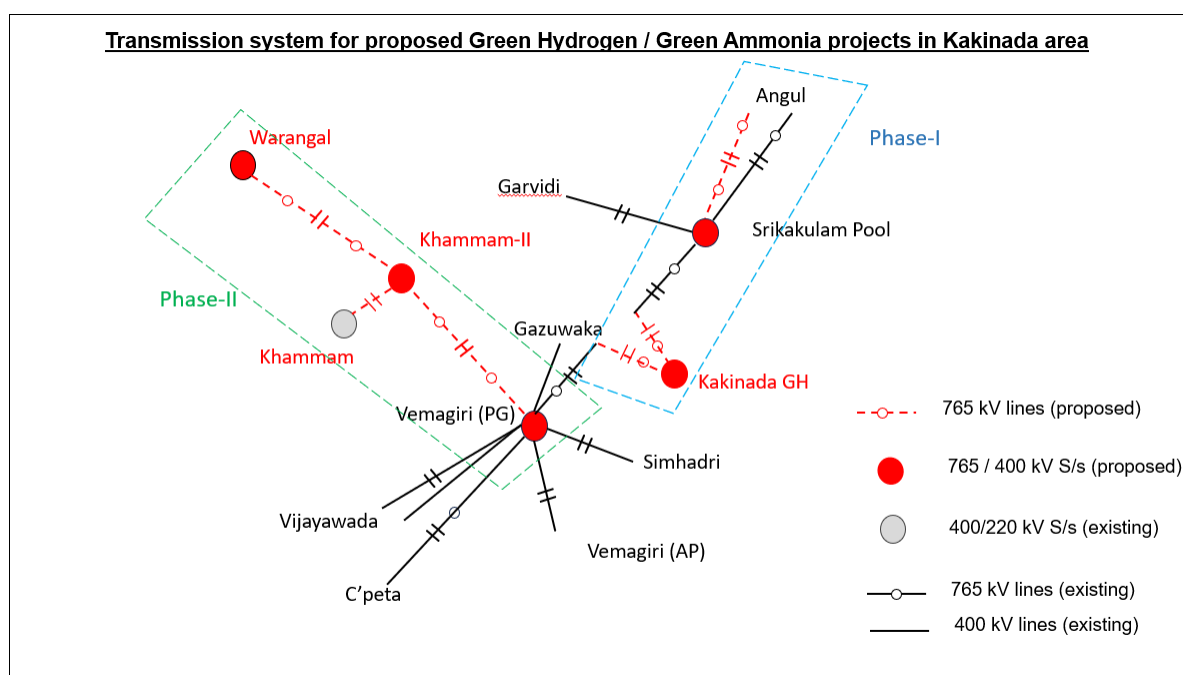

6.4.3 Tamil Nadu

(a) Transmission System for 1 GW Offshore wind farm (Phase-I) in Tamil Nadu

Govt. of India has set a target of 500 GW capacity addition from non-fossil fuel based generation capacity by 2030. MNRE has identified about 30 GW Offshore wind potential each in the coast of Gujarat and Tamil Nadu. A report on Transmission System for Integration of over 500 GW RE Capacity has been published by CEA on 07.12.2022 wherein initially 5 GW Offshore wind potential each at Gujarat (CUF – 37%) and Tamil Nadu (CUF – 48%) has been prioritized for implementation by 2030.

Further, a meeting on “Offshore development” was held under chairmanship of Shri R.K. Singh, Hon’ble Minister of Power and New & Renewable Energy on 14.06.2023, to discuss the issues related to grid connection, timelines and bidding of offshore wind energy projects under various models. During the meeting, it was decided that initially 2GW offshore evacuation infrastructure (1 GW in Gujarat and 1 GW in Tamil Nadu) may be developed by PGCIL under RTM and further 4GW evacuation infrastructure will be developed under TBCB. Same was also decided in the meeting held on 16.08.2023 between MNRE & CTUIL. Further, in the meeting held on 22.12.2023 in MNRE for finalization of the specifications of the transmission infrastructure, it was decided that 500 MW VGF project off-Tamil Nadu coast to be commissioned by March 2029 for which tender shall be published by March 2025. Further, 4 GW non-VGF project off-Tamil Nadu coast to be commissioned by in FY 029-30 for which tender are to be published on 01.02.2024.

The transmission system for the 1 GW Offshore wind generation in Tamil Nadu was deliberated during the 28th CMETS meeting held on 29.02.2024 and was forwarded to SRPC for views on 05.03.2024 and same was deliberated in the 50th SRPC meeting held

on 16.03.2024. SRPC vide letter dated 18.04.2024 has forwarded the views of Southern Region constituents.

The transmission system was discussed in the 20th NCT meeting held on 25.06.2024. During the 20th NCT meeting, based on the inputs from MNRE, it was decided that initially transmission system for 500 MW VGF offshore wind generation project may be taken up for implementation. The details of the transmission system is as below:

A. Transmission System onwards Onshore Pooling Station

- Establishment of 2x500 MVA, 400/230 kV Onshore Pooling Station near Avaraikulam, Tirunelveli District in Tamil Nadu with provision of expansion upto 5 GW.
- Avaraikulam Onshore PS – Tuticorin PS 400 kV D/c quad line (approx. 100 km)
- + 300 MVAr STATCOM along with 2x125 MVAr MSR

Estimated Cost : Rs. 1096 Crs

B. Transmission System for integration of Offshore Wind Farms with Onshore PS

Offshore Substation-1 {500 MW VGF} :

- Establishment of 2x315 MVA, 230/66kV Off-Shore Substation-1 with 10 nos. of 66kV line bays for RE integration
- Offshore substation 1 (OSS-1) – Avaraikulam Onshore PS 2 nos. 230kV (atleast 300 MVA capacity) Submarine cables (~35 - 40 km) with 2x50MVAr switchable line reactors at OSS-1 end

Estimated Cost : Rs. 5146 Crs

Total Estimated Cost : Rs. 6242 Crs



(b) Implementation of 1 nos. of 230kV line bay at Karur 400/230kV PS for integration of RE generation project (M/s Nannai Solar Park Private Ltd.)

Presently, Karur 400/230kV PS is under operation with 2x500 MVA, 400/230kV ICTs and 2x500 MVA, 400/230kV ICTs (3rd & 4th) are under implementation and expected commissioning schedule is 11.09.2025. During the 30th CMETS-SR held on 30.04.2024, Connectivity of 93 MW has been agreed for grant to M/s Nannai Solar Park Private Ltd. at 230kV level with 1 nos. of 230kV line bay. The applicant has requested for implementation of 230kV bay at Karur PS under ISTS and same was agreed. The details are as below:

Sl. No.	Description of Transmission Element	Scope of work	Schedule
1	1 no. 230kV line bay at Karur 400/230kV PS for termination of dedicated line of M/s Nannai Solar Park Private Ltd.	230kV line bays – 1 Nos.	30.09.25

Estimated cost : Rs. 6 Crore

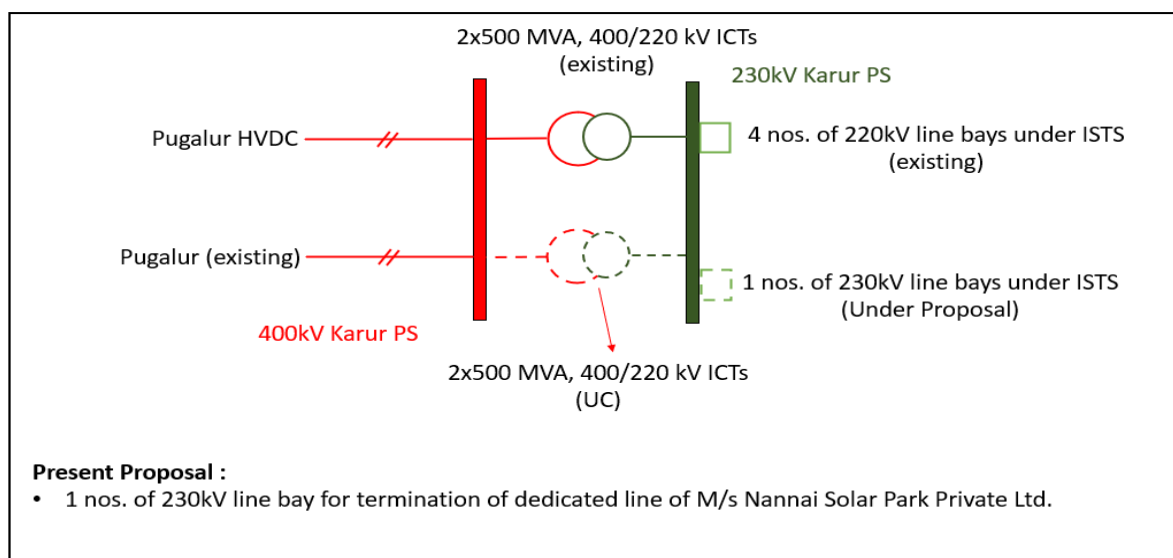

(c) Transmission system for proposed Green Hydrogen / Green Ammonia projects in Tuticorin area.

A meeting was held on 19.10.2023 chaired by Hon'ble Minister of Power and NRE with Green Hydrogen stakeholders/association, wherein it was decided that developers shall share the details of year-wise planned Green Ammonia / Green Methanol capacities and corresponding drawl capacities desired at different locations. It was also decided that this information should be shared with CTU for planning the required substation capacities at these specified locations. MNRE vide letter dated 01.11.2023 has forwarded the consolidated information of the planned projects and drawl requirements of various developers.

Subsequently, CEA convened a meeting with Green Hydrogen / Green Ammonia manufacturers to access the year wise electricity demand for proper planning of transmission system. In Tuticorin area, about 7000 MW demand has been envisaged for the Green Hydrogen / Green Ammonia projects. The details of the phased development are as follows:

Year	Cumulative Demand (MW)	Electricity
By 2027	2900	
By 2028	2900	
By 2029	5645	
By 2030	7015	

In view of the upcoming Green Hydrogen / Green Ammonia projects, transmission system has been identified for delivery of power to the potential Green Hydrogen / Green Ammonia projects. After discussion, CEA & CTU identified following transmission system for supply of power at Tuticorin to potential Green Hydrogen / Green Ammonia projects :

Proposed Transmission network:

- Establishment of Tuticorin (GH) 765/400 kV, 3x1500 MVA S/s with 1x240 MVAR Bus Reactor.
- Tuticorin Pool – Tuticorin (GH) 765 kV D/c line.
- Upgradation of 765 kV Tuticorin Pool (presently charged at 400 kV) to its rated voltage at 765 kV.
- Upgradation of 765 kV Dharmapuri (presently charged at 400 kV) to its rated voltage at 765 kV.
- Upgradation of Tuticorin Pool – Dharmapuri 765 kV line (presently charged at 400 kV) to its rated voltage at 765 kV.
- Upgradation of Dharmapuri – Madhugiri 765 kV line (presently charged at 400 kV) to its rated voltage at 765 kV

In the meanwhile, application under GNA Regulations has been received from M/s AM Green Ammonia (India) Pvt. Ltd. in Feb, 2024 seeking grant of GNA-RE as Bulk Consumer for 1660 MW as per below details :

Name of the Applicant	GNA (Within & outside region)	Nature of Applicant	Location details of GNA (requested)	Start date of GNA (requested)	End date of GNA (requested)
AM Green Ammonia (India) Pvt. Ltd.	Within Region: 0 MW Outside Region: 1660MW	Bulk consumer seeking to connect to ISTS	Tuticorin PS	01.12.2026	30.11.2051

M/s AM Green Ammonia (India) Pvt. Ltd. has indicated that they are in the process of developing Green Ammonia Plant in phased manner. The total drawl requirement for the entire Green Ammonia Tuticorin project capacity shall be 2260 MW. The application was discussed in the 31st CMETS-SR, held on 30.05.2024 wherein it was decided that GNA-RE may be granted to M/s AM Green Ammonia (India) Pvt. Ltd. at Tuticorin for production of Green Hydrogen / Green Ammonia through following transmission scheme:

- Establishment of 3x1500 MVA, 765/400 kV Tuticorin (GH) project with 1x240 MVAR bus Reactor.
- Tuticorin Pool – Tuticorin (GH) 765 kV D/c line.
- Upgradation of 765 kV Tuticorin Pool (presently charged at 400 kV) to its rated voltage at 765 kV along with 3x1500 MVA, 765/400 kV ICTs and 1x330 MVAR bus Reactor.
- Upgradation of 765 kV Dharmapuri (presently charged at 400 kV) to its rated voltage at 765 kV along with 3x1500 MVA, 765/400 kV ICTs and 1x330 MVAR bus Reactor.
- Upgradation of Tuticorin Pool – Dharmapuri 765 kV line (presently charged at 400 kV) to its rated voltage at 765 kV alongwith 1x330 MVAR Switchable Line Reactor at both end of each circuit.
- Upgradation of Dharmapuri – Madhugiri 765 kV line (presently charged at 400 kV) to its rated voltage at 765 kV alongwith 1x330 MVAR Switchable Line Reactor at Dharmapuri end of each circuit

The above transmission schemes have been forwarded to SRPC for views vide letter dated 10.07.2024. The transmission scheme was discussed and agreed in principally in the 52nd SRPC meeting held on 03.08.2024.

Sl. No.	Scope of the Transmission Scheme	Capacity /km
1.	Establishment of 3x1500 MVA, 765/400 kV Tuticorin (GH) S/s with 1x240 MVAR bus Reactor Future Space Provisions: <ul style="list-style-type: none"> • 765/400kV, 1500 MVA, ICTs – 3 nos. • 765kV ICT bays – 3 nos. • 400kV ICT bays – 3 nos. • 765kV line bays – 6 nos. (with provision for SLR) • 400kV line bays – 16 nos. (with provision for SLR) • 400kV Bus Sectionalizer : 1 set 	<ul style="list-style-type: none"> • 765/400kV, 1500 MVA, ICTs – 3 nos. (10x500 MVA incl. 1 spare unit) • 765kV ICT bays – 3 nos. • 400kV ICT bays – 3 nos. • 765kV line bays – 2 nos. (at Tuticorin (GH) S/s for termination of Tuticorin (GH) – Tuticorin PS 765kV D/c line) • 765 kV, 240 MVAR Bus Reactor – 1 nos. (4x80 MVAR inc. 1 switchable spare unit) • 765 kV Bus Reactor bays – 1 nos.
2.	Tuticorin PS – Tuticorin (GH) 765 kV D/c line	~ 50 km <ul style="list-style-type: none"> • 765kV line bays – 2 nos. (at Tuticorin PS)
3.	Upgradation of Tuticorin PS - Dharmapuri (Salem New) 765kV D/c line (presently charged at 400kV level) at its rated 765kV voltage level with 1x330 MVAR switchable Line Reactor on both ends of each circuit	<ul style="list-style-type: none"> • 765kV line bays Tuticorin PS – 2 nos. • 765 kV, 330 MVAR SLR at Tuticorin PS – 2 nos. (7x110 MVAR inc. 1 spare unit for both bus reactor and line reactor) • 765kV line bays at Dharmapuri (Salem New) – 2 nos. • 765 kV, 330 MVAR SLR at Dharmapuri (Salem New) – 2 nos. (7x110 MVAR inc. 1 spare unit for both bus reactor and line reactor)
4.	Transmission line for change of termination from 400kV switchyard to 765kV switchyard for Tuticorin PS – Dharmapuri (Salem New) 765kV D/c line at Tuticorin PS & Dharmapuri (Salem New)	Approx. 1-2 kms at each end
5.	Upgradation of Tuticorin PS to its rated voltage of 765kV level alongwith 3x1500 MVA, 765/400kV ICTs and 1x330 MVAR, 765kV bus reactors Future Space Provisions: <ul style="list-style-type: none"> • 765/400kV, 1500 MVA, ICTs – 1 no. • 765kV ICT bays – 1 no. • 400kV ICT bays – 1 no. • 765kV line bays – 6 nos. (with provision for SLR) 	<ul style="list-style-type: none"> • 765/400kV, 1500 MVA, ICTs – 3 nos. (10x500 MVA incl. 1 spare unit) • 765kV ICT bays – 3 nos. • 400kV ICT bays – 3 nos. • 765 kV, 330 MVAR Bus Reactor – 1 nos. • 765 kV Bus Reactor bays – 1 nos.
6.	Upgradation of Dharmapuri (Salem New) to its rated voltage of 765kV level alongwith 3x1500 MVA, 765/400kV ICTs and 1x330 MVAR, 765kV bus reactor	<ul style="list-style-type: none"> • 765/400kV, 1500 MVA, ICTs – 3 nos. (10x500 MVA incl. 1 spare unit) • 765kV ICT bays – 3 nos. • 400kV ICT bays – 3 nos.

Sl. No.	Scope of the Transmission Scheme	Capacity /km
	Future Space Provisions: <ul style="list-style-type: none"> • 765/400kV, 1500 MVA, ICTs – 1 no. • 765kV ICT bays – 1 no. • 400kV ICT bays – 1 no. • 765kV line bays – 6 nos. (with provision for SLR) 	<ul style="list-style-type: none"> • 765 kV, 330 MVA Bus Reactor – 1 nos. • 765 kV Bus Reactor bays – 1 nos.
7.	400 kV line reactors on Tuticorin PS - Dharmapuri (Salem New) 765kV D/c line shall be utilized as bus reactors at respective 400kV substations based on availability of bays.	
8.	Upgradation of Dharmapuri (Salem New) – Madhugiri 765kV 2xS/c lines (presently charged at 400 kV) to its rated voltage at 765 kV with 1x330 MVA switchable Line Reactor on Dharmapuri (Salem New) end of each circuit	<ul style="list-style-type: none"> • 765kV line bays at Dharmapuri (Salem New) – 2 nos. • 765 kV, 330 MVA SLR at Dharmapuri (Salem New) – 2 nos. (6x110 MVA switchable units) • 765kV line bays at Madhugiri – 2 nos.
9.	Transmission line for change of termination from 400kV switchyard to 765kV switchyard for Dharmapuri (Salem New) – Madhugiri 765kV 2xS/c line at Dharmapuri (Salem New) & Madhugiri	Approx. 1-2 kms at each end
10.	400 kV line reactors on Dharmapuri (Salem New) – Madhugiri 765 kV 2xS/c lines shall be utilized as bus reactors at respective 400kV substations based on availability of bays.	

Estimated cost : Rs. 2617 Crore

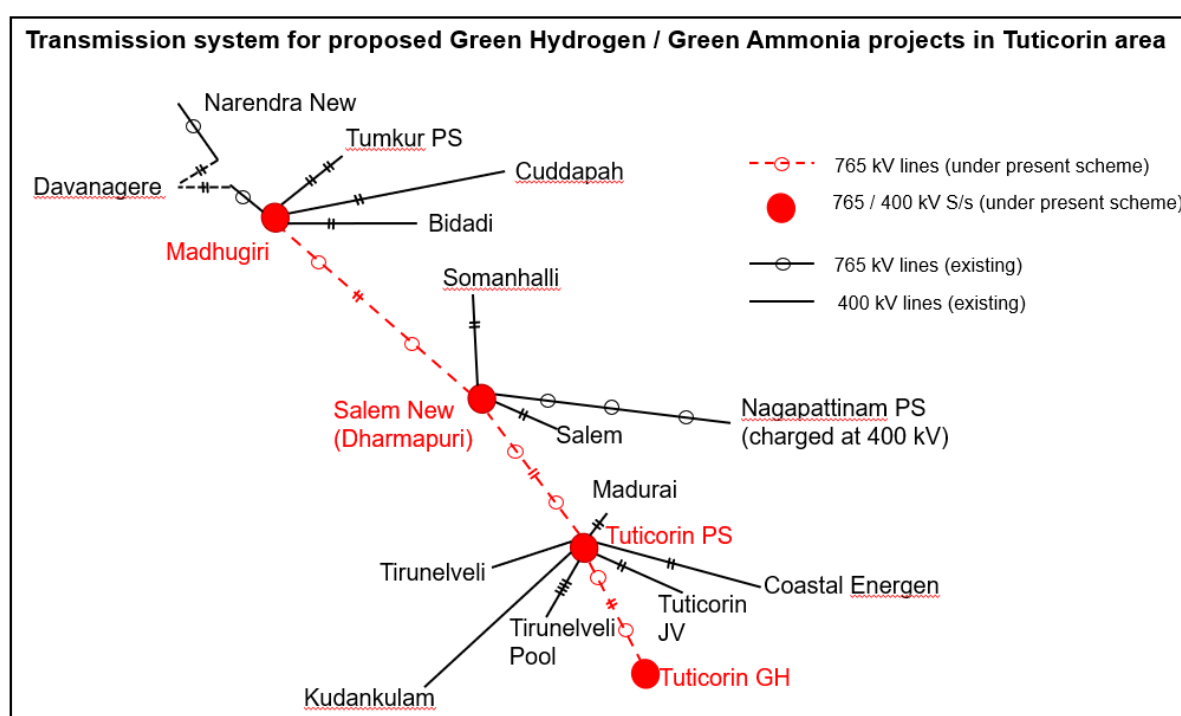

Chapter 7: Eastern Region

Eastern Region is stretching from Sikkim in the southern Himalayas to the coast of the Bay of Bengal. In this region, the states of Bihar and West Bengal lie on the Indo - Gangetic plain and Jharkhand lies on the Chota-Nagpur Plateau. Odisha lies on the Eastern Ghats and the Deccan Plateau. The region is bounded by Bhutan & Nepal in the north, the states of Uttar Pradesh & Chhattisgarh on the west, the state of Andhra Pradesh in the south and the state of Assam and country of Bangladesh in the east. It has a very important narrow corridor between international border of Nepal and Bangladesh, called “Chicken's Neck”, with a size of 18km by 22km, which connects the north Bengal, Sikkim and entire North Eastern Region with the remaining part of National Grid. The ER has immense potential for natural resources comprising of large thermal and nuclear reserves in the country.

The generating stations of Eastern Regions are predominantly concentrated in the coal rich states of Jharkhand, Odisha and West Bengal and hydro generations are concentrated in Sikkim and southern part of Odisha. Cross-border interconnection in the Eastern Region facilitates in optimal utilization of energy resources in South Asian region in a cost effective manner. During wet season (Monsoon period) hydro power is imported from Bhutan and Nepal and during dry season (Winter period), surplus power is exported to these countries to meet their energy requirement. Cross-border interconnection with Bangladesh in Eastern region helps Bangladesh in meeting its energy requirement throughout the year.

7.1 Power Supply Scenario as on Aug'24

As on Aug'2024, total Installed Capacity (IC) of Eastern Region was about 35.9 GW and the peak demand met was about 31.4 GW. The state-wise breakup of installed capacity and peak demand is summarised at Table 7-1 below.

Table 7-1 ER Installed Capacity and Peak Demand as on Aug'24

(All Fig in MW)

Region	Fossil			Non Fossil				Grand Total	Peak Demand Met
	Thermal	Gas	Total	Nuclear	Hydro	RES* (MNRE)	Total		
Bihar	7433	0	7433	0	110	450	560	7993	7,888
Jharkhand	2607	0	2607	0	191	195	386	2993	3,548
DVC	3037	0	3037	0	186	0	186	3223	2,292
Odisha	5291	0	5291	0	2163	691	2855	8146	6,905
West Bengal	8683	80	8763	0	1396	645	2041	10804	12,640
Sikkim	104	0	104	0	633	63	696	799	111
Central unallocated	1836	0	1836	0	85	0	85	1921	64
Total	28992	80	29072	0	4764	2044	6808	35880	31,399

Source: CEA monthly report

7.2 Envisaged Power Supply Scenario by 2029-30

As per the 20th EPS, Eastern Region demand for 2029-30 timeframe is expected to increase to about 45.7 GW. As per the inputs received from various stakeholders, total installed capacity of Eastern Region for 2029-30 is expected to be about 69.5 GW. The state wise bifurcation of installed capacity and peak demand is summarized below at Table 7-2.

Table 7-2: ER Installed Capacity and Peak Demand (2029-30)

(All Fig in MW)

State	Generation								Peak Demand	
	Fossil			Non Fossil				ESS / PSS/ Rooftop		Grand Total
	Thermal	Gas	Total	Nuclear	Hydro	RES	Total			
Bihar	2040	0	2040	0	45	700	745	0	2785	13360
Jharkhand	2820	0	2820	0	130	1415	1545	0	4365	4597
DVC	0	0	0	0	0	0	0	0	0	5176
Odisha	2490	0	2490	0	2193	403	2596	600	5686	9107
West Bengal	8000	0	8000	0	574	0	574	900	9474	15507
Sikkim	0	0	0	0	14	0	14	0	14	214
Central	31570	0	31570	0	5819	0	5819	0	37389	-
IPP	4500	0	4500	0	5252	0	5252	0	9752	-
ER	51420	0	51420	0	14026	2518	16544	1500	69464	45752

There is a growth in peak demand of Eastern Region from present time-frame (Aug 2024) to 2029-30 with a CAGR of 7.8%. The state wise peak demand growth is given at Table 7-3.

Table 7-3: Increase in Peak Demand of Various States of ER

(All Fig in MW)

State	Aug 2024	2029-30	Increase in demand	CAGR
Bihar	7888	13360	5472	11.1%
DVC	2292	5176	2884	17.7%
Jharkhand	3548	4597	1049	5.3%
Odisha	6905	9107	2202	5.7%
Sikkim	111	214	103	14.0%
West Bengal	12640	15507	2867	4.2%
Andaman	57	72	15	4.8%
ER	31399	45752	14353	7.8%

From the above data it is observed that the CAGR growth of peak demand is maximum for DVC (17.7%) and minimum for West Bengal (4.2%). The CAGR of demand of ER is about 7.7% which is more than the National Average of 6%.

In addition to above, bulk power demand of about 9500MW proposed to be directly connected to ISTS/intra state has also been considered from various upcoming green hydrogen/ green ammonia identified by MNRE, bulk consumers/distribution licensees. Major demand corresponding to the above loads in ER includes Paradeep (ISTS): 3000MW, Gopalpur (ISTS): 3000MW, Duburi-765 (OPTCL): 1500MW, Khuntuni (OPTCL):1500MW & various other bulk consumers/distribution licensees/intra state embedded drawee entities who have been granted GNA under GNA Regulations, 2022.

The hydro generations of Bhutan (about 4500MW) and Nepal (3300MW) and demand of Bangladesh (1000MW) have been considered in 2029-30 timeframe as a part of Eastern Region for the purpose of study.

7.3 Load Generation Balance for 2029-30 timeframe

In the chapter 3, All India Load Generation Balance (LGB) for identified nine scenarios was prepared as per the methodology finalized in a meeting among CTU, CEA and Grid-India. This section elaborates the Eastern Region Load Generation Balance (LGB) for 2029-30 timeframe. For Eastern Region also, three points on the daily load curve i.e. Solar max (afternoon), Peak load (evening) and Off-peak load (night) for three seasons viz. Monsoon (August), Summer (June) and Winter (February) have been considered.

Load generation balance has been prepared considering the generation despatch factors as mentioned at Table 7-4 for the 9 scenarios. Further, thermal generators have been despatched as per the merit order.

Table 7-4: Eastern Region Generation Dispatch and Demand Factors

Scenario No & Name	Generation Dispatch Factors			Demand Factors
	Hydro	Solar	Pump storage	
1-Aug Solar Max	70%	80%	-100%	90%
2-Aug Peak Load	90%	0%	60%	96%
3-Aug Night Off Peak	70%	0%	40%	81%
4-Jun Solar Max	70%	85%	-100%	94%
5-Jun Peak Load	90%	0%	50%	89%
6-Jun Night Off Peak	70%	0%	0%	69%
7-Feb Solar Max	30%	90%	-100%	68%
8-Feb Peak Load	60%	0%	100%	73%
9-Feb Night Off Peak	30%	0%	40%	59%

7.4 ISTS Network Expansion Schemes Evolved from Feb'24/Mar'24 to July'24

Various transmission schemes have been discussed/finalized in the Consultative Meeting for Evolution of Transmission System of Eastern Region (CMETS-ER) from Feb'24/Mar'24 to July'24. The brief of all such transmission schemes is tabulated below in Table 7-5:

Table 7-5: Approved Transmission Schemes in this Rolling Plan

Sl. No.	Name of the Transmission Scheme	Scheme Type (RE/Conventional/Drawal incl strengthening)	Expected Timeframe	Tentative Cost (in ₹Cr.)	Quantum (MW)
West Bengal					
1.	Eastern Region Generation Scheme-II (ERGS-II) – DTPS Evacuation	Conventional	1 st Aug 2028	455.37	400
Odisha					
1.	Eastern Region Expansion Scheme-42 (ERES-42) – 3 rd ICT at Pandiabili	Strengthening	30 th Sep 2026	45.58	-
Bihar, Odisha & West Bengal					
1.	Eastern Region Expansion Scheme-43 (ERES-43) – Reconductoring (Farakka-Kahalgaoon & Talcher - Meramunduli)	Strengthening	3 rd April 2026	310.28	-
Total				~812	

7.4.1 Odisha

(i) ERES-42 – 3rd ICT at Pandiabili

Presently, 400/220kV Pandiabili (POWERGRID) S/s is having the transformation capacity of 2x500MVA. The maximum loading has crossed 500MW. Further, with upcoming Pratapsan – Cuttack 220kV line and Pandiabili (POWERGRID) – Samangara 220kV line, the existing transformers would breach the N-1 criteria. Accordingly, there is requirement of new 1x500MVA, 400/220kV (3rd) ICT at Pandiabili (POWERGRID) S/s.

At present, 1 no. 400kV spare GIS bay is being implemented at Pandiabili GIS S/s (under approved ERBS-I scheme) with completion schedule of 30-09-2024. The said spare bay is planned to be used for installation of 3rd ICT. The same timeline viz. 30-09-2024 is planned for augmentation of transformation capacity at Pandiabili S/s so as to match availability of ICT and associate bay. For installation of 3rd ICT, there is requirement of GIB duct of 250m (1-Ph) and 100m (1-Ph) at 400kV and 220kV levels respectively.

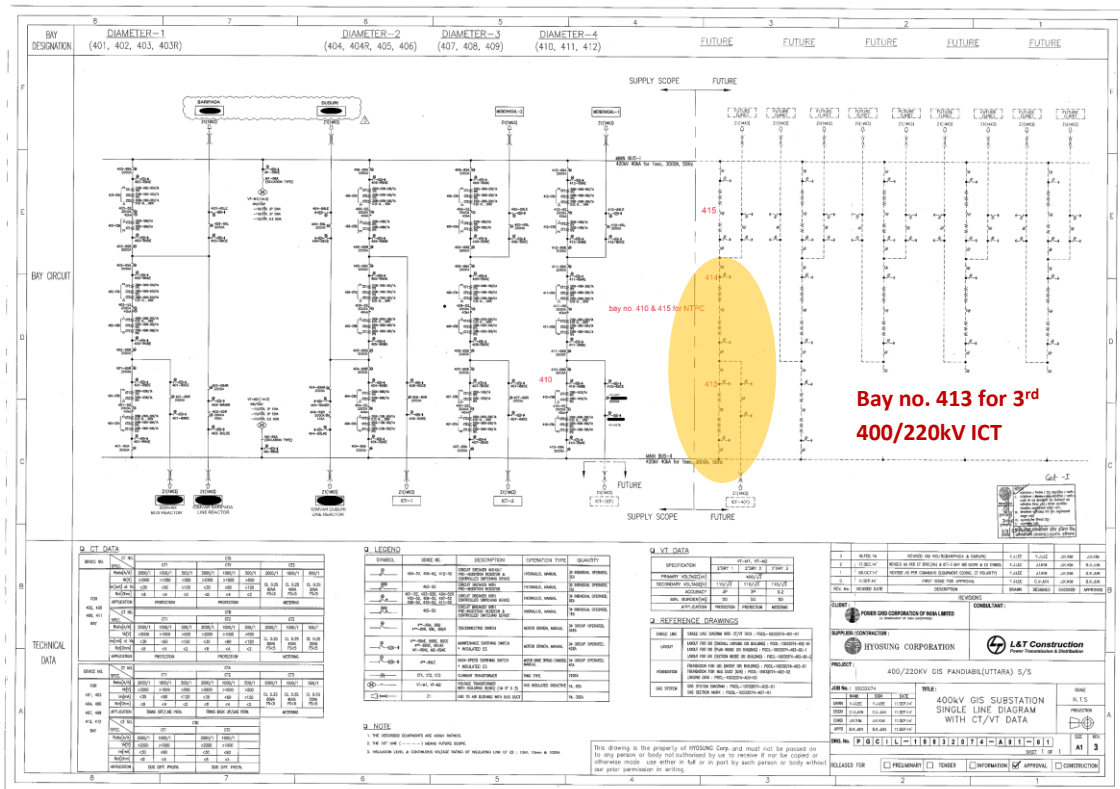

Figure 7-1 SLD of Pandiabli for ERES-42

This scheme has been agreed in the 31st CMETS-ER held on 30-05-2024. Schematic is given at Figure 7-1. **Error! Reference source not found.**

Sl. No.	Scope of the Transmission Scheme	Capacity (MVA) / Line length (km)/ Nos.
1.	Installation of new 1x500MVA, 400/220kV (3rd) ICT at Pandiabli (POWERGRID) S/s along with associated bay at 220kV level [using the bay no. 413 at 400kV level, which is already under implementation under ERBS-I scheme].	<ul style="list-style-type: none"> 500MVA, 400/220kV ICT: 1 no. 220kV GIS ICT bay: 1 no. 400kV GIS duct: 250m approx.(1-Ph) 220kV GIS duct: 100m approx.(1-Ph)
<p>Note: POWERGRID is inter alia implementing a full diameter (413-414-415) under ERBS-I scheme for termination of one circuit of Talcher-III – Pandiabli (POWERGRID) 400kV D/c line in bay no. 415. The other bay of the diameter viz. 413 is planned to be used for termination of the 3rd 400/220kV ICT.</p>		

Implementation time-frame: 30-09-2026

7.4.2 West Bengal

(i) ERGS-II – DTPS Evacuation

Damodar Valley Corporation (DVC) had applied ISTS connectivity for 400MW and intra-state connectivity for 400MW for its upcoming Durgapur Thermal Power Station of 800MW (1x800MW) at Paschim Bardhwan, West Bengal. Alternatives for providing

Connectivity to this generation project at nearby ISTS substations were explored. System studies were carried out for 2028-29 timeframe and discussed in the joint study meeting among CEA, ERPC, CTU, ERLDC, DVC and West Bengal on 23-07-2024. Considering generation project of DVC and increasing load demand in West Bengal, a new switching station was proposed at Bishnupur area (with a provision for upgradation with 400/220kV ICTs at a later stage). Based on the outcomes of the joint study meeting held on 23-07-2024 and as decided in the 33rd Consultation Meeting for Evolving Transmission Schemes in Eastern Region (CMETS-ER) held on 29-07-2024, ISTS Connectivity of 400MW was provided to DVC for its Durgapur Thermal Power Station at Bishnupur (ISTS) 400kV switching station which would be further connected to existing 765/400kV Medinipur (POWERGRID) substation through a 400kV D/c (Quad) line. As the new ISTS has been identified entirely for evacuation of power from DVC's DTPS generation, it was agreed that the new substation and associated lines for connection to existing Medinipur (POWERGRID) substation shall be implemented in ISTS as ATS under the Eastern Region Generation Scheme-II (ERGS-II) with completion time schedule as 01-08-2028 matching with the start date of connectivity.

The scheme has been agreed in the 33rd CMETS-ER held on 29th July 2024. Schematic is given at **Figure 7-2**.

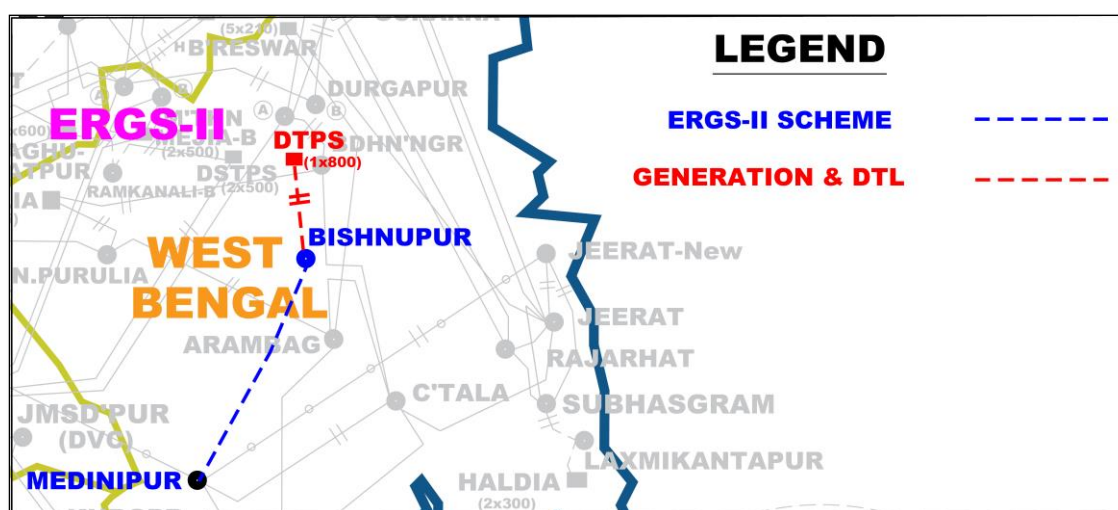

Figure 7-2: Schematic ERGS-II

Sl. No.	Scope of the Transmission Scheme	Capacity/ km
1	Establishment of new 400kV switching station at Bishnupur (Dist. Bankura) in West Bengal with provision to establish 400/220kV level in future	-
2	Bishnupur (ISTS) – Medinipur (ISTS) 400kV (Quad Moose) D/c line	70km
3	Extension at Medinipur (ISTS) S/s: 2 no. 400kV line bays for termination of Bishnupur (ISTS) – Medinipur (ISTS) 400kV (Quad) line	400kV line bays: 2 no. [for termination of Bishnupur (ISTS)]

Sl. No.	Scope of the Transmission Scheme	Capacity/ km
		– Medinipur (ISTS) 400kV (Quad) line]

Implementation time-frame: 01-08-2028

7.4.3 Bihar, Odisha & West Bengal

(i) ERES-43 – Reconductoring (Farakka, Kahalgaon, Talcher & Meramunduli)

ER predominantly has thermal generations. During the peak solar hours in neighbouring regions of ER, backing down of thermal generations takes place in ER. Under such scenario, constraints are being observed on Kahalgaon (NTPC) – Farakka (NTPC) 400kV D/c line and Talcher (NTPC) – Meramundali (OPTCL) 400kV D/c line (one circuit LILOed at Angul and subsequently bypassed) under N-1.

The Kahalgaon – Farakka 400kV D/c line with thermal rating of 850MVA/ckt. During the peak solar hours loading of 400kV Kahalgaon – Farakka D/c remains above the N-1 security limit. During the backing down of generators of both ends the power flow through this line is above 650MW per circuit.

On the other side Due to frequent outage of HVDC Talcher – Kolar on forced outages/ tripping/ maintenance activities during the peak solar hours constraints in 400 kV Talcher – Meramundali lines. One circuit of Talcher – Meramundali 400kV D/c line was LILOed at Angul in the HCPTC-I project which was subsequently bypassed from Angul switchyard. Due to different length of both circuit uneven power flows through in both circuits. The power flow on the long line is about 300MW and shorter line is about 500MW. On many occasions, to facilitate any planned shutdown in the complex (N-1), generation back down at Talcher I & II, which are cheap pit-head plants, is required to be done to limit the power flow in the Talcher – Meramundali lines.

In view of above, to eliminate these constraints reconductoring of 400kV Kahalgaon – Farakka D/c line & 400 kV Talcher – Meramundali lines with HTLS conductor of 1228A ampacity was discussed and agreed in the 31st CMETS-ER held on 30-05-2024. Along with the reconductoring works, upgradation of associated 400kV line bay equipment at both ends of lines are also planned. Keeping in view urgent requirement of the scheme, the implementation timeframe of the scheme has been planned as 18 months with best effort basis schedule as 15 months.



Figure 7-3: Schematic of ERES-43

The scheme was approved in the 31st CMETS-ER held on 30-05-2024. Schematic is given at **Figure 7-3**

Sl. No.	Scope of the Transmission Scheme	Capacity (MVA) / Line length (km)/ Nos.
1.	Reconductoring of Kahalgaon (NTPC) – Farakka (NTPC) 400kV D/c (Twin Moose) line with Twin HTLS conductor (with ampacity of single HTLS as 1228A)	190ckm
2.	Reconductoring of Talcher (NTPC) – Meramundali (OPTCL) 400kV D/c (Twin Moose) line (one circuit via Angul and bypassed at Angul) with Twin HTLS conductor (with ampacity of single HTLS as 1228A)	140ckm
3.	Upgradation of associated 400kV bay equipment at Kahalgaon (NTPC)	Associated bay equipment with line capacity 3150A (as per standard equipment rating).
4.	Upgradation of associated 400kV bay equipment at Farakka (NTPC)	Associated bay equipment with line capacity 3150A (as per standard equipment rating).
5.	Upgradation of associated 400kV bay equipment at Talcher (NTPC)	Associated bay equipment with line capacity 3150A (as per standard equipment rating).
6.	Upgradation of associated 400kV bay equipment at Meramundali (OPTCL)	Associated bay equipment with line capacity 3150A (as per standard equipment rating).

Note:

- (a) NTPC and OPTCL to provide unconditional access to the ISTS licensee for upgradation of identified bay equipment at their respective substation / generation switchyard. The equipment released after replacement shall be handed over to NTPC and OPTCL on as is where is basis by the ISTS licensee.*
- (b) NTPC has already awarded R&M works for diameter 19-20-21 and 22-23-24 for some bay equipments at Farakka switchyard. Further, at Kahalgaon switchyard, R&M for some equipments of diameter 31-32-33 has also been awarded. ISTS licensee needs to coordinate with NTPC for replacement of balance equipments at Farakka and Kahalgaon switchyards as identified from Annexure-VII and Annexure-VIII (comprising of SLD and bay equipment details) respectively of the minutes of the 31st CMETS-ER.*
- (c) ISTS licensee needs to coordinate with NTPC and OPTCL for replacement of equipments at Talcher switchyard and Meramundali S/s respectively as identified from Annexure-V and Annexure-VI respectively (comprising of SLD and bay equipment details) of the minutes of the 31st CMETS-ER.*

Implementation time-frame: 03-04-2026

Page intentionally left blank

Chapter 8: North Eastern Region

North Eastern Region is the eastern-most region of India. It comprises seven states, the contiguous Seven Sister States. The region shares an international border with several neighbouring countries, China in the north, Myanmar in the east, Bangladesh in the south-west and Bhutan in the north-west. The NER has immense natural resources, accounting for 34% of the country's water resources and almost 40% of India's hydropower potential. The states in NER are well connected through EHV transmission links at 400kV level. The NER grid is further connected to other parts of the National Grid through 400kV HVAC lines as well as ± 800 kV, 6000MW Multi terminal Biswanath Chariali – Alipurduar – Agra HVDC link. During wet season (Monsoon period) hydro power is imported from Bhutan and during dry season (Winter period), surplus power is exported to meet their energy requirement. Cross-border interconnection with Bangladesh & Myanmar in North Eastern region helps these countries in meeting their energy requirement throughout the year.

8.1 Power Supply Scenario as on Aug'24

As on Aug'24, total Installed Capacity (IC) of North Eastern Region was 5497MW and the peak demand met was 3859MW. The state-wise breakup of installed capacity and peak demand is summarised at **Table 8-1** below.

Table 8-1: NER Installed Capacity and Peak Demand as on Aug'24

(All Fig in MW)

Region	Fossil			Non Fossil				Grand Total	Peak Demand
	Thermal	Gas	Total	Nuclear	Hydro	RES* (MNRE)	Total		
Assam	875	742	1616	0	522	215	737	2354	2,617
Arunachal Pradesh	37	47	84	0	545	155	700	784	198
Meghalaya	52	110	161	0	417	73	490	652	408
Tripura	56	487	543	0	68	36	105	648	386
Manipur	83	82	165	0	87	18	106	270	227
Nagaland	32	74	106	0	66	36	102	208	188
Mizoram	31	60	92	0	98	76	174	265	152
Central unallocated	113	64	176	0	140	0	140	316	
Total	1278	1665	2943	0	1944	610	2554	5497	3859

Source: CEA monthly report

8.2 Envisaged Power Supply Scenario by 2029-30

As per the 20th EPS, North Eastern Region demand for 2029-30 timeframe is expected to increase to 5835MW. As per the inputs received from various stakeholders, total installed

capacity of North Eastern Region for 2029-30 is expected to be 10723MW. The state wise bifurcation of installed capacity and peak demand is summarized below at **Table 8-2**.

Table 8-2: NER Installed Capacity and peak demand (2029-30)

(All Fig in MW)

State	Generation								Peak Demand	
	Fossil			Non Fossil				ESS		Grand Total
	Thermal	Gas	Total	Nuclear	Hydro	RES	Total			
Assam	0	0	0	0	24	100	124	0	124	3683
Arunachal Pradesh	0	741	741	0	893	1269	2162	0	2903	259
Meghalaya	0	0	0	0	120	0	120	0	120	546
Tripura	0	0	0	0	626	0	626	0	626	645
Manipur	0	0	0	0	32	0	32	0	32	404
Nagaland	0	0	0	0	48	0	48	0	48	221
Mizoram	0	237	237	0	0	0	0	0	237	289
Central	750	1254	2004	0	3630	1000	4630	0	6634	
NER	750	2232	2982	0	5372	2369	7741	0	10723	5835

There is a massive growth in peak demand of North Eastern Region from present time-frame (Aug 2024) to 2029-30 with a CAGR of 8.6%. The state wise peak demand growth is given at **Table 8-3**.

Table 8-3: Increase in Peak Demand of Various States of NER

(All Fig in MW)

State	Aug'24	2029-30	Increase in demand	CAGR
Assam	2618	3683	1065	7.1%
Arunachal Pradesh	198	259	61	5.5%
Meghalaya	408	546	138	6.0%
Tripura	386	645	259	10.8%
Manipur	227	404	177	12.2%
Nagaland	188	221	33	3.3%
Mizoram	152	289	137	13.7%
NER	3859	5835	1976	8.6%

From the above data it is observed that the CAGR growth of peak demand is maximum for Mizoram (13.7%) and minimum for Nagaland (3.3%). The CAGR of demand of NER is about 8.3% which is more than the National Average of 6%. In addition to above, 250MW demand of Myanmar & 160MW demand of Bangladesh is also considered as a part of North Eastern Region for the purpose of study.

8.3 Load Generation Balance for 2029-30 timeframe

In the chapter 3, All India Load Generation Balance (LGB) for identified nine scenarios was prepared as per the methodology finalized in consultation with CTU, CEA and Grid India. This section elaborates the North Eastern Region Load Generation Balance (LGB) for 2029-30 time-frame. For North Eastern Region also, three points on the daily load curve i.e. Solar max (afternoon), Peak load (evening) and Off-peak load (night) for three seasons viz. Monsoon (August), Summer (June) and Winter (February) have been considered.

Load generation balance has been prepared considering the generation despatch factors as mentioned at **Table 8-4** for the 9 scenarios. Further, thermal generators have been despatched as per the merit order.

Table 8-4: North Eastern Region Generation Dispatch and Demand Factors

Scenario No & Name	Generation Dispatch Factors			Demand Factors
	Hydro	Solar	Gas	
1-Aug Solar Max	70%	80%	0%	77%
2-Aug Peak Load	90%	0%	50%	76%
3-Aug Night Off Peak	70%	0%	50%	59%
4-Jun Solar Max	70%	85%	0%	70%
5-Jun Peak Load	90%	0%	50%	73%
6-Jun Night Off Peak	70%	0%	50%	62%
7-Feb Solar Max	30%	90%	0%	58%
8-Feb Peak Load	60%	0%	50%	77%
9-Feb Night Off Peak	30%	0%	30%	41%

8.4 ISTS Network Expansion Schemes evolved from Feb'24/Mar '24 to July'24

Various transmission schemes have been discussed/finalized in the Consultative Meeting for Evolution of Transmission System of North Eastern Region (CMETS-NER) from Feb'24/Mar '24 to July'24. The details of the schemes are summarized below in **Table 8-5**:

Table 8-5: Approved Transmission Schemes in this Rolling Plan

Sl. No.	Name of the Transmission Scheme	Scheme Type (RE/ Conventional/ Drawal incl strengthening)	Expected Timeframe	Tentative Cost (in ₹Cr.)	Quantum (MW)
Arunachal Pradesh					
1.	North Eastern Region Expansion Scheme – XXIII (NERES-XXIII) – 2 nd ckt Pasighat-Roing-Tezu-Namasai Corridor)	Strengthening	14 th Dec 2026	73.47	-
Assam					
1.	North Eastern Region Expansion Scheme – XXVI (NERES-XXVI) – Balipara Bus Reactor	Strengthening	14 th Dec 2025	35.79	-
2.	North Eastern Region Expansion Scheme – XXVIII (NERES-XXVIII) – VSR at Misa	Strengthening	14 th Mar 2026	52.71	-
Nagaland					
3.	North Eastern Region Expansion Scheme – XXVII (NERES-XXVII) – Reconductoring Dimapur, Kohima	Strengthening	14 th Sep 2025	0.3	-
Arunachal Pradesh & Assam					
1.	North Eastern Region Expansion Scheme – XXIX (NERES-XXIX) – Namsai ICT & Biswanath Chariali Reactor	Strengthening	April 2026	48.69	-
				~211	

8.4.1 Arunachal Pradesh

(i) NERES-XXIII - 2nd ckt Pasighat-Roing-Tezu-Namasai Corridor

Pasighat (Arunachal Pradesh) – Roing (POWERGRID) – Tezu (POWERGRID) – Namsai (POWERGRID) 132kV S/c on D/c corridor is owned by POWERGRID. Pasighat (Arunachal Pradesh) S/s is of DoP, Arunachal Pradesh and Roing, Tezu & Namsai substations are of POWERGRID.

DoP, Arunachal Pradesh informed that additional industrial demand of about 100MW (1st - 35MW and 2nd - 65MW) is expected at Niglok (Arunachal Pradesh) S/s. Niglok (Arunachal Pradesh) is connected to Napit/New Pasighat and Likbali substations of DoP, Arunachal Pradesh. POWERGRID, NERLDC and DoP, Arunachal Pradesh had mentioned that owing to hilly and difficult terrain conditions in Arunachal Pradesh, 2nd circuit stringing of Roing – Tezu – Namsai 132kV S/c on D/c line also needs to be taken up for reliable power supply in the area. Moreover, various new HEPs are coming up in Arunachal Pradesh in these areas which require construction power as well. Thus, keeping in view upcoming industrial demand, regular demand growth in eastern Arunachal Pradesh, and to improve reliability of 132kV system (predominantly S/c), it was agreed to take up 2nd circuit stringing of various intra-state [Gerukamukh – Likabali – Niglok – Pasighat (New)] and ISTS lines [Pasighat (Arunachal Pradesh) – Roing (POWERGRID) – Tezu (POWERGRID) – Namsai (POWERGRID)].

The ISTS portion of the scope under subject scheme was finalized after detailed consultation in the 29th CMETS-NER held on 28-03-2024. Map is given at **Figure 8-1**

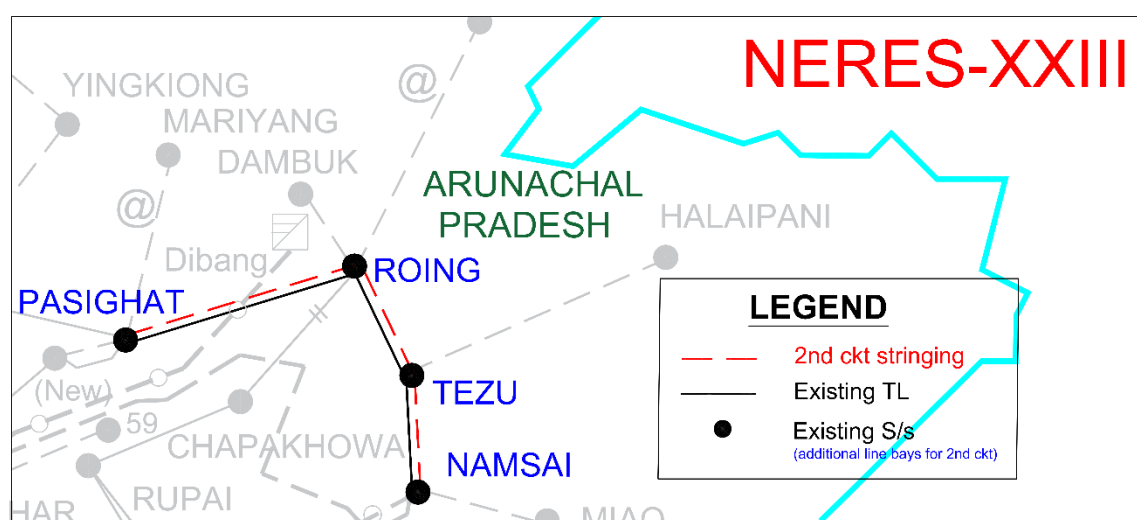

Figure 8-1: Schematic NERES-XXIII

Sl. No.	Scope of the Transmission Scheme	Capacity/ km
1.	Stringing of 2 nd circuit of Pasighat (Arunachal Pradesh) – Roing (POWERGRID) 132kV S/c on D/c line with ACSR Panther conductor commensurate with rating and maximum operating temperature of 1 st circuit	103km

Sl. No.	Scope of the Transmission Scheme	Capacity/ km
2.	Stringing of 2 nd circuit of Roing (POWERGRID) – Tezu (POWERGRID) 132kV S/c on D/c line with ACSR Panther conductor commensurate with rating and maximum operating temperature of 1 st circuit	73km
3.	Stringing of 2 nd circuit of Tezu (POWERGRID) – Namsai (POWERGRID) 132kV S/c on D/c line with ACSR Panther conductor commensurate with rating and maximum operating temperature of 1 st circuit	95.24km
4.	Extension at Pasighat (DoP, Arunachal Pradesh) [@] : 1 no. 132kV AIS line bay for termination of 2 nd circuit of Pasighat (Arunachal Pradesh) – Roing (POWERGRID) 132kV D/c line	132kV AIS line bay: 1 no.
5.	Extension at Roing (POWERGRID) S/s: 2 no. 132kV AIS line bay for termination of 2 nd circuit of Pasighat (Arunachal Pradesh) – Roing (POWERGRID) 132kV D/c line and 2 nd circuit of Roing (POWERGRID) – Tezu (POWERGRID) 132kV D/c line	132kV AIS line bay: 2 no.
6.	Extension at Tezu (POWERGRID) S/s: 2 no. 132kV AIS line bay for termination of 2 nd circuit of Roing (POWERGRID) – Tezu (POWERGRID) 132kV D/c line and 2 nd circuit of Tezu (POWERGRID) – Namsai (POWERGRID) 132kV D/c line	132kV AIS line bay: 2 no.
7.	Extension at Namsai (POWERGRID) S/s: 1 no. 132kV AIS line bay for termination of 2 nd circuit of Tezu (POWERGRID) – Namsai (POWERGRID) 132kV D/c line	132kV AIS line bay: 1 no.

Implementation time-frame: 14-12-2026

8.4.2 Assam

(i) NERES-XXVI – Balipara Bus Reactor

Presently, 2x50MVAR + 2x80MVAR (installed in parallel) + 1x125MVAR bus reactors are available at Bongaigaon (POWERGRID) S/s at 400kV voltage level. Out of which 50MVAR Bus Reactors - I & II were commissioned in 1987 & 1994 respectively. After serving more than 29 years, it has been observed that the reactors are continuously giving problems. For further assessment of the health, matter was referred by POWERGRID to CPRI, Bangalore for Residual Life Assessment. After reviewing all parameters, CPRI has opined for replacement of the subject bus reactor.

On annual basis at Bongaigaon 400kV bus, average of minimum voltage is about 402kV, and average bus voltage is about 409kV. Accordingly, in order to keep the bus voltage near nominal levels, the existing quantum of reactive compensation is required to be maintained. As per the study, it was observed that new reactors of 50MVAR may not be installed due to their reduced capability in changing bus voltage upon switching. Thus, a new 125MVAR bus reactor has been

planned to be installed in one of the vacated bus reactor bays after decommissioning of old 2x50MVAR bus reactors. Further, as the existing 2x80MVAR bus reactors are installed in parallel, one of these 80MVAR bus reactors is planned to be installed in the other vacated bay after decommissioning of 2x50MVAR bus reactors. After decommissioning of old 2x50MVAR bus reactor and commissioning of new 1x125MVAR, there would be 2x80MVAR + 2x125MVAR bus reactors at Bongaigaon (POWERGRID) S/s and all bus reactors would be installed in separate bays.

The above proposal was agreed in the 22nd CMETS-NER held on 28-08-2023. Map is given at **Figure 8-2.**

Sl. No.	Scope of the Transmission Scheme	Capacity/ km
1.	Decommissioning of existing 420kV, 50MVAR (bus reactor-1) and installation of new 420kV, 125MVAR bus reactor in its place along with replacement of associated main and tie bay equipment at Balipara (POWERGRID) S/s	<ul style="list-style-type: none"> 420kV, 1x125MVAR Bus Reactor: 1 no. Replacement of 400kV main & tie bay equipment of bus reactor diameter

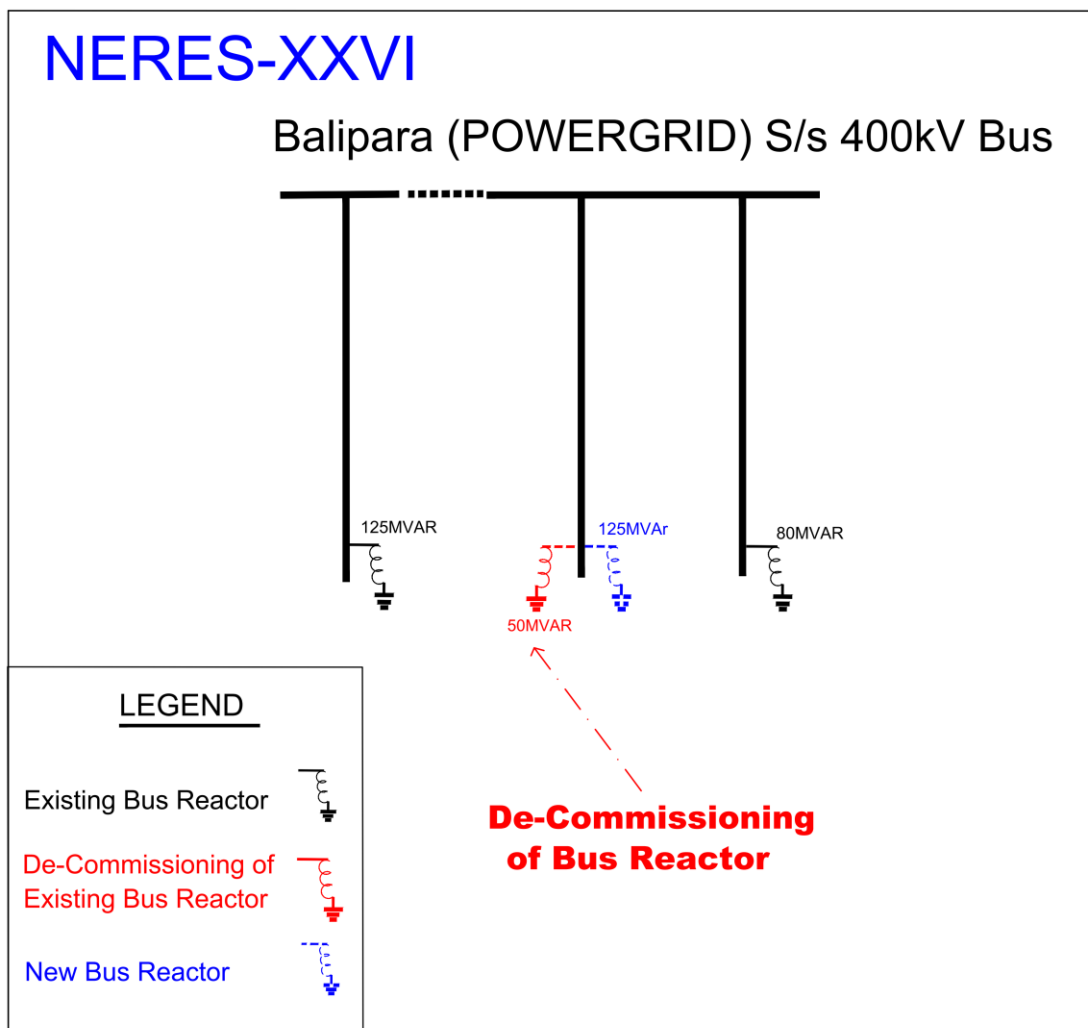

Figure 8-2: Schmeatic NERES-XXVI

Implementation time-frame: 14-12-2025**(ii) NERES-XXVIII – VSR at Misa**

Presently, 1x50MVAR + 1x80MVAR, 420kV Bus reactors are installed at Misa (POWERGRID) 400/220kV S/s. Additionally, 36kV, 4x25MVAR bus reactors are also installed in tertiary of 400/220/33kV ICT at Misa (POWERGRID) S/s.

These tertiary reactors are almost 24 to 28 years old and as informed by POWERGRID, there is no support from OEM. Due to ageing, the conditions of these tertiary reactors have deteriorated, and heavy oil leakages are frequently reported even after gasket replacements. In recent time, it is observed that even with the 4x25MVAR tertiary bus reactors, maximum voltage at 400kV bus is in the range of 415kV to 418kV and 25% of time it is above nominal voltage level. After decommissioning of tertiary reactors, the voltage at Misa S/s will increase further. Accordingly, it was suggested that with decommissioning of tertiary reactors, additional bus reactor may be planned at Misa S/s.

Accordingly, decommissioning of existing 36kV, 4x25MVAR bus reactors installed in tertiary of 400/220/33kV ICT(s) at Misa S/s and installation of new 420kV, 1x125MVAR Bus Reactor with associated GIS bay at Misa (POWERGRID) S/s was discussed and agreed in the 29th CMETS-NER held on 28-03-2024.

Subsequently, installation of VSR was identified by CTU in place of Bus Reactor to provide variable reactive power support at Misa S/s. The matter regarding installation of VSR in place of normal bus reactor at Misa (POWERGRID) S/s may be ratified in the forthcoming meeting of CMETS-NER. Accordingly, the matter was discussed in the 31st CMETS-NER held on 29.05.2024, wherein, it was agreed to install new 420 kV, 1x125 MVAR Variable Shunt Reactor (VSR) having variable range from 63MVAR to 125MVAR (with at least 25 tap positions) along with associated GIS bay at Misa (POWERGRID) S/s in place of normal bus reactor at Misa (POWERGRID) S/s.

Accordingly, decommissioning of existing 36kV, 4x25MVAR bus reactors installed in tertiary of 400/220/33kV ICT(s) at Misa S/s and installation of new 420kV, 1x125MVAR (having variable range from 63MVAR to 125MVAR with at least 25 tap positions) VSR with associated GIS bay at Misa (POWERGRID) S/s was discussed and agreed in the 31st CMETS-NER held on 29-05-2024. Map is given at **Figure 8-3**.

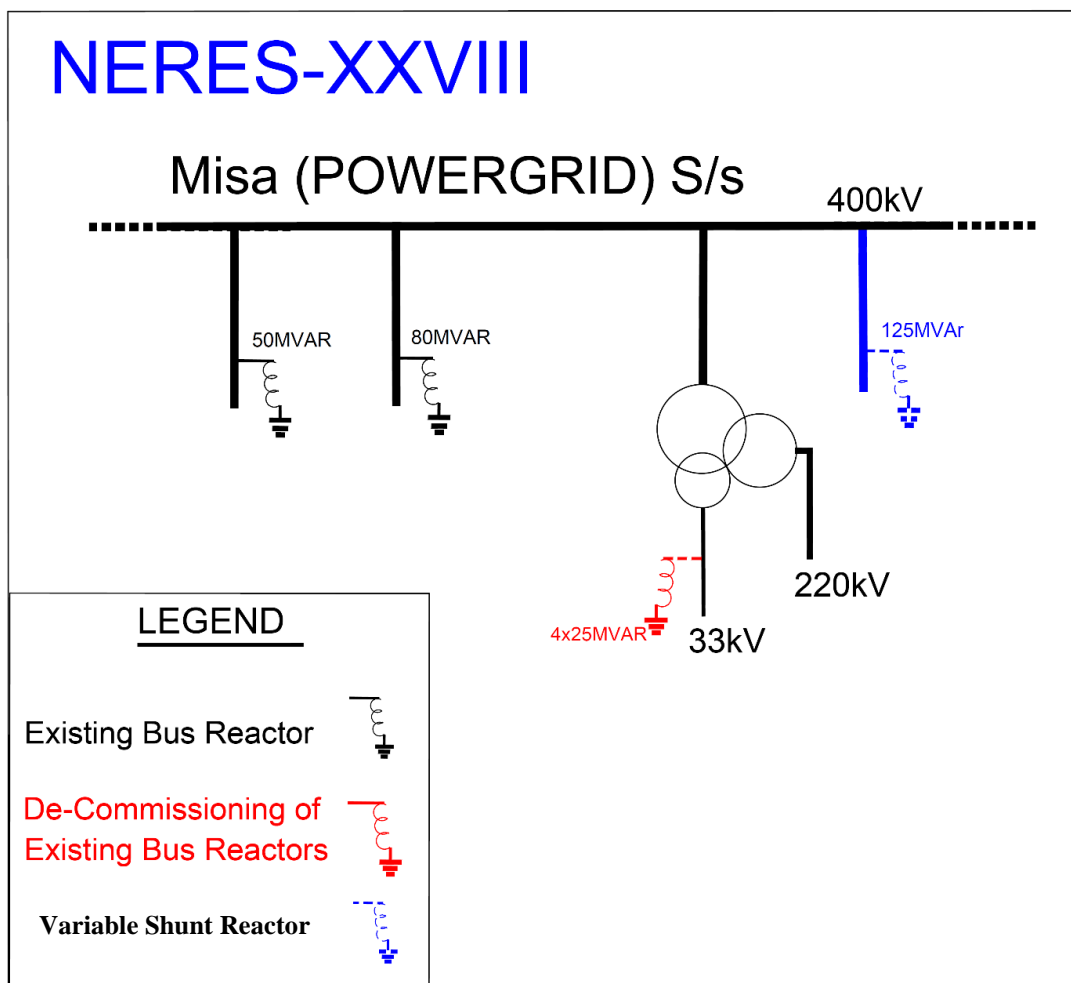

Figure 8-3: Schematic NERES-XXVIII

Sl. No.	Scope of the Transmission Scheme	Capacity (MVA) / Line length (km)/ Nos.
1	Installation of new 420 kV, 1x125 MVAR, 3-Ph Variable Shunt Reactor (VSR) having variable range from 63MVAR to 125MVAR (with at least 25 tap positions) along with associated GIS bay at Misa (POWERGRID) S/s	<ul style="list-style-type: none"> 420 kV, 1x125 MVAR VSR (having variable range from 63MVAR to 125MVAR with at least 25 tap positions): 1 No. 400 kV VSR bay (GIS): 1 No. (with two circuit breakers)[@] 400kV GIB: 1000m (approx.)
<p><i>Note:</i> [@] In view of space constraints for GIS extension and space constraint towards usage of other bay of one and half breaker scheme, VSR is planned to be installed in double bus scheme with two circuit breakers.</p>		

Implementation time-frame: 14-03-2026

8.4.3 Nagaland

- (i) NERES-XVII - Reconductoring Dimapur, Kohima

Dimapur (DoP, Nagaland) – Kohima (DoP, Nagaland) 132kV S/c line of DoP, Nagaland was LILOed by POWERGRID under ISTS at Dimapur (POWERGRID) S/s, resulting in formation of Dimapur (POWERGRID) – Dimapur (Nagaland) ckt-2 and Dimapur (POWERGRID) – Kohima (DoP, Nagaland) 132kV S/c lines, which became partly owned by DoP, Nagaland and partly owned by POWERGRID.

The conductor of Dimapur (DoP, Nagaland) – Dimapur (POWERGRID) and Dimapur (POWERGRID) – Kohima (DoP, Nagaland) 132kV lines are very old (commissioned around 1970) and their thermal rating is of the order of 40MVA only (degraded). Upon outages of Kohima (DoP, Nagaland) – Karong (MSPCL) & Doyang – Wokha 132kV S/c lines, high loadings are observed in Nagaland intra-state system. Dimapur (DoP, Nagaland) is fed radially from ISTS substation through two single circuit lines and if one circuit of Dimapur (POWERGRID) – Dimapur (DoP, Nagaland) is out, the other circuit would also trip on overloading. The demand at Dimapur is expected to reach 130MW in next 2 years and for reliable power supply reconductoring of Dimapur (POWERGRID) – Dimapur (Nagaland) ckt-1 & ckt-2 is required. Ckt-1 is owned by DoP, Nagaland and ckt-2 is jointly owned by DoP, Nagaland and POWERGRID.

In view of the above, to strengthen the power supply situation in major cities of Nagaland viz. Kohima and Dimapur, reconductoring of Dimapur (POWERGRID) – Dimapur (Nagaland) ckt-1 & ckt-2 and Dimapur (POWERGRID) – Kohima (DoP, Nagaland) 132kV S/c lines with HTLS conductor of 800A ampacity was discussed and agreed in the 29th CMETS-NER held on 28-03-2024. Reconductoring of ISTS portion of these lines are being taken up under this scheme. DoP, Nagaland shall reconductor their portion of lines in matching time-frame.

The ISTS portion of the scope under subject scheme was finalized after detailed consultation in the 29th CMETS-NER held on 28-03-2024. Map is given at **Figure 8-4**

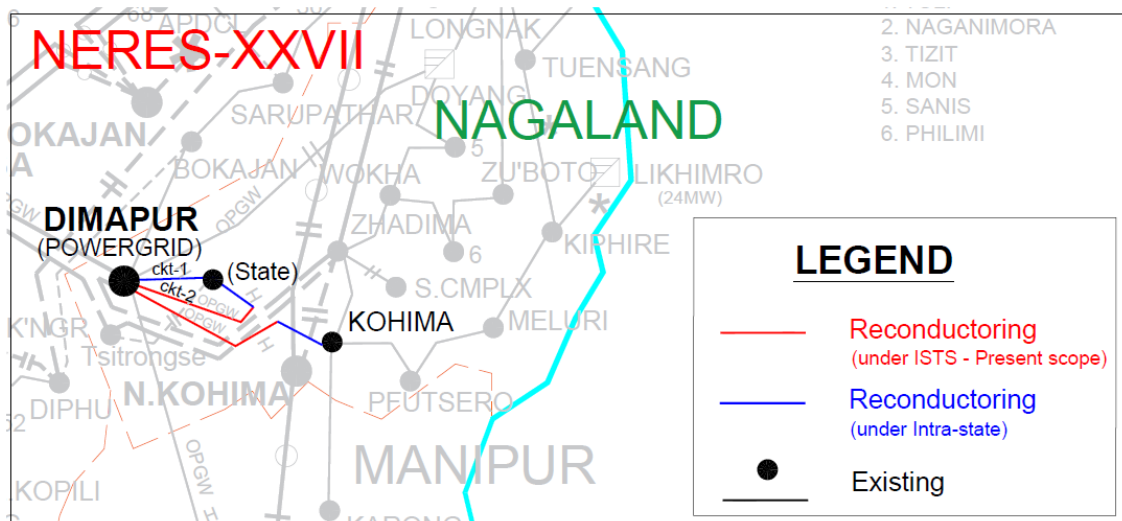

Figure 8-4: Schematic NERES-XXVII

Sl. No.	Scope of the Transmission Scheme	Capacity /km
(a)	Reconductoring of ISTS portion of Dimapur (POWERGRID) – Dimapur (DoP, Nagaland) 132kV (ckt-2) ACSR Panther S/c line with Single HTLS conductor of 800A	0.335km
(b)	Reconductoring of ISTS portion of Dimapur (POWERGRID) – Kohima (DoP, Nagaland) 132kV ACSR Panther S/c line with Single HTLS conductor of 800A	0.335km

Implementation time-frame: 14-09-2025

8.4.4 Arunachal Pradesh & Assam

(i) NERES-XXIX (Namsai ICT & Biswanath Chariali Reactor)

a) 1x50MVA, 132/33kV (3rd) ICT at Namsai (POWERGRID) S/s along with associated bays

132/33kV Namsai S/s is owned by POWERGRID. At present there are 2x15MVA ICT at this substation. DoP Arunachal Pradesh mentioned that presently the total load at Namsai area is about 13MW out of which 9MW is met through Namsai (POWERGRID) S/s and 4MW is met through Rupai – Namsai 33kV old line. The load at Namsai is expected to reach to about 17MW by Mar 2027. Rupai – Namsai 33kV line was implemented long back to supply power to Namsai area when 132kV was not available. Now, Namsai is one of the fastest growing load centres in Arunachal Pradesh due to improvement in road and other infrastructures. Accordingly, for reliable and power supply 4MW load is also fed from ISTS S/s and the old 33kV line is made to be defunct. Thus, there shall be drawl requirement of about 17MW in next few years at Namsai (POWERGRID) S/s, which would not be N-1 compliant. Further, as per CEA's "Standard Specifications and Technical Parameters for Transformers and Reactors (66 kV & above Voltage Class)" published in April 2021, the minimum standard rating of 132/33kV, 3-phase ICT is of 31.5MVA. Presently there are two different rating of 132/33kV ICTs in NER viz. 1-phase 5MVA and 3-phase 50MVA. To meet the contingency requirement in case of failure of ICT, spare 50MVA ICT is also available in the region and presently kept at Nirjuli S/s. Accordingly, a new 1x50MVA ICT was proposed and agreed in 33rd CMETS-NER held on 26-07-2024.

b) 420kV, 125MVAr Bus Reactor at Biswanath Chariali (POWERGRID) S/s along with associated bays

During winter season, monopole operation in reverse direction of Agra to BNC HVDC link is being carried out with metallic return mode through the conductor of the other pole. Therefore, voltage on metallic return conductor has been negligible which results of theft of line materials like spacer, corona ring etc. Theft of hundreds of spacer-dampers has been experienced in the past which leads to damage of conductor fittings and accessories and chance of conductor snapping increases. Accordingly, a solution was

proposed to operate in Bipole mode during reverse power flow (Agra to BNC) during winter season.

Presently at BNC there are 4 no. of 63MVAR switchable line reactor connected in BNC – Lower Subansiri 400kV 2xD/c line which are being used as Bus Reactor as generation is not commissioned. After studies it was observed that, During charging of 1st circuit of Biswanath Chariali (POWERGRID) – Lower Subansiri 2xD/c line (along with 63MVAR switchable line reactor at BNC end), about 3.5kV voltage rise is observed at BNC end and upon charging of all four circuits from BNC to LS, total about 14-15kV rise is observed at BNC end. Subsequently, upon charging of 1x80MVAR Bus reactor at Lower Subansiri end, voltage drop by about 4kV at BNC end and with 2x80MVAR Bus reactor voltage drop by about 8kV at BNC end was observed. Further, with new 1x125MVAR Bus reactor at BNC, the voltage drop is observed to be about 6kV at BNC end. So overall voltage at BNC end comes back to its original voltage level with additional 125MVAR bus reactor. According due to operational requirements an additional 1x125MVAR, 420kV bus reactor at BNC (POWERGRID) S/s was agreed in the 31st CMETS-NER held on 29-05-2024. Maps is given at **Figure 8-5 & Figure 8-6.**

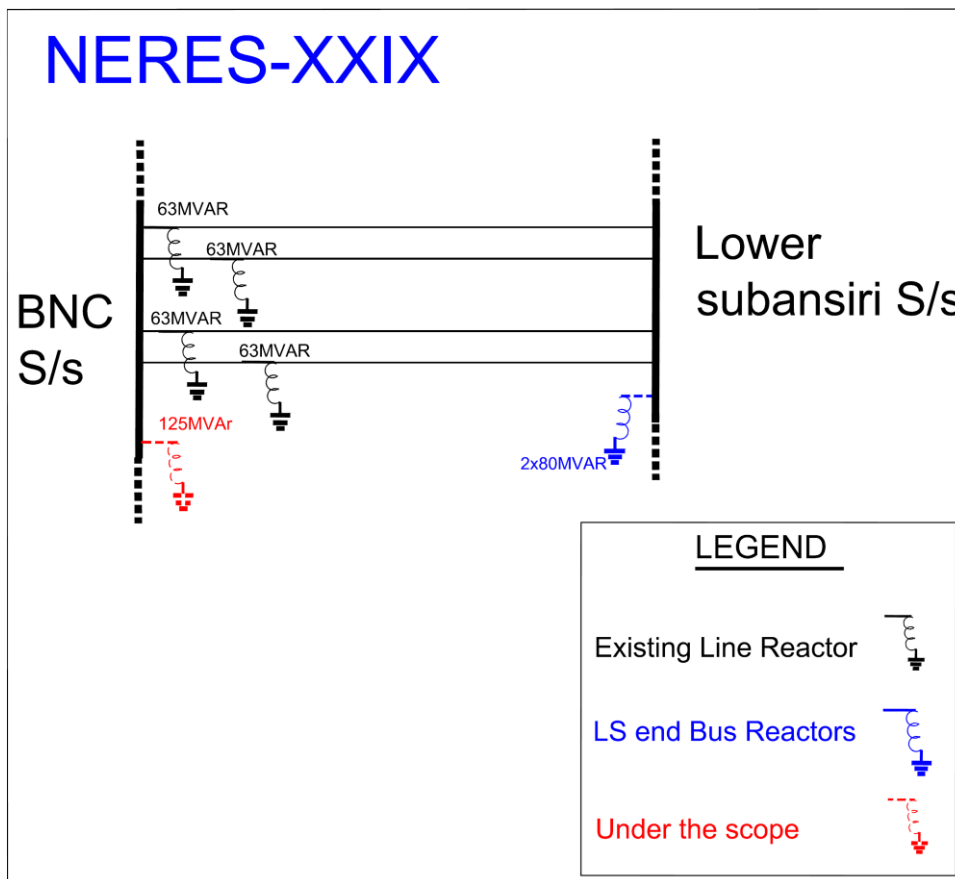

Figure 8-5: Schematic NERES-XXIX (Biswanath Chariali Reactor)

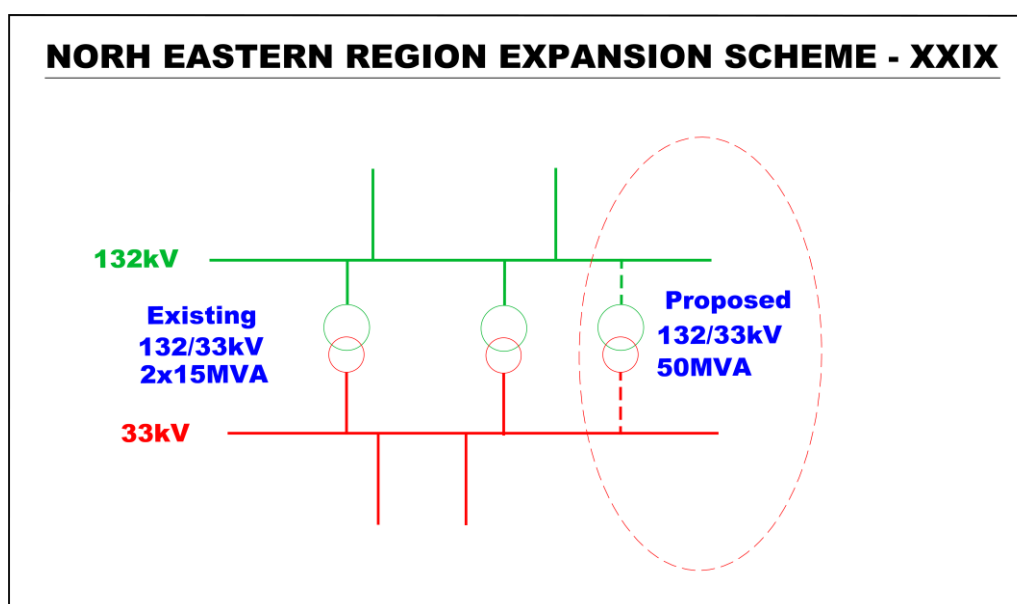

Figure 8-6: Schematic NERES-XXIX (Namsai ICT)

Sl. No.	Scope of the Transmission Scheme	Capacity/ km
1.	Installation of new 1x50MVA, 132/33kV (3 rd) ICT at Namsai (POWERGRID) S/s along with associated bays.	<ul style="list-style-type: none"> • 50MVA, 132/33kV ICT: 1 no. • 132kV ICT bays: 1 no. • 33kV ICT bays: 1 no.
2.	Installation of new 420kV, 125MVAr Bus Reactor at Biswanath Chariali (POWERGRID) S/s along with associated bays.	<ul style="list-style-type: none"> • 420kV, 125MVAr Bus Reactor: 1 no. • 400kV reactor bay: 1 no. (main and tie bay in AIS)

Implementation time-frame: April 2026

Chapter 9: Cross-Border Interconnection

Due to geographical location, India shares its boundaries with many South Asian countries and can play an important role in exchange of power to these countries for optimal utilisation of resources in particular and development of economy in general. Transmission of power is economical than transportation of fuel. Towards this, it is important to establish electrical interconnections with neighbouring countries which would be beneficial in meeting growing power demand, sharing of various types of energy resources, decreasing operational cost through better resource management, utilizing renewable energy resources and deferring investment by optimizing spinning reserve.

The details of existing, under-construction and under-discussion interconnections with the neighbouring countries viz. Bangladesh, Bhutan, Myanmar, Nepal & Sri Lanka with Indian grid to facilitate transfer of power for the benefit of both sides is given below:

9.1 India-Bangladesh

(i) Present interconnection

- 1160MW is being transferred to Bangladesh through following two links:
 - *1000MW through Baharampur (India) – Bheramara (Bangladesh) 400kV 2xD/c line along with 2x500MW HVDC Back-to-Back terminal at Bheramara.*
 - *160MW through Surajmaninagar (Tripura) – North Comilla (Bangladesh) – South Comilla 400kV D/c radial interconnection (operated at 132kV).*

(ii) Planned interconnection

- *Katihar (Bihar) – Parbotipur (Bangladesh) – Bornagar (Assam) 765kV D/c line*
India is going ahead with the financing and construction of the entire cross border link. The Bangladesh side may synchronize through this link at Parbotipur at an appropriate time for 1000MW drawl of power.

9.2 India-Bhutan

(i) Present interconnection

- 2311MW is being transferred from Bhutan to India through following lines in synchronous mode of operation
 - *Kurichu HEP – Geylephu (Bhutan) – Salakati 132kV S/c*
 - *Deothang/Motonga – Rangia 132kV S/c*
 - *Chukha HEP – Birpara 220kV (3 circuits)*
 - *Tala HEP – Siliguri 400kV 2xD/c*
 - *Mangdechu HEP (Bhutan) – Jigmeling (Bhutan) – Punatsangchuu-I&II HEP (bypassed as generations are delayed) – Alipurduar 400kV D/c (Quad) line*

- *Jigmeling (Bhutan) – Alipurduar 400kV D/c (Quad) line*

(ii) Under Construction interconnection

- With the commissioning of Punatsangchu-I and II generation by 2025-26 & Dec 2024 (*as per latest available report on CEA website*), the power transfer capacity would increase to about 4531MW.

9.3 India-Myanmar

(i) Present interconnection

- About 2-3 MW power is being supplied to Tamu (Myanmar) from Moreh (Manipur) 33/11kV, 5MVA substation through 11kV line in radial mode.

(ii) Under Discussion interconnection

- Imphal (India) - Tamu (Myanmar) high capacity AC line along with 1x500MW HVDC back-to-back
- Nampong (Arunachal Pradesh, India) - Pansong (Myanmar) 11kV S/c radial line
- Behiang (Manipur, India) - Cikha (Myanmar) 11kV S/c radial line
- Zokhawthar (Mizoram, India) - Rikhawdar (Myanmar) 11kV S/c radial line

9.4 India-Nepal

(i) Present interconnection

- 1400MW can be transferred from India to Nepal through following links in radial mode of operation:
 - *About 600MW through 132kV & below radial lines*
 - *About 800MW of power through the first high-capacity link i.e., 400kV D/c Dhalkebar (Nepal) – Muzaffarpur (India) line.*

(ii) Under Construction interconnection

- Additional about 1900MW can be transferred from Nepal to India through following links:
 - Sitamarhi (POWERGRID) – Dhalkebar (Nepal) 400kV D/c (Quad) line (associated with Arun-3 HEP, Nepal): Expected by Dec 2023 – 800MW
 - Gorakhpur (India) – New Butwal (Nepal) 400kV D/c (Quad) line: Requisite approvals are being obtained to take up implementation. – 1000MW
 - Nanpara (India) - Kohlapur (Nepal) 132kV D/c line – 50MW

(iii) Under Discussion interconnection

- New Purnea (India) - Inaruwa (Nepal) 400kV (Quad) D/c line – 1500MW
- Bareilly New (India) - Lumki (Nepal) 400kV (Quad) D/c line – 1500MW
- Upgradation of Tanakpur – Mahendranagar 132 kV Corridor or new Corridor from Nepal to Jauljivi (India) is being explored

9.5 India-Sri Lanka

(i) Under Discussion interconnection

- ±320kV, 1000MW Madurai-New (India) to Mannar (Sri Lanka) HVDC line (overhead) along with 500MW VSC based HVDC terminals at both ends

The cross-border transmission capacity of India with neighbouring countries in present time-frame and through under construction interconnections is summarized below in Table 9-1:

Table 9-1: Cross-border power transfer capacity by 2029-30

(All fig in MW)

Country	Existing	Under Construction	Planned	Total
India-Bangladesh	1160	0	1000	2160
India-Bhutan	2311	2220	0	4531
India-Myanmar	3	0	504	507
India-Nepal	1400	1900	3000	6300
India-Sri Lanka	0	0	500	500
Total	4874	4120	5004	13998

A schematic of the existing, under-construction and proposed cross-border interconnections is given in **Figure 9-1** below:

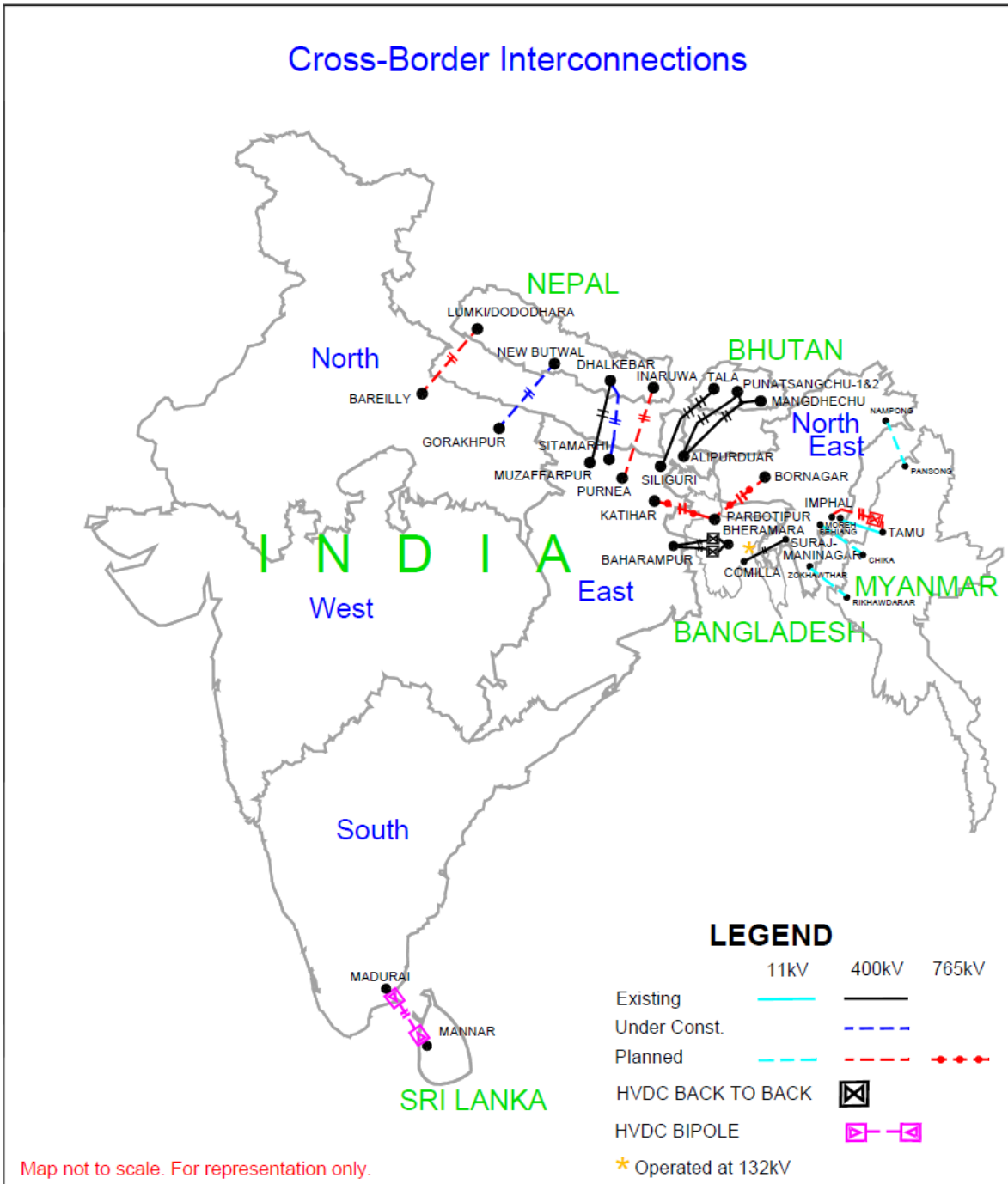

Figure 9-1 Cross-Border interconnections

In addition to above, discussions/feasibility for interconnections with other countries like Saudi Arabia, UAE, Singapore & Maldives are also going on for identification of new Cross Border interconnections.

Chapter 10: Conclusion

The installed capacity of generation in Indian grid is expected to increase to about 776 GW including ESS by 2029-30 from 450 GW as on Aug'24. It will witness an increase in contribution of non-fossil fuel-based energy sources from 46% to 60%, whereas contribution of fossil fuel-based energy source will see a decline from 54% to 40% in total installed capacity in same timeframe. This will create a pathway for India's commitment in COP26, wherein India is projected to have total installed capacity of non-fossil fuel-based generation of 500GW by the year 2030.

Power scenario of the country is quite diverse and varies continuously. RE integration with grid further enhance its complexity. Large RE complexes are expected to be established in Northern, Western, and Southern regions by 2029-30 time-frame. The transmission system for integrating the same into the grid has already been planned and is currently under various stages of approval/implementation. As substantial solar generation addition has been envisaged in Rajasthan, this has resulted in NR becoming exporter of power around noon solar max period and importer during the evening peak demand period, in all seasons. Further due to large RE integration in SR also, it is expected to export RE power in maximum scenarios except winter season. Similar situations have been witnessed in other regions as well i.e. the region is surplus under certain load-generation scenario and deficit in other. To study the seasonal and diurnal variations of generations including demand, load generation balance has been prepared for three seasons (Monsoon, Summer, and Winter) in a year with three load conditions (Solar max, Evening peak demand, and Night off-peak demand) of daily load curve for each season. All India maximum and minimum demand of 368 GW and 234 GW after accounting an additional demand of Green Hydrogen/Ammonia of about 22 GW and of other bulk consumers of about 18 GW as direct drawl from ISTS has been considered while working out the LGBs for 2029-30 timeframe.

While preparing the LGB, it has been observed that to dispatch maximum RE generation during the noon time, on bar thermal units required to meet evening peak demand are to be operated below the present technical minimum of 40% which highlights the need of energy storage in the grid to facilitate the RE integration by 2029-30. As of now, the portion of energy and peak demand met by RE as compared to total requirement is quite low. However, this will not be the case of future when a large quantum of RE will integrate with grid.

Brief of transmission systems evolved for each region are as below:

Northern Region (NR)

The total installed generation capacity of NR as on Aug'24 is about 128.9 GW which constitute capacity from fossil sources (49.8% share) & balance (50.2% share) from Non-fossil sources in which (48%) contribution in total regional IC is from renewable generation capacity including hydro and balance (1%) is from nuclear.

NR is connected to WR and ER through 765kV & 400kV high capacity corridors along with HVDC Back to Back / HVDC Bipoles. The thermal generating stations of NR are predominantly located in Uttar Pradesh, Punjab, Rajasthan and Haryana, whereas hydro generation is concentrated in Jammu & Kashmir, Himachal Pradesh and Uttarakhand. Further, Rajasthan is a RE rich state comprising of large Solar & Wind capacity.

To meet the growing demand, NR is continuously progressing in generation capacity addition majorly through hydro and non-conventional/renewable sources. As per the 20th EPS, NR demand for 2029-30 timeframe is expected to increase to about 116.7 GW. As per the inputs received from various stakeholders, total installed capacity of NR for 2029-30 is expected to be about 220 GW.

Various transmission schemes i.e. Transmission system for evacuation of power from Fatehgarh/Barmer Complex as part of Rajasthan REZ Ph-IV (Part-4 :3.5 GW) [Fatehgarh/Barmer Complex], Transmission system for evacuation of power from Rajasthan REZ Ph-V (Part-1 :4 GW) [Sirohi/Nagaur] Complex, Transmission scheme, Transmission system strengthening to facilitate evacuation of power from Bhadla/Bikaner complex, Transmission scheme for evacuation of power from Ratle HEP (850 MW) & Kiru HEP (624 MW), Augmentation of 400/220kV ICTs at Bassi, Bhiwadi, Bikaner-II, Fatehgarh-IV, Barmer-I, Bikaner, Fatehgarh-II, Malerkotla & 400 kV line bay at Bhadla-III PS planned in the Consultation Meeting for Evolution of Transmission System in Northern Region (CMETS-NR) from Feb'24/Mar'24 to Feb'24 for implementation. In this Rolling Plan, 13 nos. of transmission schemes of about 3,935 ckm of transmission lines and 23902 MVA of transformation capacity has been formulated at an estimated cost of Rs. 19,535.1 Cr.

Thus, cumulatively by 2029-30, transmission schemes comprising of 26,722 ckm of transmission lines and transformation capacity of 1,81,120 MVA at estimated cost of Rs 1,41,850 Cr. is expected to be added in the grid.

Western Region (WR)

The total installed generation capacity of WR as on Aug'24 is about 149GW which constitute capacity from fossil sources (58% share) & balance (42% share) from Non-fossil sources comprising of nuclear, renewable generation capacity including hydro.

Western Region is connected to Northern, Southern and Eastern Regions through 765kV & 400kV high-capacity corridors along with Back to Back HVDCs and Bi-Pole HVDC links. The thermal generating stations of Western Regions are predominantly concentrated in the coal rich states of Chhattisgarh, Eastern part of Maharashtra and Madhya Pradesh. Further, Gujarat, Maharashtra and Madhya Pradesh are RE rich states comprising of large Solar & Wind capacity. Western part of Maharashtra, southern Gujarat and DD & DNH have high demand and less internal generation.

To meet the growing demand, Western region is continuously progressing in generation capacity addition majorly through thermal and non-conventional/renewable sources. The peak demand of Western Region for 2029-30 timeframe is expected to increase to about 107 GW.

In addition to above, the demand of about 22 GW corresponding to green hydrogen/ green ammonia, bulk consumer / distribution licensees is expected to be added to the grid by 2029-30. As per the inputs received from various stakeholders, total installed capacity of Western Region for 2029-30 is expected to be about 247 GW.

Various transmission schemes from Feb'24/Mar'24 to July'24 have been evolved such as Transmission System for Evacuation of power from various potential renewable energy zone in Khavda area of Gujarat under Phase-V, Transmission System for Offshore Wind Zone (500MW) Phase-1, Augmentation at Bhuj-I PS, Raghnesda, Lakadia PS, Rajgarh, Neemuch, Network Expansion scheme in Western Region to cater to Pumped storage potential near Talegaon (Pune) and is expected to play a major role in fulfilling India's vision of generating 500 GW of non-fossil generation capacity by 2030. Additionally, transmission system to cater to the power requirement of the upcoming Green Hydrogen and Green Ammonia manufacturing hubs in Western Region by 2029-30 (3GW at Navinal (Mundra) and 3GW at Kandla) has also been planned as a part of the Hydrogen Mission announced by Hon'ble Prime Minister of India on 15th August 2021.

In this Rolling Plan, 25 nos. of transmission schemes of about 3100 ckm of transmission lines and transformation capacity of 49,130 MVA have been formulated at an estimated cost of Rs. **28,440 Cr.** These schemes either have been approved or are under various stages of approval. Further, new network expansions in Western Region are being taken up on a continuous basis.

Thus, cumulatively by 2029-30, transmission schemes comprising of **15,229 ckm** of transmission lines and transformation capacity of **1,79,730 MVA** at an estimated cost of Rs **1,23,236 Cr.** is expected to be added in the grid.

Southern Region (SR)

The total installed generation capacity of SR as on Aug'24 is about 131 GW which constitute capacity from fossil sources (46% share) & balance (54% share) from Non-fossil sources in which (50%) contribution in total regional IC is from renewable generation capacity including hydro and balance (3%) is from nuclear.

Southern Region is connected to Western and Eastern Regions through high capacity 765kV AC links, Back-to-Back HVDC and Bi-pole HVDC links. The thermal generating stations of Southern Region are predominantly concentrated in the States of Tamil Nadu, Karnataka, Andhra Pradesh and Telangana. Further, Tamil Nadu, Karnataka and Andhra Pradesh are RE rich states comprising of large scale Solar & Wind capacity. Southern part of Karnataka (Bangalore), Kerala and Central part of Telangana (Hyderabad) has high demand and less internal generation.

To meet the growing demand, Southern Region is continuously progressing in generation capacity addition majorly through thermal and non-conventional/renewable sources. Southern Region demand for 2029-30 timeframe is expected to increase to about 97 GW. As per the inputs received from various stakeholders, total installed capacity of Southern Region for 2029-30 is expected to be about 229 GW.

Various transmission systems have been evolved in the Consultation Meeting for Evolution of Transmission System in SR (CMETS-SR) from Feb/Mar'24 to Jul'24 for implementation. These schemes have either been approved or under various stages of approval. Transmission system for integration of additional RE potential of about 17.5 GW in Kurnool, Ananthapur, Bidar, Davanagere & Tumkur area have been evolved. The proposed scheme will facilitate integration and immediate evacuation of RE potential areas of Karnataka, Andhra Pradesh and Tamil Nadu which are under various stages of approval. Transmission System for prioritized 0.5 GW Offshore wind farms in Tamil Nadu has been evolved as a major step towards development of Off shore wind in India. Further, transmission system for 6 GW has been evolved for facilitating integration of Green hydrogen/ Green ammonia based bulk consumers in Southern Grid in Kakinada & Tuticorin area. In addition to the above schemes for RE based generation and GH projects, system strengthening of ISTS transmission system in the form of ICT augmentation at Bidadi, Yelahanka and N'Sagar has been evolved for removal of constraints.

In this Rolling Plan, 15 nos. of transmission schemes of about 2730 ckm of transmission lines and transformation capacity of 50,630 MVA have been formulated at an estimated cost of Rs. 23,760 Cr. These schemes either have been approved or are under various stages of approval. Further, new network expansions in Southern Region are being taken up on a continuous basis and the mitigation measures identified would be taken up for detailed analysis.

Cumulatively by 2029-30, transmission schemes comprising of 7,400 ckm of transmission lines and transformation capacity of 1,27,630 MVA at estimated cost of Rs 47,975 Cr. is expected to be added in the grid.

Eastern Region (ER)

The total installed generation capacity of ER as on Aug'24 is about 36GW which constitute capacity from fossil sources (81% share) & balance (19% share) from Non-fossil sources comprising of renewable generation capacity including hydro.

Eastern Region is connected to all other regions through 765kV & 400kV high-capacity corridors along with HVDC Back to Back/ HVDC Bipole lines. The thermal generating stations of ER are predominantly located in Bihar, Jharkhand and Odisha whereas hydro generation are concentrated primarily in Sikkim. Eastern region is also connected to other countries such as Nepal, Bhutan and Bangladesh through high-capacity AC and HVDC links.

To meet the growing demand, Eastern region is continuously progressing in generation capacity addition majorly through thermal and hydro generation sources. The peak demand of Eastern Region for 2029-30 timeframe is expected to increase to about 45.7 GW. In addition to above, the demand of about 1.4GW corresponding to bulk consumer / distribution licencees is expected to be added to the grid by 2029-30. As per the inputs received from various stakeholders, total installed capacity of Eastern Region for 2029-30 is expected to be about 70 GW (including 3.3GW in Nepal and 4.5GW in Bhutan).

Various transmission schemes such as transmission system for evacuation of new generation of DVC viz. establishment of Bishnupur 400kV (ISTS) switching station & Bishnupur (ISTS) – Medinipur (POWERGRID) 400kV D/c (Quad) line, augmentation of ICT at Pandiabili, Reconductoring of transmission lines i.e. Farakka – Kahalgaon 400kV D/c & Meramunduli – Talcher 400kV D/c lines for strengthening of the grid network have been evolved in the Consultation Meeting for Evolution of Transmission System in Eastern Region (CMETS-ER) from Feb/Mar'24 to July'24. In this Rolling Plan, 3 nos. of transmission schemes of about 140 ckm of transmission line, 330ckm of reconductoring of and 500 MVA of transformation capacity have been formulated at an estimated cost of about Rs. 812 Cr. These schemes either have been approved or are under various stages of approval. Further, new network expansions in Eastern Region are being taken up on a continuous basis and the mitigation measures identified would be taken up for detailed analysis in the subsequent rolling plan.

Thus, cumulatively by 2029-30, transmission schemes comprising of 3550 ckm of transmission lines and transformation capacity of 9250 MVA at estimated cost of Rs 23,260 Cr. is expected to be added in the grid.

North Eastern Region (NER)

The total installed generation capacity of NER as on Aug'24 is about 7.8GW which constitute capacity from fossil sources (67% share) & balance (33% share) from Non-fossil sources comprising of renewable generation capacity including hydro.

North Eastern Region is connected to Eastern Region and North Region though 400kV high-capacity corridors along with multi-terminal HVDC. The thermal generating stations of Northern Eastern Region are located in Assam, gas generations are situated in Assam and Tripura whereas hydro generation is concentrated primarily in Arunachal, Manipur & Meghalaya.

To meet the growing demand, NER is continuously progressing in generation capacity addition majorly through hydro generation sources. The peak demand of North Eastern Region for 2029-30 timeframe is expected to increase to about 5.8 GW. As per the inputs received from various stakeholders, total installed capacity of Northern Eastern Region for 2029-30 is expected to be about 8.2 GW.

Various transmission schemes viz. 2nd circuit stringing of Pasighat-Roing-Tezu-Namsai corridor, ICT augmentation at Namsai, Bus Reactors at Balipara & Biswanath Chariali, installation of VSR at Misa and reconductoring of ISTS portion of Dimapur (POWERGRID) – Dimapur (Nagaland) 132kV (2nd ckt) & Dimapur (POWERGRID) – Kohima (Nagaland) 132kV lines have been approved in the Consultation Meeting for Evolution of Transmission System in North Eastern Region (CMETS-NER) from Feb/Mar'24 to July'24. In this Rolling Plan, 5 nos. of transmission schemes of about 272 ckm of transmission lines and reconductoring of 0.7 ckm of transmission lines and 50MVA transformation capacity have been formulated at an estimated cost of Rs. 211 Cr. These schemes have either been approved or are under various stages of approval.

Thus, cumulatively by 2029-30, transmission schemes comprising of 2,537 ckm of transmission lines and transformation capacity of 2,090 MVA at estimated cost of Rs 6,224 Cr. is expected to be added in the grid.

Further, evacuation of power from future hydro projects primarily in Arunachal Pradesh would be planned after firm commission schedule and significant progress in the hydro generation projects. New network expansion schemes in North Eastern Region are being taken up on a continuous basis and the mitigation measures identified would be taken up for detailed analysis in the subsequent rolling plan.

Cross Border Interconnections (CB)

The existing cross-border interconnections facilitate power transfer of about 4874MW (2311MW: Bhutan, 1160MW: Bangladesh, 1400MW: Nepal and 3MW: Myanmar) with the neighbouring countries. With the commissioning of under-construction cross-border interconnections which are expected in 2-3 years, the power transfer would enhance by about 4120MW resulting in total of about 8994MW (4531MW: Bhutan, 1160MW: Bangladesh, 3300MW: Nepal and 3MW: Myanmar).

