

## **Stakeholders Comments on ISTS schemes evolved from Feb/Mar'24 to July'24**

**Date: 30-08-2024**

ISTS network expansion schemes to be included in Interim Rolling Plan Repot 2029-30(to be published by Sep'24) are enclosed herewith.

Stakeholders (Generators, STUs, RLDCs, SLDC & Distribution Licensees) may give their observations, if any, latest by 14.09.2024 at mail ids [chinmays@powergrid.in](mailto:chinmays@powergrid.in) and [shashankshekhar@powergrid.in](mailto:shashankshekhar@powergrid.in)

## ISTS Schemes evolved from Feb'24/Mar'24 to July'24

### Contents

<b>Contents .....</b>	<b>2</b>
<b>1. ISTS Network Expansion Scheme in Eastern Region .....</b>	<b>3</b>
1.1. Odisha.....	3
1.2. Bihar, Odisha & West Bengal.....	4
<b>2. ISTS Network Expansion Scheme in North Eastern Region .....</b>	<b>6</b>
1.3. Assam.....	6
1.4. Nagaland.....	9
1.5. Arunachal Pradesh.....	10
1.6. Assam & Arunachal Pradesh.....	12
<b>3. ISTS Network Expansion Scheme in Western Region .....</b>	<b>15</b>
3.1 Gujarat .....	15
3.2 Maharashtra .....	35
3.3 Madhya Pradesh.....	37
3.4 Chhattisgarh .....	44
<b>4. ISTS Network Expansion Scheme in Northern Region.....</b>	<b>48</b>
4.1 Rajasthan.....	48
4.2 Punjab.....	73
4.3 Jammu & Kashmir.....	76
<b>5. ISTS Network Expansion Scheme in Southern Region.....</b>	<b>81</b>
5.1 Andhra Pradesh.....	81
5.2 Karnataka .....	93
5.3 Tamil Nadu.....	96

## ISTS Schemes evolved from Feb'24/Mar'24 to July'24

### 1. ISTS Network Expansion Scheme in Eastern Region

Various transmission schemes have been discussed/finalized in the Consultative Meeting for Evolution of Transmission System of Eastern Region (CMETS-ER) from Feb 2024 to July 2024. The details of the schemes are summarized below:

#### 1.1. Odisha

##### (a) ERES-42 – 3<sup>rd</sup> ICT at Pandiabili

Presently, 400/220kV Pandiabili (POWERGRID) S/s is having the transformation capacity of 2x500MVA. The maximum loading has crossed 500MW. Further, with upcoming Pratapsan – Cuttack 220kV line and Pandiabili (POWERGRID) – Samangara 220kV line, the existing transformers would breach the N-1 criteria. Accordingly, there is requirement of new 1x500MVA, 400/220kV (3rd) ICT at Pandiabili (POWERGRID) S/s.

Presently, 1 no. 400kV spare GIS bay is being implemented at Pandiabili GIS S/s (under approved ERBS-I scheme) with completion schedule of 30-09-2024. The said spare bay is planned to be used for installation of 3rd ICT. The same timeline viz. 30-09-2024 is planned for augmentation of transformation capacity at Pandiabili S/s so as to match availability of ICT and associate bay. For installation of 3rd ICT, there is requirement of GIB duct of 250m (1-Ph) and 100m (1-Ph) at 400kV and 220kV levels respectively.

This scheme has been agreed in the 31<sup>st</sup> CMETS-ER held on 30-05-2024.

Sl. No.	Scope of the Transmission Scheme	Capacity (MVA) / Line length (km)/ Nos.
1.	Installation of new 1x500MVA, 400/220kV (3rd) ICT at Pandiabili (POWERGRID) S/s along with associated bay at 220kV level [using the bay no. 413 at 400kV level, which is already under implementation under ERBS-I scheme].	<ul style="list-style-type: none"> <li>• 500MVA, 400/220kV ICT: 1 no.</li> <li>• 220kV GIS ICT bay: 1 no.</li> <li>• 400kV GIS duct: 250m approx.(1-Ph)</li> <li>• 220kV GIS duct: 100m approx.(1-Ph)</li> </ul>
<p><i>Note: POWERGRID is inter alia implementing a full diameter (413-414-415) under ERBS-I scheme for termination of one circuit of Talcher-III – Pandiabili (POWERGRID) 400kV D/c line in bay no. 415. The other bay of the diameter viz. 413 is planned to be used for termination of the 3<sup>rd</sup> 400/220kV ICT.</i></p>		

**Implementation time-frame:** 30-09-2026

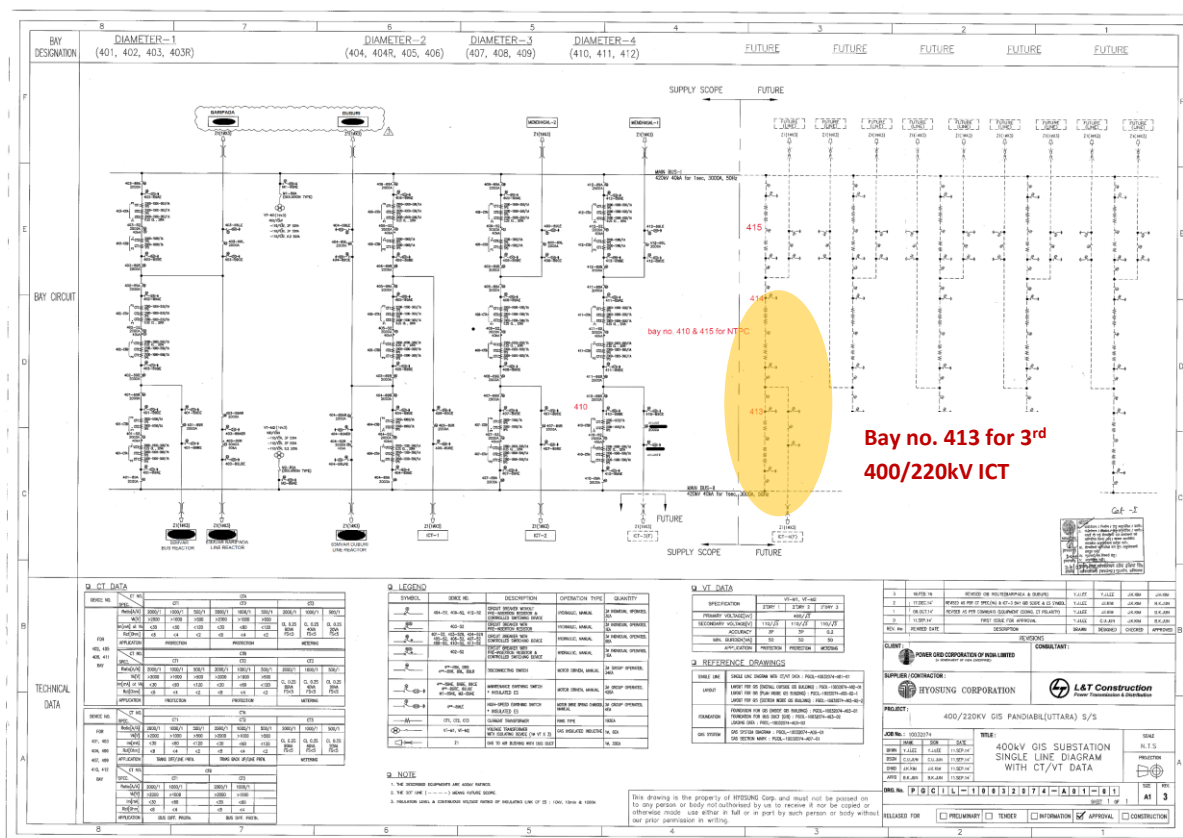

## 1.2. Bihar, Odisha & West Bengal

### (a) ERES-43 – Reconductoring (Farakka, Kahalgaon, Talcher & Meramunduli)

ER predominantly has thermal generations. During the peak solar hours in neighbouring regions of ER, backing down of thermal generations takes place in ER. Under such scenario, constraints are being observed on Kahalgaon (NTPC) – Farakka (NTPC) 400kV D/c line and Talcher (NTPC) – Meramundali (OPTCL) 400kV D/c line (one circuit LILOed at Angul and subsequently bypassed) under N-1.

The Kahalgaon – Farakka 400kV D/c line with thermal rating of 850MVA/ckt. During the peak solar hours loading of 400kV Kahalgaon – Farakka D/c remains above the N-1 security limit. During the backing down of generators of both ends the power flow through this line is above 650MW per circuit.

On the other side Due to frequent outage of HVDC Talcher – Kolar on forced outages/ tripping/ maintenance activities during the peak solar hours constraints in 400 kV Talcher – Meramundali lines. One circuit of Talcher – Meramundali 400kV D/c line was LILOed at Angul in the HCPTC-I project which was subsequently bypassed from Angul switchyard. Due to different length of both circuit uneven power flows through in both circuits. The power flow on the long line is about 300MW and shorter line is about 500MW. On many occasions, to facilitate any planned shutdown in the complex (N-1), generation back down at Talcher I & II, which are cheap pit-head plants, is required to be done to limit the power flow in the Talcher – Meramundali lines.

In view of above, to eliminate these constraints reconductoring of 400kV Kahalgaon – Farakka D/c line & 400 kV Talcher – Meramundali lines with HTLS conductor of 1228A ampacity was discussed and agreed in the 31<sup>st</sup> CMETS-ER held on 30-05-2024. Reconductoring of these lines with upgradation of associated 400kV bay equipments at both ends of lines are being taken up under this scheme. As urgent

requirement of the scheme and that the line lengths are less, the timeframe of the scheme may be considered as 18 months with best effort basis schedule as 15 months

Sl. No.	Scope of the Transmission Scheme	Capacity (MVA) / Line length (km)/ Nos.
1.	Reconductoring of Kahalgaon (NTPC) – Farakka (NTPC) 400kV D/c (Twin Moose) line with Twin HTLS conductor (with ampacity of single HTLS as 1228A)	190ckm
2.	Reconductoring of Talcher (NTPC) – Meramundali (OPTCL) 400kV D/c (Twin Moose) line (one circuit via Angul and bypassed at Angul) with Twin HTLS conductor (with ampacity of single HTLS as 1228A)	140ckm
3.	Upgradation of associated 400kV bay equipment at Kahalgaon (NTPC)	Associated bay equipment with line capacity 3150A (as per standard equipment rating).
4.	Upgradation of associated 400kV bay equipment at Farakka (NTPC)	Associated bay equipment with line capacity 3150A (as per standard equipment rating).
5.	Upgradation of associated 400kV bay equipment at Talcher (NTPC)	Associated bay equipment with line capacity 3150A (as per standard equipment rating).
6.	Upgradation of associated 400kV bay equipment at Meramundali (OPTCL)	Associated bay equipment with line capacity 3150A (as per standard equipment rating).

**Note:**

- (a) NTPC and OPTCL to provide unconditional access to the ISTS licensee for upgradation of identified bay equipment at their respective substation / generation switchyard. The equipment released after replacement shall be handed over to NTPC and OPTCL on as is where is basis by the ISTS licensee.
- (b) NTPC has already awarded R&M works for diameter 19-20-21 and 22-23-24 for some bay equipments at Farakka switchyard. Further, at Kahalgaon switchyard, R&M for some equipments of diameter 31-32-33 has also been awarded. ISTS licensee needs to coordinate with NTPC for replacement of balance equipments at Farakka and Kahalgaon switchyards as identified from Annexure-VII and Annexure-VIII (comprising of SLD and bay equipment details) respectively of the minutes of the 31<sup>st</sup> CMETS-ER.
- (c) ISTS licensee needs to coordinate with NTPC and OPTCL for replacement of equipments at Talcher switchyard and Meramundali S/s respectively as identified from Annexure-V and Annexure-VI respectively (comprising of SLD and bay equipment details) of the minutes of the 31<sup>st</sup> CMETS-ER.

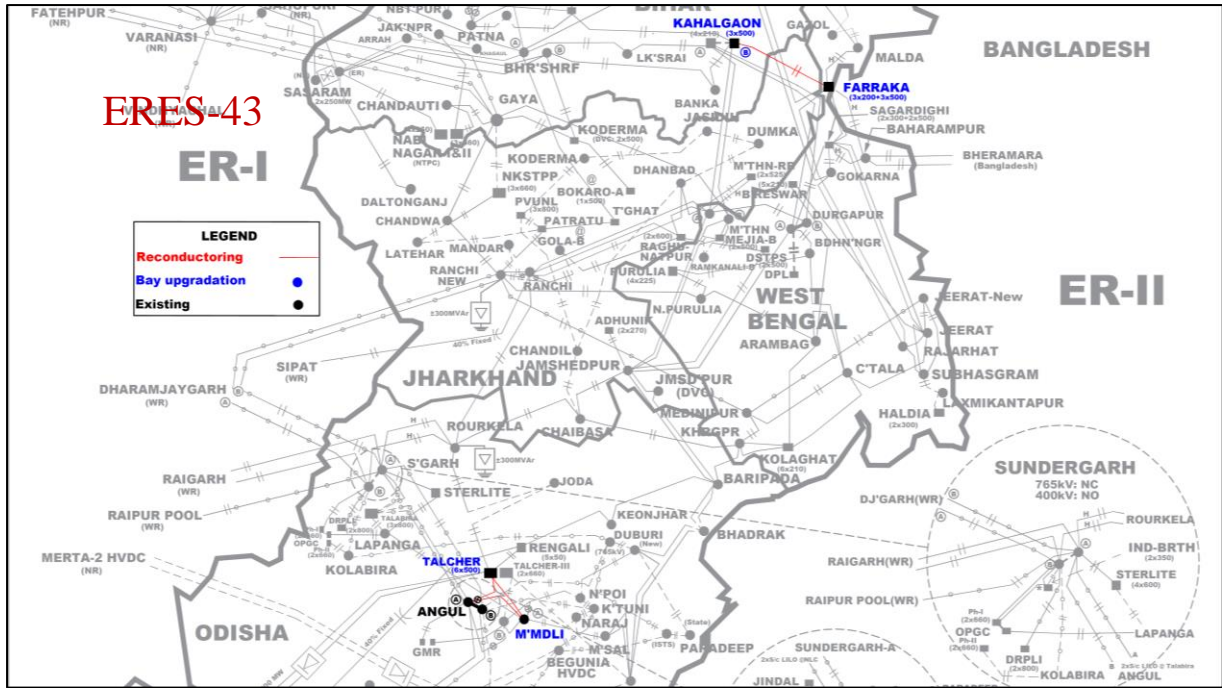

## 2. ISTS Network Expansion Scheme in North Eastern Region

Various transmission schemes have been discussed/finalized in the Consultative Meeting for Evolution of Transmission System of Eastern Region (CMETS-NER) from Feb 2024 to July 2024. The details of the schemes are summarized below:

### 1.3. Assam

#### (a) NERES-XXVI (Bornagar bus reactor)

Presently, 2x50MVAR + 2x80MVAR (installed in parallel) + 1x125MVAR bus reactors are available at Bongaigaon (POWERGRID) S/s at 400kV voltage level. Out of which 50MVAR Bus Reactors - I & II were commissioned in 1987 & 1994 respectively. After serving more than 29 years, it has been observed that the reactors are continuously giving problems. For further assessment of the health, matter was referred by POWERGRID to CPRI, Bangalore for Residual Life Assessment. After reviewing all parameters, CPRI has opined for replacement of the subject bus reactor.

On annual basis at Bongaigaon 400kV bus, average of minimum voltage is about 402kV, and average bus voltage is about 409kV. Accordingly, in order to keep the bus voltage near nominal levels, the existing quantum of reactive compensation is required to be maintained. As per the study, it was observed that new reactors of 50MVAR may not be installed due to their reduced capability in changing bus voltage upon switching. Thus, a new 125MVAR bus reactor has been planned to be installed in one of the vacated bus reactor bays after decommissioning of old 2x50MVAR bus reactors. Further, as the existing 2x80MVAR bus reactors are installed in parallel, one of these 80MVAR bus reactors is planned to be installed in the other vacated bay after decommissioning of 2x50MVAR bus reactors. After decommissioning of old 2x50MVAR bus reactor and commissioning of new 1x125MVAR, there would be 2x80MVAR + 2x125MVAR bus reactors at Bongaigaon (POWERGRID) S/s and all bus reactors would be installed in separate bays.

The above proposal was agreed in the 22<sup>nd</sup> CMETS-NER held on 28-08-2023.

Sl. No.	Scope of the Transmission Scheme	Capacity (MVA) / Line length (km)/ Nos.
3.1	Decommissioning of existing 420kV, 50MVA <sub>r</sub> (bus reactor-1) and installation of new 420kV, 125MVA <sub>r</sub> bus reactor in its place along with replacement of associated main and tie bay equipment at Balipara (POWERGRID) S/s	<ul style="list-style-type: none"> <li>• 420kV, 1x125MVA<sub>r</sub> Bus Reactor: 1 no.</li> <li>• Replacement of 400kV main &amp; tie bay equipment of bus reactor diameter</li> </ul>

**Implementation time-frame:** 14-12-2025

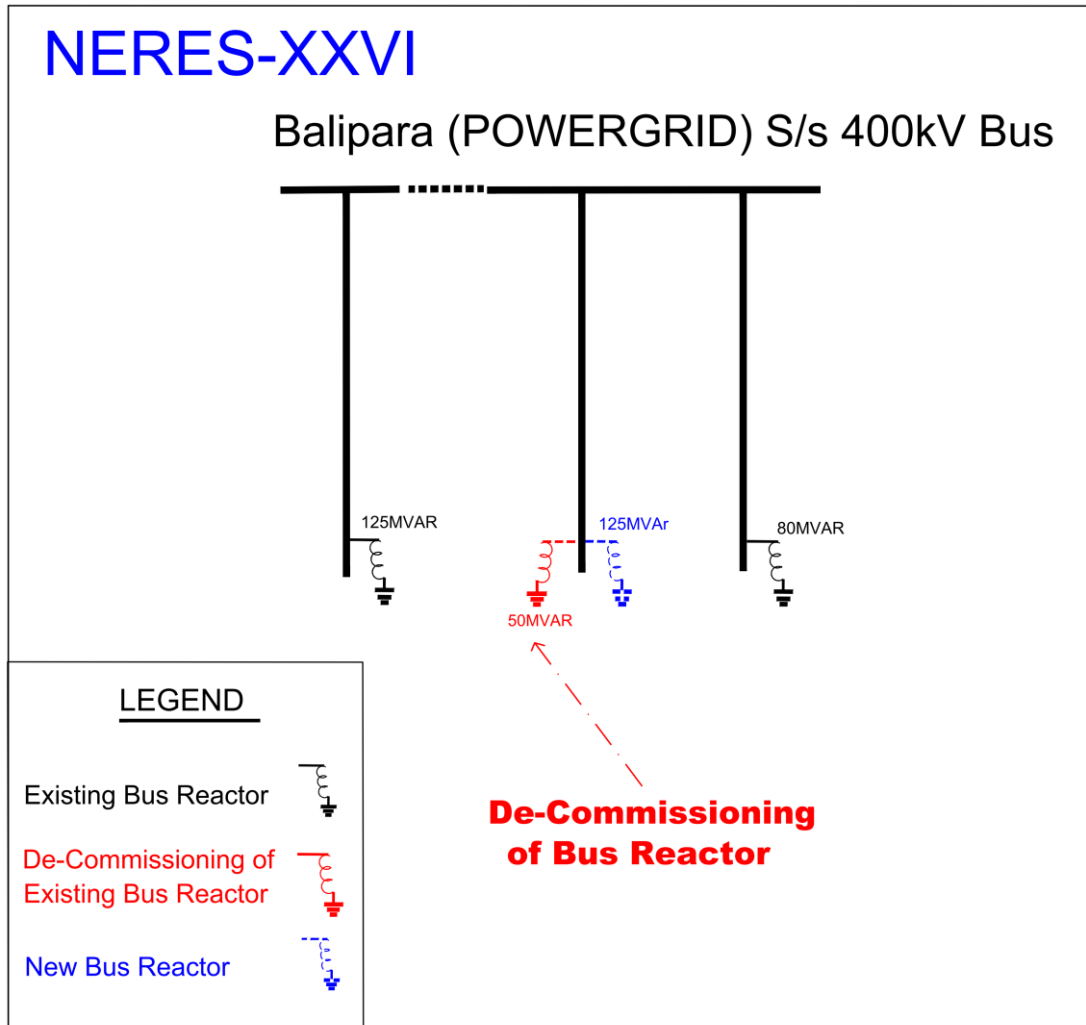

**(b) NERES-XXVIII (VSR at Misa)**

Presently, 1x50MVA<sub>r</sub> + 1x80MVA<sub>r</sub>, 420kV Bus reactors are installed at Misa (POWERGRID) 400/220kV S/s. Additionally, 36kV, 4x25MVA<sub>r</sub> bus reactors are also installed in tertiary of 400/220/33kV ICT at Misa (POWERGRID) S/s.

These tertiary reactors are almost 24 to 28 years old and as informed by POWERGRID, there is no support from OEM. Due to ageing, the conditions of these tertiary reactors have deteriorated, and heavy oil leakages are frequently reported even after gasket replacements. In recent time, it is observed that even with the 4x25MVA<sub>r</sub> tertiary bus reactors, maximum voltage at 400kV bus is in the range of 415kV to 418kV and 25% of time it is above nominal voltage level. After

decommissioning of tertiary reactors, the voltage at Misa S/s will increase further. Accordingly, it was suggested that with decommissioning of tertiary reactors, additional bus reactor may be planned at Misa S/s.

Accordingly, decommissioning of existing 36kV, 4x25MVA bus reactors installed in tertiary of 400/220/33kV ICT(s) at Misa S/s and installation of new 420kV, 1x125MVA bus reactors with associated GIS bay at Misa (POWERGRID) S/s was discussed and agreed in the 29<sup>th</sup> CMETS-NER held on 28-03-2024. In view of space constraint, bay for bus reactor is planned in GIS with double bus scheme with two circuit breakers.

Sl. No.	Scope of the Transmission Scheme	Capacity (MVA) / Line length (km)/ Nos.
1.	Installation of new 420 kV, 1x125 MVA bus reactor along with associated GIS bay at Misa (POWERGRID) S/s	<ul style="list-style-type: none"> <li>• 420 kV, 1x125 MVA Bus Reactor: 1 No.</li> <li>• 400 kV GIS bus reactor bay: 1 No. [ @with two circuit breakers]</li> <li>• 400kV GIB: 1000m (approximate)</li> </ul>

**Note:** *®In view of space constraints for GIS extension and space constraint towards usage of other bay of one and half breaker scheme, bus reactor is planned to be installed in double bus scheme with two circuit breakers*

**Implementation time-frame:** 14-03-2026

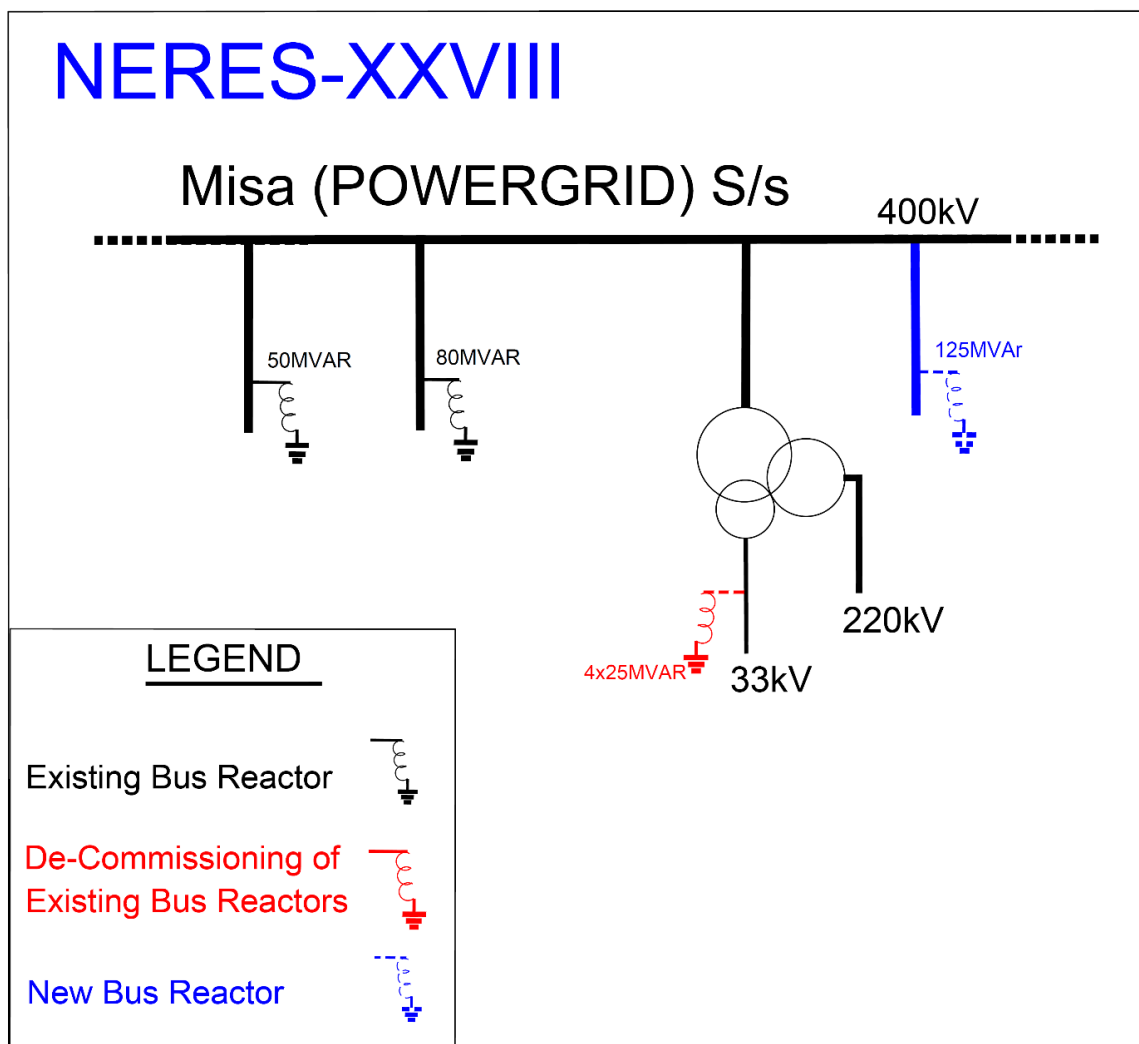

#### 1.4. Nagaland

##### (a) NERES-XXVII (Reconductoring Dimapur, Kohima)

Dimapur (DoP, Nagaland) – Kohima (DoP, Nagaland) 132kV S/c line of DoP, Nagaland was LILoed by POWERGRID under ISTS at Dimapur (POWERGRID) S/s, resulting in formation of Dimapur (POWERGRID) – Dimapur (Nagaland) ckt-2 and Dimapur (POWERGRID) – Kohima (DoP, Nagaland) 132kV S/c lines, which became partly owned by DoP, Nagaland and partly owned by POWERGRID.

The conductor of Dimapur (DoP, Nagaland) – Dimapur (POWERGRID) and Dimapur (POWERGRID) – Kohima (DoP, Nagaland) 132kV lines are very old (commissioned around 1970) and their thermal rating is of the order of 40MVA only (degraded). Upon outages of Kohima (DoP, Nagaland) – Karong (MSPCL) & Doyang – Wokha 132kV S/c lines, high loadings are observed in Nagaland intra-state system. Dimapur (DoP, Nagaland) is fed radially from ISTS substation through two single circuit lines and if one circuit of Dimapur (POWERGRID) – Dimapur (DoP, Nagaland) is out, the other circuit would also trip on overloading. The demand at Dimapur is expected to reach 130MW in next 2 years and for reliable power supply reconductoring of Dimapur (POWERGRID) – Dimapur (Nagaland) ckt-1 & ckt-2 is required. Ckt-1 is owned by DoP, Nagaland and ckt-2 is jointly owned by DoP, Nagaland and POWERGRID.

In view of the above, to strengthen the power supply situation in major cities of Nagaland viz. Kohima and Dimapur, reconductoring of Dimapur (POWERGRID) – Dimapur (Nagaland) ckt-1 & ckt-2 and Dimapur (POWERGRID) – Kohima (DoP, Nagaland) 132kV S/c lines with HTLS conductor of 800A ampacity was discussed and agreed in the 29<sup>th</sup> CMETS-NER held on 28-03-2024. Reconductoring of ISTS portion of these lines are being taken up under this scheme. DoP, Nagaland shall reconductor their portion of lines in matching time-frame.

Sl. No.	Scope of the Transmission Scheme	Capacity (MVA) / Line length (km)/ Nos.
1.	Reconductoring of ISTS portion of Dimapur (POWERGRID) – Dimapur (DoP, Nagaland) 132kV (ckt-2) ACSR Panther S/c line with Single HTLS conductor of 800A	0.335km
2.	Reconductoring of ISTS portion of Dimapur (POWERGRID) – Kohima (DoP, Nagaland) 132kV ACSR Panther S/c line with Single HTLS conductor of 800A	0.335km

**Implementation time-frame:** 14-09-2025

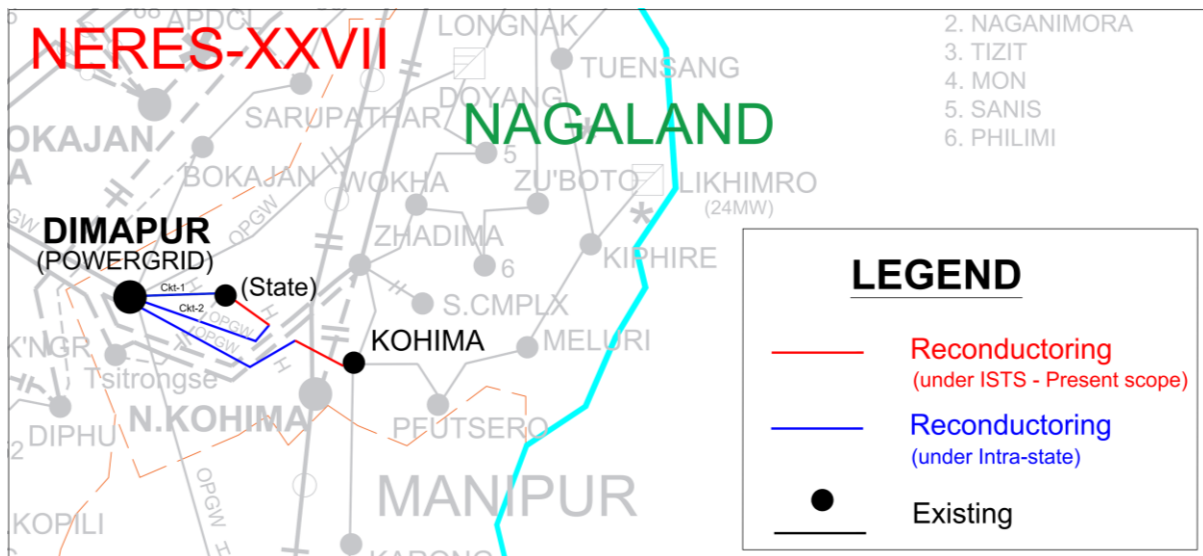

### 1.5. Arunachal Pradesh

**(a) NERES-XXIII (Reconductoring of Pasighat – Roing – Tezu – Namsai Corridor)**

Pasighat (Arunachal Pradesh) – Roing (POWERGRID) – Tezu (POWERGRID) – Namsai (POWERGRID) 132kV S/c on D/c corridor is owned by POWERGRID. Pasighat (Arunachal Pradesh) S/s is of DoP, Arunachal Pradesh and Roing, Tezu & Namsai substations are of POWERGRID.

DoP, Arunachal Pradesh informed that additional industrial demand of about 100MW (1st - 35MW and 2nd - 65MW) is expected at Niglok (Arunachal Pradesh) S/s. Niglok (Arunachal Pradesh) is connected to Napit/New Pasighat and Likbali substations of DoP, Arunachal Pradesh. POWERGRID, NERLDC and DoP, Arunachal Pradesh had mentioned that owing to hilly and difficult terrain conditions in Arunachal Pradesh, 2nd circuit stringing of Roing – Tezu – Namsai 132kV S/c on D/c line also needs

to be taken up for reliable power supply in the area. Moreover, various new HEPs are coming up in Arunachal Pradesh in these areas which require construction power as well. Thus, keeping in view upcoming industrial demand, regular demand growth in eastern Arunachal Pradesh, and to improve reliability of 132kV system (predominantly S/c), it was agreed to take up 2nd circuit stringing of various intra-state [Gerukamukh – Likabali – Niglok – Pasighat (New)] and ISTS lines [Pasighat (Arunachal Pradesh) – Roing (POWERGRID) – Tezu (POWERGRID) – Namsai (POWERGRID)].

The ISTS portion of the scope under subject scheme was finalized after detailed consultation in the 29th CMETS-NER held on 28-03-2024.

Sl. No.	Scope of the Transmission Scheme	Capacity/km
(a)	Stringing of 2 <sup>nd</sup> circuit of Pasighat (Arunachal Pradesh) – Roing (POWERGRID) 132kV S/c on D/c line with ACSR Panther conductor commensurate with rating and maximum operating temperature of 1 <sup>st</sup> circuit	103km
(b)	Stringing of 2 <sup>nd</sup> circuit of Roing (POWERGRID) – Tezu (POWERGRID) 132kV S/c on D/c line with ACSR Panther conductor commensurate with rating and maximum operating temperature of 1 <sup>st</sup> circuit	73km
(c)	Stringing of 2 <sup>nd</sup> circuit of Tezu (POWERGRID) – Namsai (POWERGRID) 132kV S/c on D/c line with ACSR Panther conductor commensurate with rating and maximum operating temperature of 1 <sup>st</sup> circuit	95.24km
(d)	Extension at Pasighat (DoP, Arunachal Pradesh) <sup>@</sup> : 1 no. 132kV AIS line bay for termination of 2 <sup>nd</sup> circuit of Pasighat (Arunachal Pradesh) – Roing (POWERGRID) 132kV D/c line	132kV AIS line bay: 1 no.
(e)	Extension at Roing (POWERGRID) S/s: 2 no. 132kV AIS line bay for termination of 2 <sup>nd</sup> circuit of Pasighat (Arunachal Pradesh) – Roing (POWERGRID) 132kV D/c line and 2 <sup>nd</sup> circuit of Roing (POWERGRID) – Tezu (POWERGRID) 132kV D/c line	132kV AIS line bay: 2 no.
(f)	Extension at Tezu (POWERGRID) S/s: 2 no. 132kV AIS line bay for termination of 2 <sup>nd</sup> circuit of Roing (POWERGRID) – Tezu (POWERGRID) 132kV D/c line and 2 <sup>nd</sup> circuit of Tezu (POWERGRID) – Namsai (POWERGRID) 132kV D/c line	132kV AIS line bay: 2 no.
(g)	Extension at Namsai (POWERGRID) S/s: 1 no. 132kV AIS line bay for termination of 2 <sup>nd</sup> circuit of Tezu (POWERGRID) – Namsai (POWERGRID) 132kV D/c line	132kV AIS line bay: 1 no.

**Implementation time-frame:** 14-12-2026

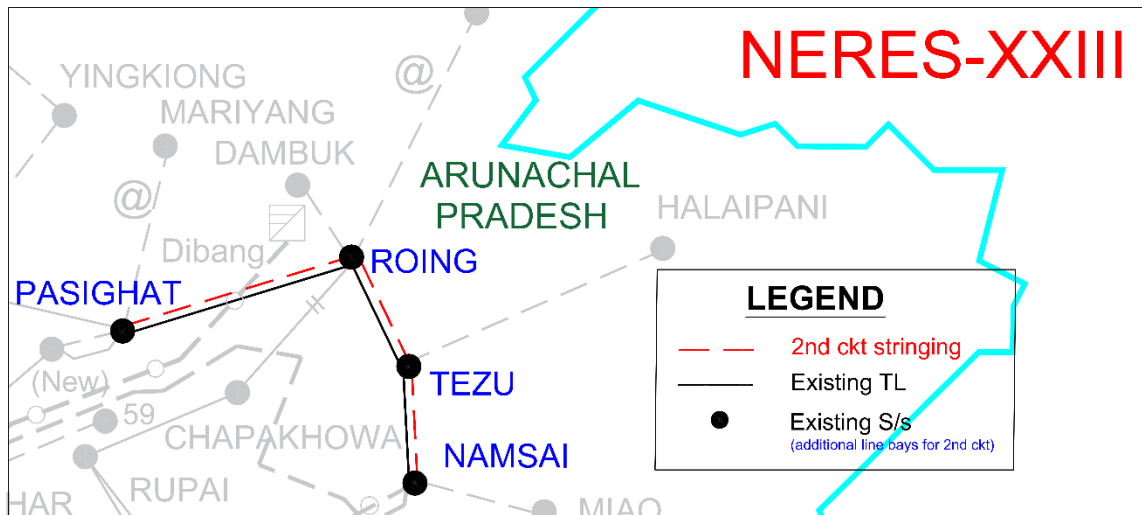

### 1.6. Assam & Arunachal Pradesh

(a) NERES-XXIX (Namsai ICT & Biswanath Chariali Reactor)

132/33kV Namsai S/s is owned by POWERGRID. At present there are 2x15MVA ICT at this substation. DoP Arunachal Pradesh mentioned that presently the total load at Namsai area is about 13MW out of which 9MW is met through Namsai (POWERGRID) S/s and 4MW is met through Rupai – Namsai 33kV old line. The load at Namsai is expected to reach to about 17MW by Mar 2027. Rupai – Namsai 33kV line was implemented long back to supply power to Namsai area when 132kV was not available. Now, Namsai is one of the fastest growing load centres in Arunachal Pradesh due to improvement in road and other infrastructures. Accordingly, for reliable and power supply 4MW load is also fed from ISTS S/s and the old 33kV line is made to be defunct. Thus, there shall be drawl requirement of about 17MW in next few years at Namsai (POWERGRID) S/s, which would not be N-1 compliant. Further, as per CEA’s “Standard Specifications and Technical Parameters for Transformers and Reactors (66 kV & above Voltage Class)” published in April 2021, the minimum standard rating of 132/33kV, 3-phase ICT is of 31.5MVA. Presently there are two different rating of 132/33kV ICTs in NER viz. 1-phase 5MVA and 3-phase 50MVA. To meet the contingency requirement in case of failure of ICT, spare 50MVA ICT is also available in the region and presently kept at Nirjuli S/s. Accordingly, a new 1x50MVA ICT was proposed and agreed in 33<sup>rd</sup> CMETS-NER held on 26-07-2024.

During winter season, monopole operation in reverse direction of Agra to BNC HVDC link is being carried out with metallic return mode through the conductor of the other pole. Therefore, voltage on metallic return conductor has been negligible which results of theft of line materials like spacer, corona ring etc. Theft of hundreds of spacer-dampers has been experienced in the past which leads to damage of conductor fittings and accessories and chance of conductor snapping increases. Accordingly, a solution was proposed to operate in Bipole mode during reverse power flow (Agra to BNC) during winter season.

Presently at BNC there are 4 no. of 63MVAR switchable line reactor connected in BNC – Lower Subansiri 400kV 2xD/c line which are being used as Bus Reactor as generation is not commissioned. After studies it was observed that, During charging of 1<sup>st</sup> circuit of Biswanath Chariali (POWERGRID) – Lower Subansiri 2xD/c line (along with 63MVAR switchable line reactor at BNC end), about 3.5kV voltage rise is observed at BNC end and upon charging of all four circuits from BNC to LS, total about

14-15kV rise is observed at BNC end. Subsequently, upon charging of 1x80MVA Bus reactor at Lower Subansiri end, voltage drop by about 4kV at BNC end and with 2x80MVA Bus reactor voltage drop by about 8kV at BNC end was observed. Further, with new 1x125MVA Bus reactor at BNC, the voltage drop is observed to be about 6kV at BNC end. So overall voltage at BNC end comes back to its original voltage level with additional 125MVA bus reactor. According due to operational requirements an additional 1x125MVA, 420kV bus reactor at BNC (POWERGRID) S/s was agreed in the 31<sup>st</sup> CMETS-NER held on 29-05-2024.

Sl. No.	Scope of the Transmission Scheme	Capacity (MVA) / Line length (km) / Nos.
(a)	Installation of new 1x50MVA, 132/33kV (3 <sup>rd</sup> ) ICT at Namsai (POWERGRID) S/s along with associated bays.	<ul style="list-style-type: none"> <li>• 50MVA, 132/33kV ICT: 1 no.</li> <li>• 132kV ICT bays: 1 no.</li> <li>• 33kV ICT bays: 1 no.</li> </ul>
(b)	Installation of new 420kV, 125MVA Bus Reactor at Biswanath Chariali (POWERGRID) S/s along with associated bays.	<ul style="list-style-type: none"> <li>• 420kV, 125MVA Bus Reactor: 1 no.</li> <li>• 400kV reactor bay: 1 no. (main and tie bay in AIS)</li> </ul>

**Implementation time-frame:** 18 months from allocation

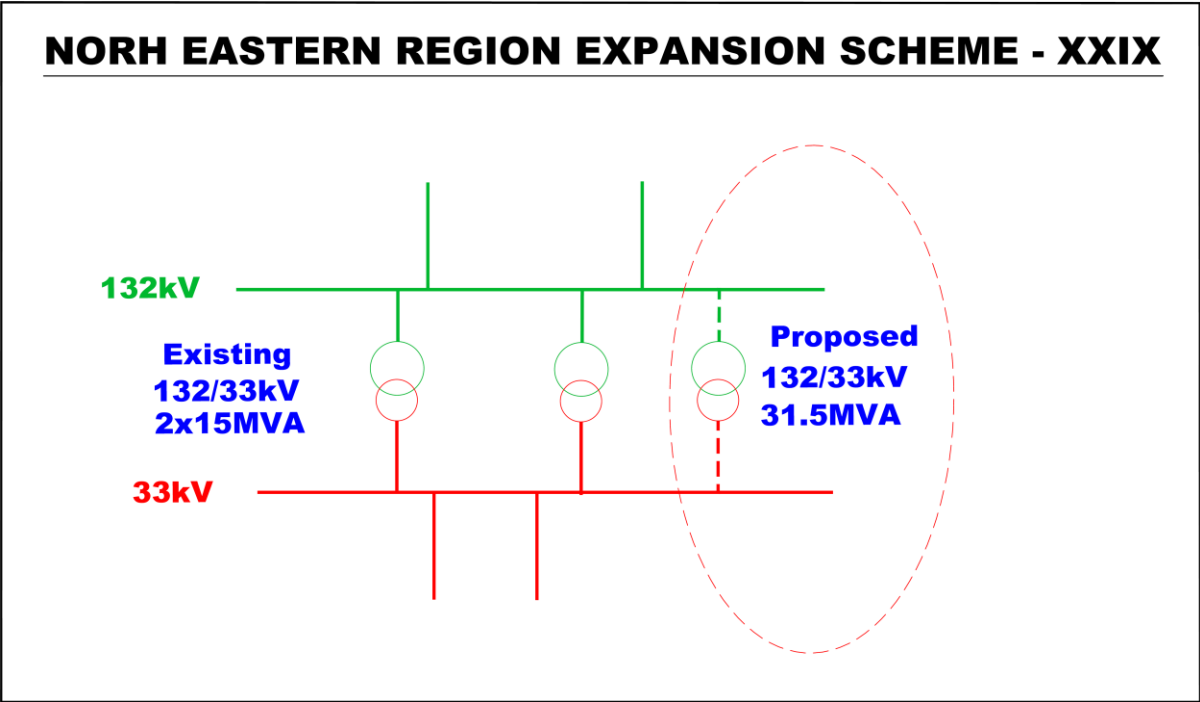
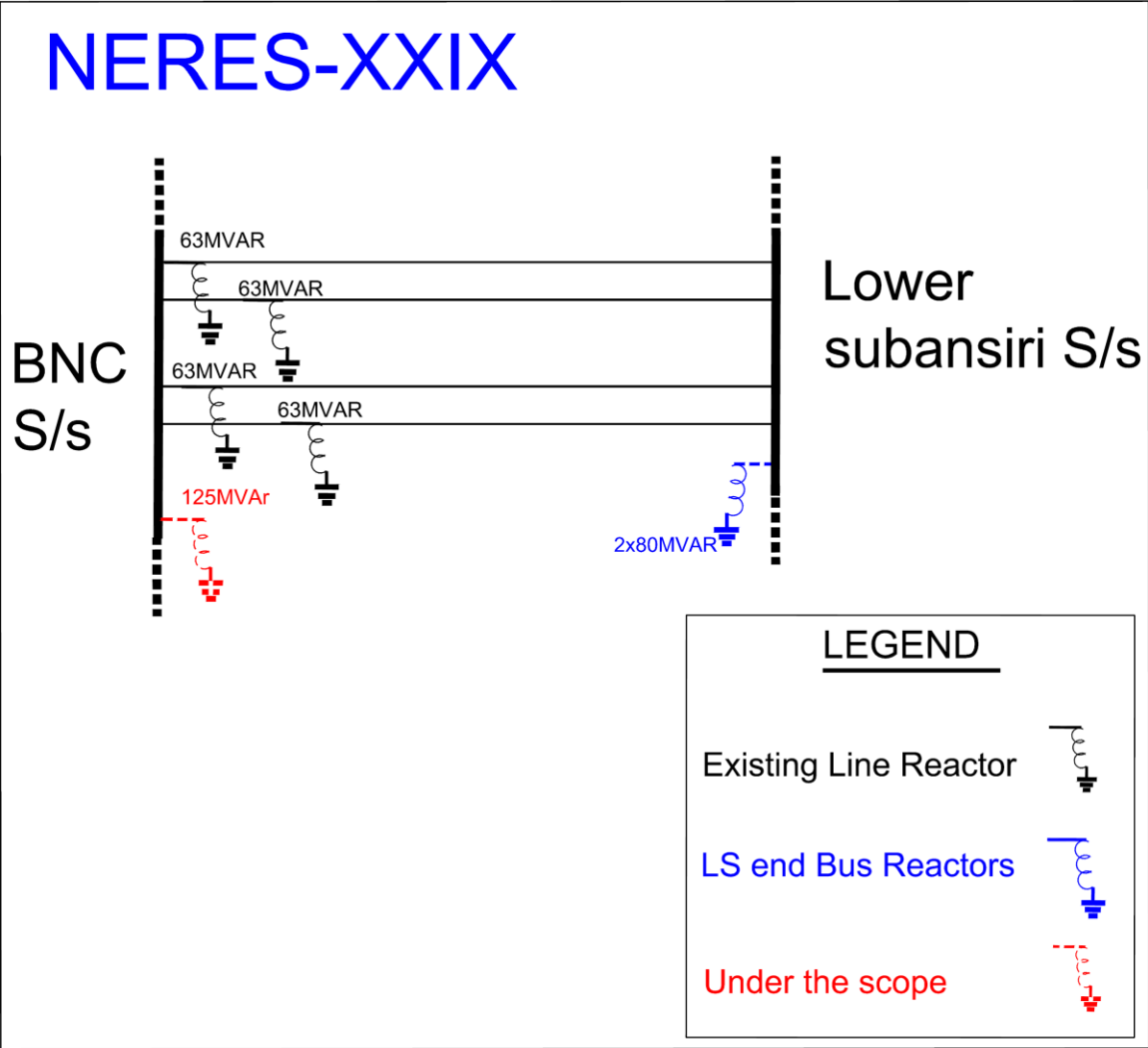

### 3. ISTS Network Expansion Scheme in Western Region

Various transmission schemes have been discussed/finalized in the Consultative Meeting for Evolution of Transmission System of Western Region (CMETS-WR) from Feb 2024 to July 2024. The details of the schemes are summarized below:

#### 3.1 Gujarat

##### (a) Augmentation of transformation capacity at KPS1 (GIS) & KPS2 (GIS) & KPS3 (GIS) (Khavda Phase-V Part-B)

###### **KPS1 Augmentation:**

KPS1 (GIS) S/s with 3x1500MVA 765/400kV ICTs on Sec-I is already commissioned by M/s Adani Transmission Limited. Augmentation of transformation capacity by 1x1500MVA 765/400kV ICT (4<sup>th</sup>) on Sec-I is also being implemented by M/s ATL under RTM under Khavda Ph-IV Part-E1 scheme. Further, Sec-II of KPS1 is being established by M/s Megha Engineering & Infrastructures Limited with SCOD of Jan-25 with 4x1500MVA 765/400kV ICTs.

Further, applications for Connectivity for additional 810MW were received from M/s Adani Green Energy Ltd. Augmentation of transformation capacity is required to enable the injection of 810MW power at KPS1 maintaining N-1 criteria compliance. The scheme was discussed and approved in the 21<sup>st</sup> NCT meeting held on 06.08.2024 for implementation under TBCB route.

###### **KPS2 Augmentation:**

KPS2 S/s with 4x1500MVA, 765/400kV ICTs (2x1500 MVA on Sec-I & 2x1500 MVA on Sec-II) is under implementation by POWERGRID. 4x1500 MVA (2x1500 MVA on Sec-I & 2x1500 MVA on Sec-II) Addl. ICTs are also being implemented by POWERGRID (under TBCB) under Khavda Ph-IV Part-E2 scheme.

However, to enable the onward dispersal of power from KPS2 maintaining the N-1 criteria compliance, augmentation of transformation capacity by 1x1500MVA, 765/400kV ICT(9<sup>th</sup>) is proposed. The scheme was discussed and approved in the 21<sup>st</sup> NCT meeting held on 06.08.2024 for implementation under TBCB route.

###### **The detailed scope of work for the above schemes is tabulated as below:**

Sl. No.	Scope of the Transmission Scheme	Capacity /km
1.	<b><u>Khavda Ph-V Part-B1</u></b> Augmentation of transformation capacity at KPS1(GIS) by 1x1500 MVA, 765/400 kV ICT on Bus section-II (9th)	<ul style="list-style-type: none"> <li>• 1500 MVA, 765/400 kV ICT – 1 Nos.</li> <li>• 765kV ICT bay – 1 Nos. on Bus section-II</li> <li>• 400 kV ICT bay – 1 Nos. (+1 Nos. (with Sw. LR bay provision) for Dia. Completion in GIS) on Bus section-II</li> </ul>
2.	<b><u>Khavda Ph-V Part-B2</u></b> Augmentation of transformation capacity at KPS2(GIS) by 1x1500 MVA, 765/400 kV ICT on Bus section-I (9th)	<ul style="list-style-type: none"> <li>• 1500 MVA, 765/400 kV ICT – 1 Nos.</li> <li>• 765 kV ICT bay – 1 Nos. (+1 Nos. (with Sw. LR bay provision) for Dia. Completion in GIS) on Bus section-I</li> <li>• 400 kV ICT bay – 1 Nos. (+1 Nos. (with Sw. LR bay provision) for Dia. Completion in GIS) on Bus section-I</li> </ul>

**Implementation time frame:** 24 months from the date of award to implementing agency

**Estimated cost:** Rs. 466 Cr.

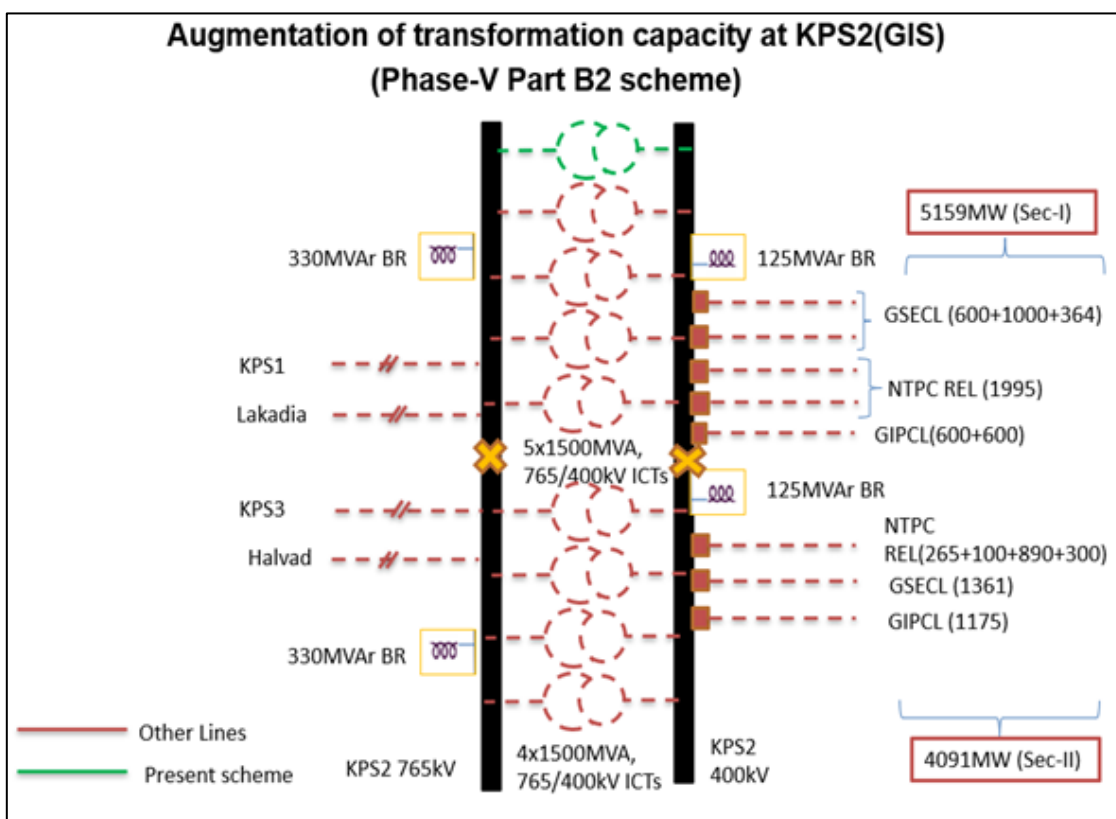
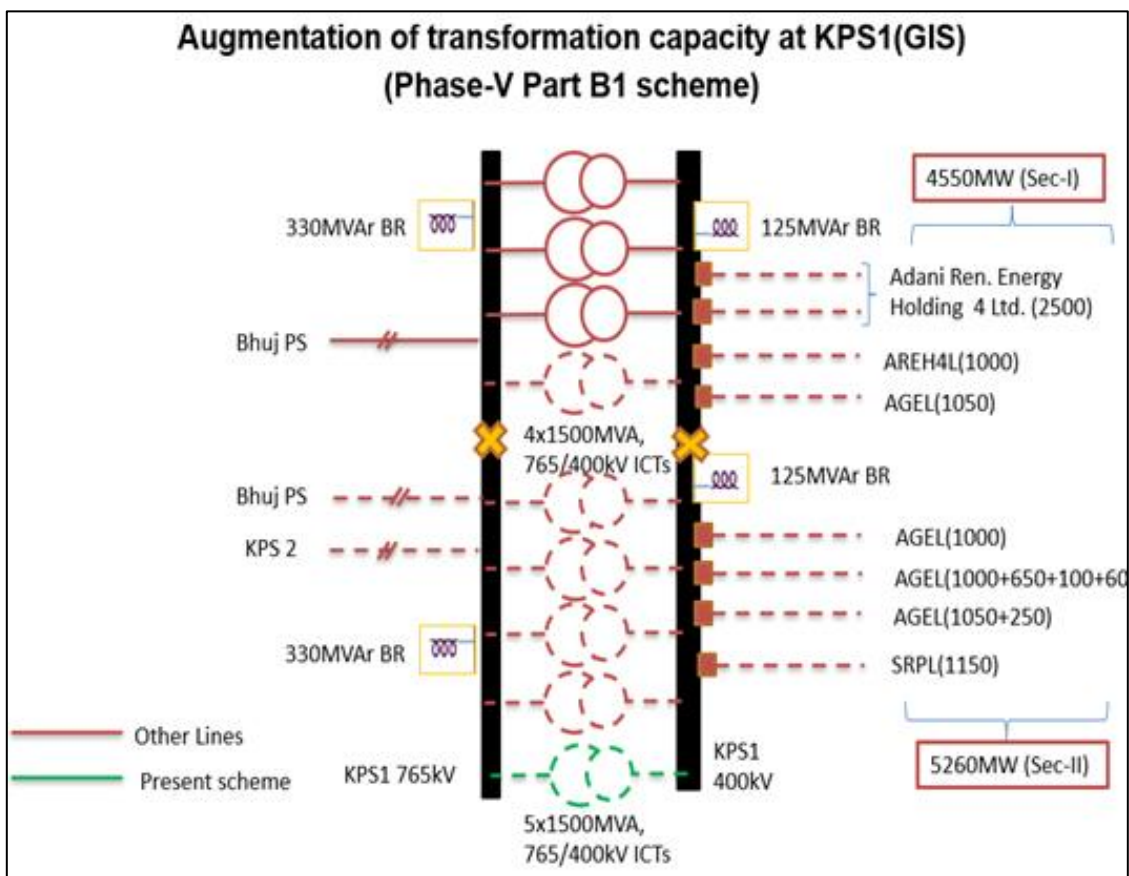

**KPS3 Augmentation:**

KPS3 S/s with 3x1500MVA, 765/400kV ICTs on Sec-I is under implementation by POWERGRID. Augmentation of transformation capacity by 1x1500MVA, 765/400kV ICT on Sec-I was also awarded to POWERGRID under RTM and is currently under implementation. Scheme for augmentation by 3x1500MVA, 765/400kV ICTs on Sec-II of KPS3 is under bidding under Khavda Ph-IV Part-A scheme.

Connectivity for 4600MW on Sec-I and 1850MW on Sec-II was granted at KPS3 against applications received so far. Further, applications for additional Connectivity for 3290MW (270MW on Sec-I & 3020MW on Sec-II) were received. Augmentation of transformation capacity by 1x1500MVA, 765/400kV ICT (8<sup>th</sup>) is required to enable the injection of additional 3290MW power from KPS3 considering the margins to be sufficient on commissioning of HVDC. The scheme was discussed and agreed for in the 31<sup>st</sup> CMETS-WR meeting held on 03.08.2024.

Sl. No.	Scope of the Transmission Scheme	Capacity /km
<b><u>Khavda Phase-V Part B3</u></b>		
1.	Augmentation of transformation capacity at KPS3(GIS) by 1x1500MVA, 765/400 kV ICT on Bus section-II (8 <sup>th</sup> )	<ul style="list-style-type: none"> <li>• 765/400kV ICT – 1</li> <li>• 765kV ICT bay – 1 on Bus section-II*</li> <li>• 400kV ICT bay – 1 on Bus section-II*</li> </ul>
2.	2 nos. 400kV line bays on KPS3 400kV Bus Section-II for RE interconnection	<ul style="list-style-type: none"> <li>• 400kV line bays – 2 nos.</li> </ul>

*\*Bay(s) as may be required for completion of diameter (GIS) in one-and-half breaker scheme, shall also be executed by the TSP. Further, TSP of KPS3 shall provide space to carry out above augmentation works.*

**Implementation time frame:** 24 months from the date of award to implementing agency

**(b) ICT Augmentation at Bhuj PS for enabling RE injection**

Subsequent to the receipt of applications for Connectivity for 4000MW, Bhuj I PS was closed for further applications due to the non-availability of margins for RE injection considering N-1 criterion compliance. However, POWERGRID vide e-mail dated 12.06.2024, has confirmed the availability of space for another ICT. Hence augmentation of transformation capacity at Bhuj-I PS by 1x500MVA, 400/220kV ICT (10<sup>th</sup>) was planned to enable the injection of 500MW additional RE power. The scheme is currently under approval.

**Detailed scope of work:**

Sl. No.	Scope of the Transmission Scheme	Capacity/km
1.	Augmentation of Transformation capacity at Bhuj PS by 1x500MVA, 400/220kV ICT (10 <sup>th</sup> ) with associated ICT bays	<ul style="list-style-type: none"> <li>• 1x500MVA, 400/220kV ICT– 1 No.</li> <li>• 400kV ICT Bay: 1 No. (AIS)</li> <li>• 220kV ICT Bay: 1 No. (HGIS)</li> </ul>

--	--	--

**Note:** POWERGRID vide e-mail dated 06.06.2024 & 12.06.2024 has informed that 400kV ICT Bay will be AIS (in dia. of bus reactor) and 220kV ICT bay will be Hybrid/MTS with connection of ICT with 220kV bay possible only through EHV Cables / GIB

**Implementation timeframe:** 18 months from award to implementing agency

**(c) Augmentation of transformation capacity at 765/400 kV Lakadia S/s (WRSS XXI (A) Transco Ltd) in Gujarat – Part B**

765/400kV Lakadia S/s is existing and augmentation of transformation capacity by 2x500MVA 400/220kV ICTs are under implementation. Further, in view of the 2GW potential at Lakadia revived by MNRE vide letter dated 14.02.2024 & MoP letter dated 16.02.2024 and to enable the grant of Connectivity to the applicants in that area, the subject augmentation scheme is proposed.

The scheme was earlier discussed in parts (Part-B & Part-C) in the 17<sup>th</sup> & 18<sup>th</sup> NCT meetings wherein, considering the rapid pace of applications being received at Lakadia PS, it was decided to install all remaining ICTs and 220kV bays at Lakadia PS in one go so as to minimize multiple implementation time-lines. Hence, the scheme was again deliberated and approved under TBCB in the 20<sup>th</sup> NCT meeting held on 25.06.2024 with implementation time frame as mentioned.

**Detailed scope of work:**

Sl. No.	Scope of the Transmission Scheme	Capacity /km	Time-frame
1.	Installation of 2x500 MVA, 400/220 kV ICTs (3 <sup>rd</sup> & 4 <sup>th</sup> ) at Lakadia PS along with associated ICT bays	<ul style="list-style-type: none"> <li>• 400/220 kV, 1x500 MVA ICT – 2 Nos.</li> <li>• 400 kV ICT bay – 2 Nos.</li> <li>• 220 kV ICT bay – 2 Nos. (220 kV bus section-I)</li> </ul>	<b>18 months</b> from date of allocation to implementing agency
2.	Implementation of 220 kV line bay at Lakadia PS for TEQ Green Power XVII Private Limited (TGPXVIPL: 300 MW)	<ul style="list-style-type: none"> <li>• 220 kV line bay – 1 no. (220 kV bus section-I)</li> </ul>	<b>18 months</b> from date of allocation to implementing agency
3.	Implementation of 220 kV line bay at Lakadia PS for Arcelor Mittal Nippon Steel India Limited (AMNSIL: 350 MW)	<ul style="list-style-type: none"> <li>• 220 kV line bay – 1 no. (220 kV bus section-I)</li> </ul>	<b>18 months</b> from date of allocation to implementing agency
4.	Implementation of 220 kV line bay at Lakadia PS for Renew Solar (Shakti Eight) Private Limited (RS(S8)PL: 200 MW)	<ul style="list-style-type: none"> <li>• 220 kV line bay – 1 no. (220 kV bus section-I)</li> </ul>	<b>30.09.2026</b> (as per start date requested by applicant)*
5.	Creation of New 220 kV Bus Section-II at Lakadia PS along with 220 kV Sectionaliser arrangement between 220 kV Bus sec-I & Sec-II	<ul style="list-style-type: none"> <li>• 220 kV Bus Sectionaliser - 1 set</li> <li>• BC – 1 No.</li> <li>• TBC – 1 No.</li> </ul>	<b>18 months</b> from date of allocation to implementing agency

Sl. No.	Scope of the Transmission Scheme	Capacity /km	Time-frame
6.	Augmentation of transformation capacity at Lakadia PS by 4x500 MVA, 400/220 kV ICTs (5 <sup>th</sup> 6 <sup>th</sup> , 7 <sup>th</sup> & 8 <sup>th</sup> ) terminated on new 220 kV Bus Section-II		
6a.	2x500MVA ICTs (5 <sup>th</sup> & 6 <sup>th</sup> )	<ul style="list-style-type: none"> <li>• 500 MVA, 400/220 kV ICTs: 2 No.</li> <li>• 400 kV ICT bays: 2 Nos.</li> <li>• 220 kV ICT bays: 2 No. (New Bus Section-II)</li> </ul>	18 months from date of allocation to implementing agency
6b.	1x500MVA ICT (7 <sup>th</sup> )	<ul style="list-style-type: none"> <li>• 500 MVA, 400/220 kV ICT: 1 No.</li> <li>• 400 kV ICT bay: 1 No.</li> <li>• 220 kV ICT bays: 1 No. (New Bus Section-II)</li> </ul>	31.12.2026
6c.	1x500MVA ICT (8 <sup>th</sup> )	<ul style="list-style-type: none"> <li>• 500 MVA, 400/220 kV ICT: 1 No.</li> <li>• 400 kV ICT bay: 1 No.</li> <li>• 220 kV ICT bays: 1 No. (New Bus Section-II)</li> </ul>	30.06.2027
7.	Implementation of 220 kV line bay at Lakadia PS for Juniper Green Energy Private Limited (JGEPL) (Appl. No. 2200000376: 300 MW)	<ul style="list-style-type: none"> <li>• 220 kV line bay – 1 No. (New Bus Section-II)</li> </ul>	30.06.2027 (as per start date requested by applicant)
8.	Implementation of 220 kV line bay at Lakadia PS for TEQ Green Power XVI Pvt. Ltd. (TGPXVIPL) (Appl. No. 2200000398: 76MW)	<ul style="list-style-type: none"> <li>• 220 kV line bay – 1 No. (New Bus Section-II)</li> </ul>	30.09.2026 (as per start date requested by applicant)*
9.	Implementation of 220 kV line bay at Lakadia PS for Ganeko Solar Pvt. Ltd. (GSPL) (Appl. No. 2200000458: 290 MW)	<ul style="list-style-type: none"> <li>• 220 kV line bay – 1 No. (New Bus Section-II)</li> </ul>	31.12.2026 (as per start date requested by applicant)*
10.	Implementation of 220 kV line bay at Lakadia PS for Juniper Green Energy Private Limited (JGEPL) (Appl. No. 2200000500: 150 MW)	<ul style="list-style-type: none"> <li>• 220 kV line bay – 1 No. (New Bus Section-II)</li> </ul>	31.03.2027 (as per start date requested by applicant)
11.	Implementation of 220 kV line bay at Lakadia PS for Serentica Renewables India Private Limited (SRIPL) (Appl. No. 2200000610: 200 MW)	<ul style="list-style-type: none"> <li>• 220 kV line bay – 1 No. (New Bus Section-II)</li> </ul>	30.06.2026*
12.	Implementation of 220 kV line bay at Lakadia PS for RDS Solar Park	<ul style="list-style-type: none"> <li>• 220 kV line bay – 1 No. (New Bus Section-II)</li> </ul>	30.06.2026*

Sl. No.	Scope of the Transmission Scheme	Capacity /km	Time-frame
	Private Limited (RDSSPPL) (Appl. No. 2200000639: 350 MW)		
13.	Implementation of 220 kV line bay at Lakadia PS for Percentum Renewables Private Limited (PRPL) (Appl. No. 2200000673: 148 MW)	<ul style="list-style-type: none"> <li>• 220 kV line bay – 1 No. (New Bus Section-II)</li> </ul>	<b>30.06.2026*</b>
14.	Installation of 1x330 MVA 765 kV Bus Reactor (2nd) along-with associated bay	<ul style="list-style-type: none"> <li>• 330 MVA, 765 kV Bus Reactor: 1 No.</li> <li>• 765 kV BR bay: 1 No.</li> </ul>	<b>18 months</b> from date of allocation to implementing agency
15.	Augmentation of transformation capacity at Lakadia PS by 1x1500 MVA, 765/400 kV ICTs (3rd)	<ul style="list-style-type: none"> <li>• 1500 MVA, 765/400 kV ICT: 1 No.</li> <li>• 400 kV ICT bay: 1 No.</li> <li>• 765 kV ICT bay: 1 No.</li> </ul>	<b>18 months</b> from date of allocation to implementing agency

\*subject to minimum schedule of 18 months from the date of allocation to implementing agency.

**Note:** TSP of Lakadia S/s (WRSS XXI(A) Transco Ltd.) shall provide space for above augmentation works at Lakadia S/s

**Estimated Cost:** Rs. 636 Crs.

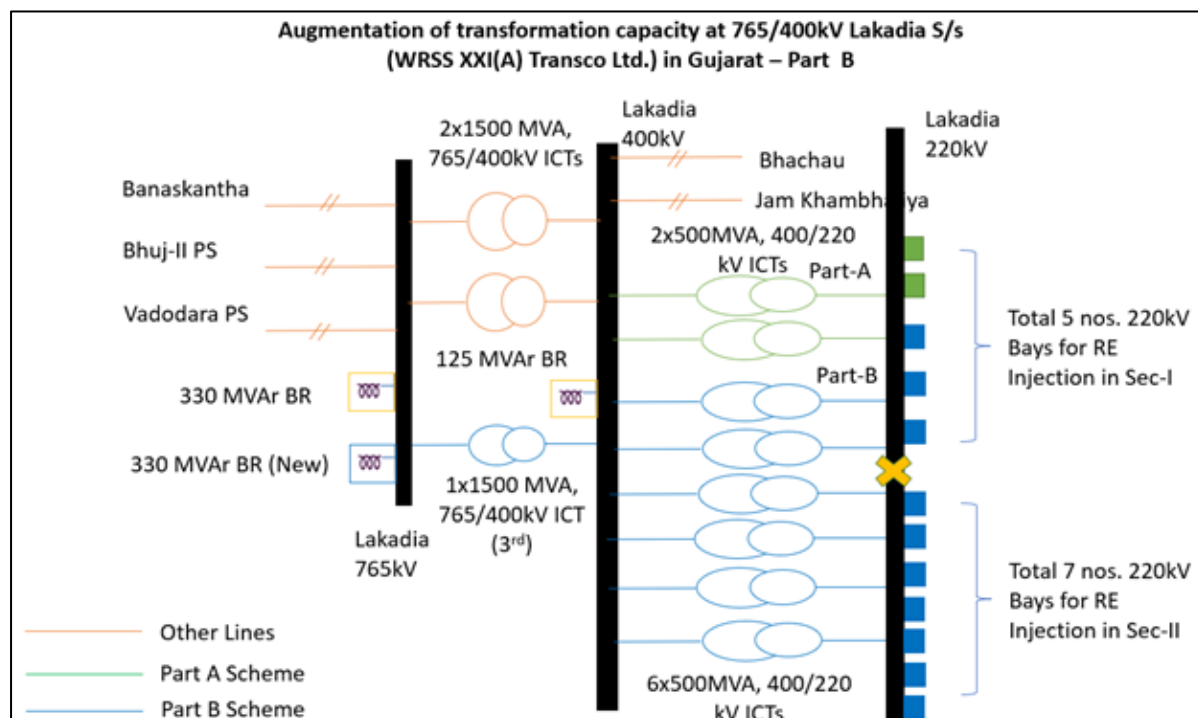

**(d) Augmentation of Transformation Capacity at 765/400/220kV Vadodara (GIS) S/s in Gujarat by 400/220kV, 1x500MVA ICT (3<sup>rd</sup>)**

3x1500MVA 765/400kV & 2x500MVA 400/220kV Vadodara (GIS) S/s is an existing substation implemented by POWERGRID through RTM Route.

However, during the joint study meeting held amongst CEA, CTU, GRID-INDIA & GETCO on 23.02.2024, the instant augmentation scheme was proposed to maintain redundancy and reliability during drawal of power at Vadodara S/s. This scheme also enables to maintain N-1 criterion compliance requirement. The scheme was discussed and approved in the 27<sup>th</sup> CMETS-WR meeting held on 01.04.2024. Further, the scheme was awarded to POWERGRID under RTM for implementation vide CTU OM dated 14.06.2024. The detailed scope of work of this scheme is given below.

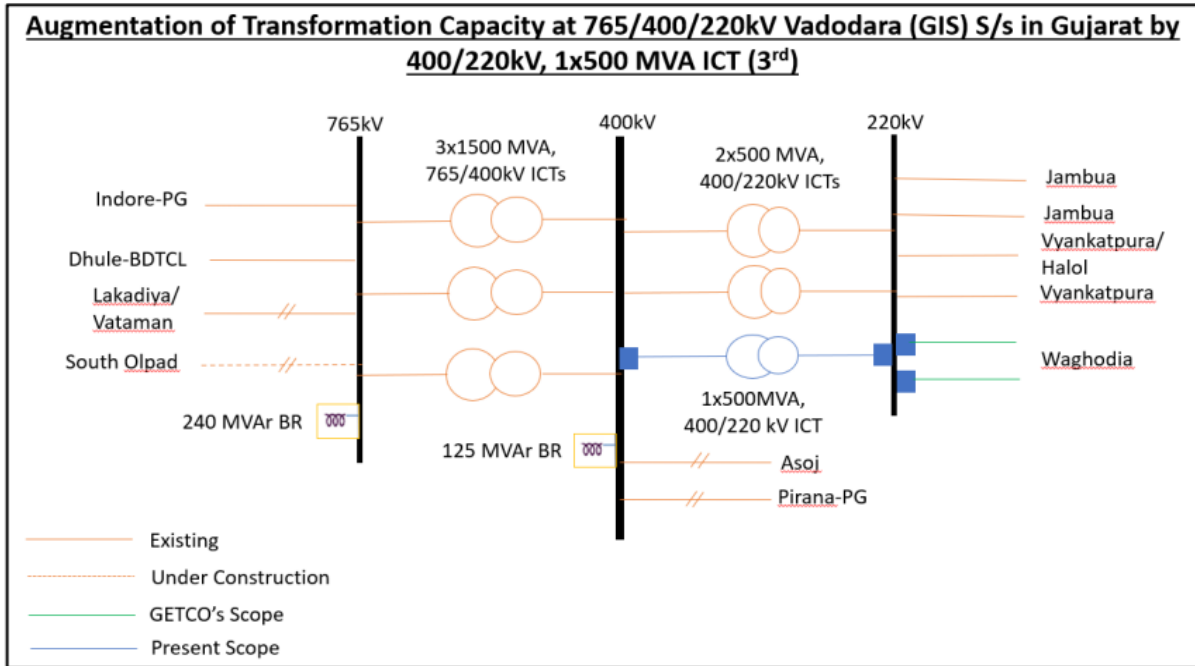

**Detailed scope of work:**

Sl. No.	Scope of the Transmission Scheme	Item Description
1.	Augmentation of Transformation Capacity at 765/400/220kV Vadodara (GIS) S/s in Gujarat by 400/220kV, 1x500MVA ICT (3 <sup>rd</sup> )	<ul style="list-style-type: none"> <li>• 400/220kV, 1x500MVA ICT – 1 No.</li> <li>• 400kV ICT bay (GIS) – 1 no.</li> <li>• 220kV ICT bay GIS) – 1 No.</li> <li>• 400kV GIS Bus duct (m) – 250m. approx.</li> <li>• 220 kV GIS Bus duct (m) – 450m. approx.</li> </ul>
2.	2 nos. 220kV bays at Vadodara S/s (for Vadodara (PG) – Waghodia D/c line)	<ul style="list-style-type: none"> <li>• 220kV line bays (GIS): 2 Nos.</li> <li>• 220kV GIS Bus duct (m) – 300m. approx.</li> </ul>

**Note:**

Implementation timeframe has been aligned with the time-frame for implementation of Vadodara (PG) – Waghodia 220kV D/c line as confirmed by GETCO.

**Implementation timeframe:** Mar-26 (with minimum implementation schedule of 21 months from SPV transfer).

**Estimated Cost:** Rs. 85.79 Crs.

**(e) Augmentation of transformation capacity at Banaskantha (Raghanesda) PS (GIS)**

400/220kV Banaskantha PS is an existing S/s with transformation capacity of 2x500MVA, 400/220kV ICTs, planned to enable injection of RE power from the 700MW GPCL’s Radhanesda Solar Power Park. M/s Sprng Power Earth Pvt. Ltd. was granted Connectivity for injection of 250MW RE power.

Subsequently, applications were received for additional 300MW Connectivity at Banaskantha PS. To enable the injection of additional 300MW RE power maintaining N-1 criterion compliance, the subject scheme was proposed. The scheme was deliberated and approved under TBCB in the 21<sup>st</sup> NCT meeting held on 06.08.2024 with implementation time frame of 24 months from the date of SPV transfer.

**Detailed scope of work:**

Sl. No.	Scope of the Transmission Scheme	Capacity /km
1.	Augmentation of transformation capacity at Banaskantha (Raghanesda) PS (GIS) by 2x500 MVA 400/220 kV ICTs (3 <sup>rd</sup> & 4 <sup>th</sup> )	<ul style="list-style-type: none"> <li>500 MVA, 400/220 kV ICTs: 2 Nos.</li> <li>400 kV ICT bays: 2 Nos. (+ 2 Nos. for dia completion with provision of Switchable LR)</li> <li>220 kV ICT bays: 2 Nos.</li> </ul>

**Implementation timeframe:** 24 months from the date of SPV transfer.

**Estimated Cost:** Rs. 172 Crs.

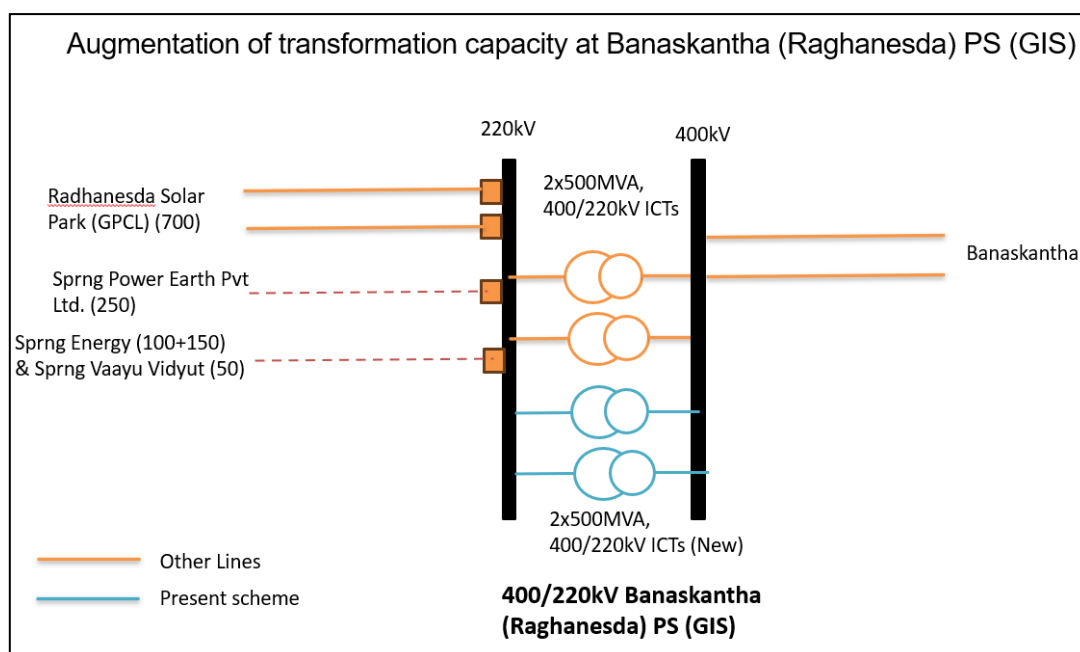

**(f) Transmission system to provide redundant power supply to Dholera area**

In order to provide power supply to the semiconductor manufacturing industries in Dholera SIR area of Gujarat, GETCO has already established 220/33kV Dholera S/s along with Panchham – Dholera 400kV D/c line which is presently charged at 220kV level. However, in view of a redundant 2<sup>nd</sup> source of power, GETCO vide letter dated 22.07.2024, has proposed ISTS connectivity from Vataman substation, for drawal of 150-200MW at new proposed Dholera-2 S/s of GETCO in Jan-26 time-frame.

765kV Vataman Switching Substation is under implementation with SCOD of Dec’25. Subsequently, implementation of 2x1500MVA 765/400kV ICTs at Vataman S/s was approved in the 20<sup>th</sup> NCT meeting to enable evacuation of power from offshore wind projects in Gujarat in matching timeframe with offshore wind (Mar’29).

The interconnection of Vataman S/s (ISTS) with 220kV Dholera-2 S/s proposed by GETCO would require preponement of 2x1500MVA 765/400kV ICTs (agreed for offshore wind projects), from Mar-29 to an earlier time-frame as well as Installation of 2x500MVA 400/220kV ICTs and 2 nos. 220kV line bays at Vataman S/s. In this regard, the subject scheme was agreed for with the following scope of work in the 31<sup>st</sup> CMETS-WR held on 02.08.2024. The scheme was deliberated and approved under TBCB in the 22<sup>nd</sup> NCT meeting held on 23.08.2024 with implementation time frame as mentioned below:

**Detailed scope of work:**

Sl. No.	Scope of the Transmission Scheme	Capacity /km
<b>A. Transmission System for Offshore Wind (required to be preponed)</b>		
1.	Creation of 400kV switchyard along with Installation of 2x1500 MVA, 765/400 kV ICTs at Vataman (AIS) with 2x125 MVar (420 kV) Bus Reactors	<ul style="list-style-type: none"> <li>• 765/400kV, 1500 MVA, ICTs – 2 nos. (7x500MVA incl. spare unit)</li> <li>• 765kV ICT bays – 2 nos.</li> <li>• 400kV ICT bays – 2 nos.</li> <li>• 2x125 MVAR, 420kV Bus Reactor – 1 no.</li> <li>• 400kV Bus Reactor bay – 2 no.</li> </ul>
<b>B. Additional Transmission System Proposed for redundant power supply to Dholera area</b>		
2.	Creation of 220kV switchyard along with Installation of 2x500 MVA, 400/220 kV ICTs at Vataman (AIS)	<ul style="list-style-type: none"> <li>• 400/220kV, 500 MVA, ICTs – 2 nos.</li> <li>• 400kV ICT bays – 2 nos.</li> <li>• 220kV ICT bays – 2 nos.</li> </ul>
3.	2 Nos. 220kV line bays for Vataman – Dholera-2(GETCO) 220kV D/c line	<ul style="list-style-type: none"> <li>• 220kV line bays – 2 nos.</li> </ul>

**Note:** GETCO shall implement Vataman – Dholera-2(GETCO) 220kV D/c line in matching time-frame

**Implementation time-frame:** 18 months from award to implementing agency

**Estimated cost:** Rs. 110 Crs.

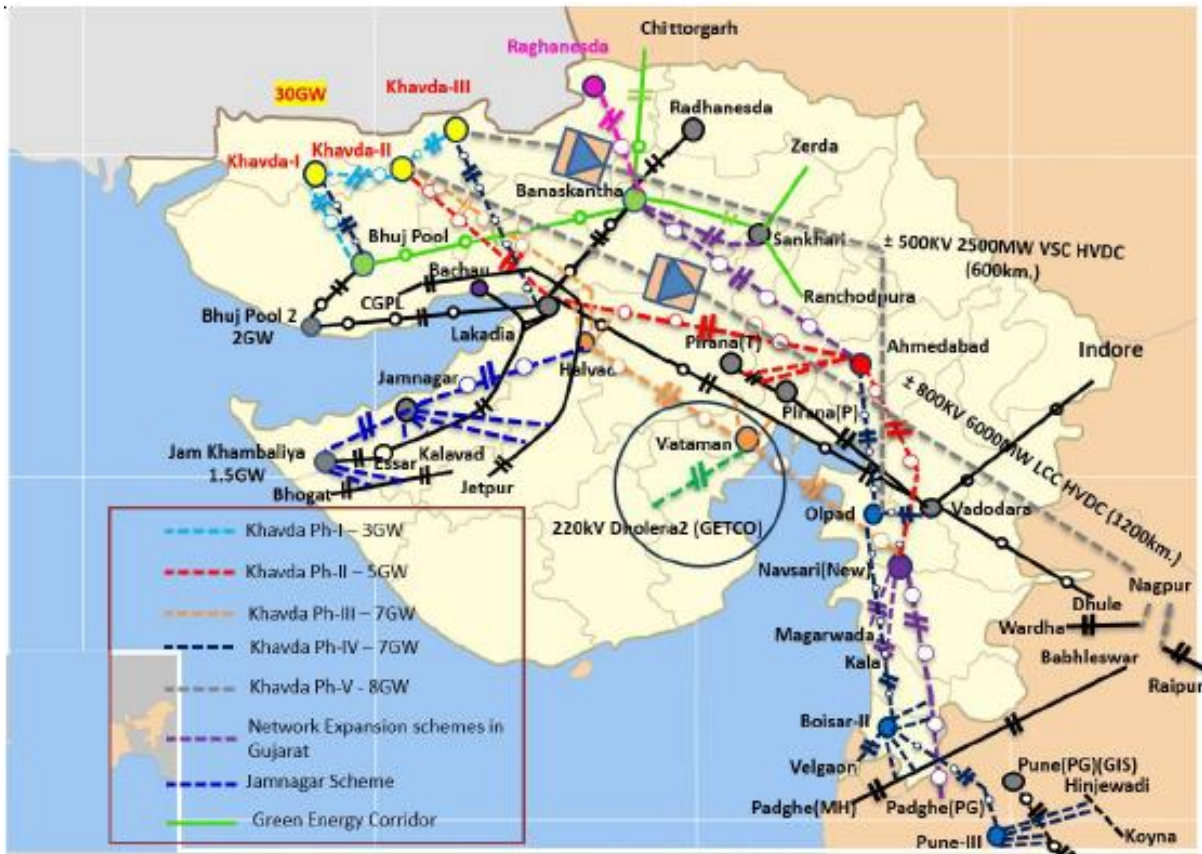

**(g) Bays at Vataman S/s for Vataman – Saurashtra 765kV D/c line**

Establishment of 2x1500MVA, 765/400kV Saurashtra S/s (near Rajkot), 765 kV D/C Vataman (ISTS) – Saurashtra line (with bays at both ends) (along with other transmission elements) is being taken up by GETCO for implementation. In this regard, GETCO vide letter dated 30.05.2024, has requested for implementation of 2 nos. 765kV bays at Vataman (ISTS) S/s for Saurashtra – Vataman 765kV D/c line (expected by Mar’27) under ISTS to ensure smooth execution of work. The request from GETCO was agreed for in the 30<sup>th</sup> CMETS-WR meeting held on 02.07.2024.

**Detailed scope of work:**

Sl. No.	Scope of the Transmission Scheme	Capacity /km
1.	2 No. 765kV bays at Vataman S/s (of Vataman Tr. Limited) for Vataman – Saurashtra 765kV D/c line of GETCO	765kV line bay – 2 No.

**Implementation time-frame:** 31.03.2027

**(h) 220kV line bays at Vapi-II S/s for LILO of 220 KV Chikhli – Vapi 220kV S/c line at Vapi-II**

Establishment of Vapi-II with 2x500MVA, 400/220kV ICTs & 4 nos. 220kV bays (for GETCO) is already being implemented under ISTS by Sterlite Grid 4 Ltd. Subsequently, Transmission scheme for

implementation of LILO of Kakrapar-Vapi 220kV D/c (ISTS) line & LILO of 220 KV Chikhli – Vapi 220kV S/c line at Vapi-II S/s was taken up by GETCO requiring 2 additional bays at Vapi-II S/s. In this regard, GETCO, vide letter dated 30.05.2024, has requested for implementing the above two bays (in addition to the 4 bays granted earlier) under ISTS.

Subsequent to the deliberations regarding the implementation timeframe, the subject scheme was agreed for implementation under ISTS in the 31<sup>st</sup> CMETS-WR held on 02.08.2024 and is currently under approval.

**Detailed scope of work:**

Sl. No.	Scope of the Transmission Scheme	Capacity /km
1.	2 nos. 220kV line bays at Vapi-II S/s for LILO of 220 KV Chikhli – Vapi 220kV S/c line at Vapi-II	220kV line bays – 2 Nos. (GIS)

**Note:** GETCO shall match LILO of 220 KV Chikhli – Vapi 220kV S/c line at Vapi-II with the time-frame of commissioning of 220kV bays under ISTS.

**Implementation time-frame:** 21 months from award to implementing agency.

**(i) Implementation of 220kV line bays at Bhuj PS for RE Interconnection**

765/400/220kV Bhuj PS is an existing substation of POWERGRID with 4x1500MVA, 765/400kV ICTs & 8x500MVA 400/220kV ICTs. 9<sup>th</sup> 400/220kV ICT is being implemented by POWERGRID with schedule of 01.07.2025. M/s Indianoil NTPC Green Energy Private Limited (INGEPL) has applied for Connectivity vide application no. 2200000634 for 600MW RE power injection from 30.06.2026. The subject scheme is planned to enable the Connectivity of M/s INGEPL.

**Detailed scope of work:**

Sl. No.	Scope of the Transmission Scheme	Capacity /km
1.	Implementation of 2 nos. 220kV line bays at Bhuj PS for Interconnection of Solar Project of Indianoil NTPC Green Energy Private Limited (INGEPL) (Appl. No. 2200000634)	2 Nos. Hybrid/MTS Bays

**Implementation time-frame:** 30.06.2026

**Estimated cost:** Rs. 12.7 Crs.

**(j) Transmission System for evacuation of RE power from Raghnesda area of Gujarat – 3 GW under Phase-I**

Raghnesda region in Banaskantha District of Gujarat has been declared a potential Renewable Energy (RE) zone with potential of 5 GW in the initial phase (i.e. related to 1 GW RE park of GPCL and 4 GW RE park of M/s Torrent for which land allocation by Government of Gujarat is under process). 2.5GW out of 4GW Solar Capacity of Torrent and 0.5GW out of 1GW RE park of GPCL is being considered

under ISTS under Phase-I planning. Presently, connectivity under GNA has been received for 0.6GW (3x200 MW from M/s Sprng) at Raghanesda PS.

The scheme was discussed and agreed upon in the WRPC meeting held on 27.03.2024. Subsequently, the scheme was also deliberated and approved in the 20<sup>th</sup> NCT meeting held on 25.06.2024 for implementation under TBCB route with implementation timeframe of 30 months.

**Detailed scope of work:**

Sl. No.	Scope of the Transmission Scheme	Capacity/ kM
1.	<p>Establishment 3x1500 MVA, 765/400 kV Substation near Raghanesda (GIS) with 2x330 MVAR, 765 kV bus reactor and 2x125 MVAR, 420 kV bus reactor</p> <p><b>Future provision (space for):</b></p> <ul style="list-style-type: none"> <li>• 765/400 kV ICT along with bays- 5 Nos. (1 No. in Sec-I &amp; 4 Nos. on Sec-II)</li> <li>• 765 kV line bays along with switchable line reactors – 10 Nos. (4 Nos. on Sec-I &amp; 6 Nos. on Sec-II)</li> <li>• 765 kV Bus Reactor along with bay: 2 Nos. (on Sec-II)</li> <li>• 765 kV Sectionalizer: 1 -set</li> <li>• 400 kV line bays along with switchable line reactors– 12 Nos. (4 Nos. on Sec-I &amp; 8 Nos. on Sec-II)</li> <li>• 400/220 kV ICT along with bays - 8 Nos. (4 Nos. on each 400 kV Section)</li> <li>• 400 kV Bus Reactor along with bays: 2 Nos. (Sec-II)</li> <li>• 400 kV Sectionalization bay: 1- set</li> <li>• 220 kV line bays: 12 Nos. (6 Nos. on each 220 kV Section)</li> <li>• 220 kV Sectionalization bay: 1 set</li> <li>• 220 kV BC: 1 No.</li> <li>• Establishment of 6000 MW, ± 800 kV Raghanesda (HVDC) [LCC] terminal station (4x1500 MW) along with associated interconnections with 400 kV HVAC Switchyard &amp; all associated equipment (incl. filters)/bus extension, etc.</li> </ul>	<ul style="list-style-type: none"> <li>• 765/400 kV, 1500 MVA ICT – 3 Nos. (10x500 MVA single phase units including one spare ICT Unit)</li> <li>• 765 kV ICT bays – 3 Nos.</li> <li>• 400 kV ICT bays – 3 Nos.</li> <li>• 765 kV Line bays – 2 Nos.</li> <li>• 1x330 MVAR, 765 kV bus reactor- 2 Nos. (7x110 MVAR single phase Reactors including one spare Unit for bus /line reactor)</li> <li>• 765 kV Bus reactor bay – 2 Nos.</li> <li>• 125 MVAR, 420 kV reactor- 2 Nos.</li> <li>• 400 kV Reactor bay- 2 Nos.</li> <li>• 400 kV line bays - 4 Nos. (for interconnection of RE Projects)</li> </ul>
2.	Raghanesda (GIS) – Banaskantha (PG) 765 kV D/c line	95 km
3.	2 Nos. 765 kV line bays at Banaskantha (PG) S/s	765 kV line bays – 2 Nos.

**Note:**

- TSP of Banaskantha S/s (POWERGRID) shall provide space for scope at Sl. 3 above.

**Implementation timeframe:** 30 months from the date of SPV transfer.

**Estimated Cost:** Rs. 1855 Crs.

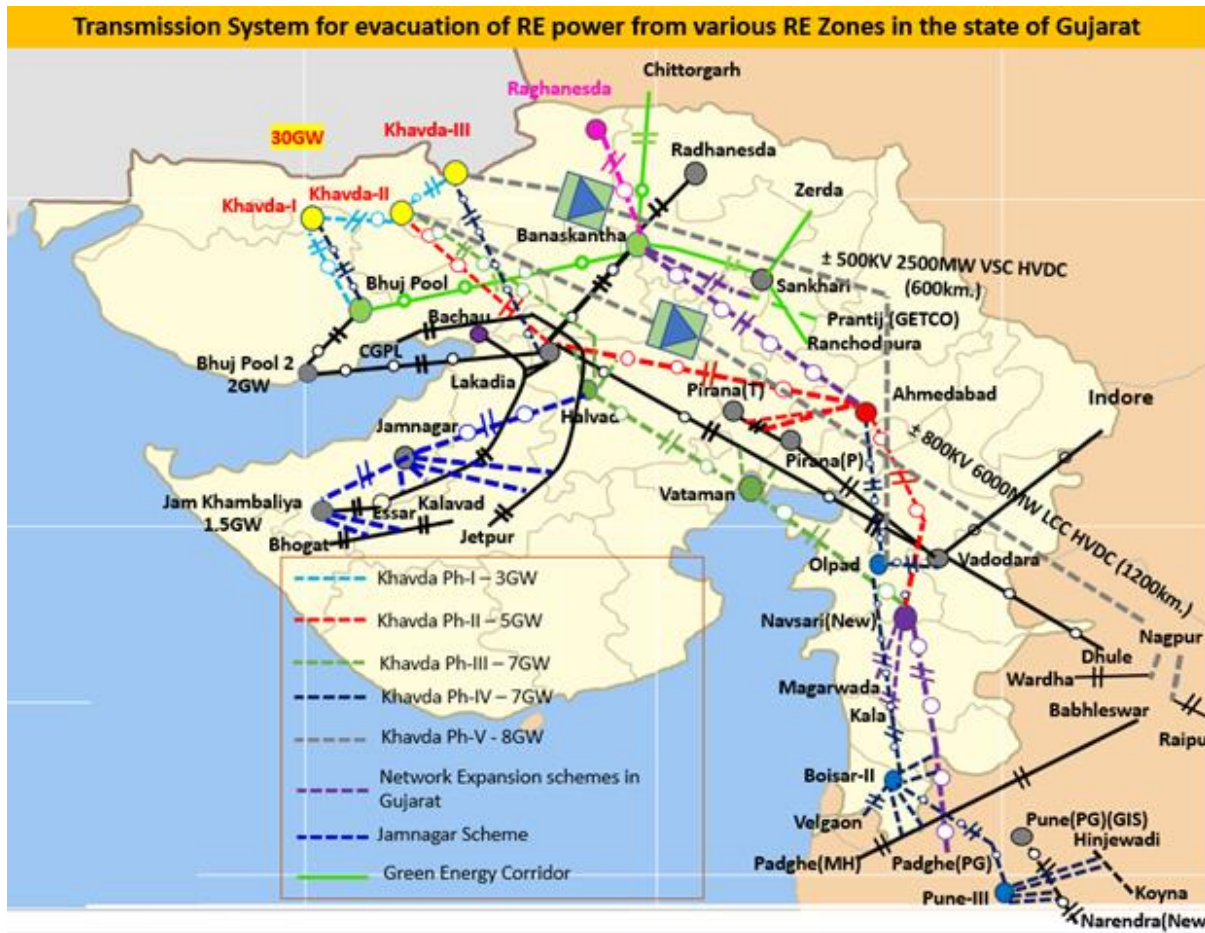

**(k) Transmission System for evacuation of Green Hydrogen/Ammonia potential in Kandla area of Gujarat (Phase-I: 3 GW)**

Hon’ble Prime Minister of India has announced Hydrogen Mission on 15th August, 2021 which is a major step towards decarbonizing the energy system and thereby complementing other decarbonization technologies like renewable power and biofuels. Ministry of Power has issued Hydrogen Policy wide letter dated 17th February 2022 with a motive to facilitate the transition from fossil fuel/ fossil fuel-based feedstock to Green Hydrogen/ Green Ammonia both as energy carriers and chemical feedstock for different sectors.

During the further round of discussions in the meetings held by Hon’ble MNRE & CEA, regarding the capacity, different locations, tentative timelines and power demand etc., it was concluded that, there is a power drawal requirement of 2.2GW by 2027-28 progressively increasing up to 6GW by 2030 in the Kandla area of Gujarat.

In view of the envisaged network requirements by the year 2027-28, the subject scheme is proposed to cater to the power drawal requirement of up to 3GW under Phase-I with implementation timeframe of 24 months (by the year 2027-28).

The scheme was discussed in 49<sup>th</sup> WRPC meeting held on 03.05.2024 and in the 21<sup>st</sup> NCT meeting held on 06.08.2024 wherein it was recommended for implementation under TBCB route with the following scope of work.

**Detailed scope of work;**

Sl. No.	Scope of the Transmission Scheme	Capacity/line length km
1.	<p>Establishment of 3X1500 MVA 765/400 kV Kandla (GIS) with 2X330 MVAR 765 kV bus reactor and 2X125 MVAR 420 kV bus reactor.</p> <p><b>Future Scope</b> (Space for):</p> <ul style="list-style-type: none"> <li>• 765/400 kV ICT along with bays-3 Nos. (on Sec-II)</li> <li>• 765 kV line bays along with switchable line reactors – 2 Nos. (on Sec-I) &amp; 6 Nos. (on Sec-II)</li> <li>• 765 kV Bus Reactor along with bay: 2 Nos. (on Sec-II)</li> <li>• 765 kV Sectionalizer: 1 -set</li> <li>• 400 kV line bays along with switchable line reactors– 14 Nos. (6 on Sec-I &amp; 8 on Sec-II)</li> <li>• 400/220 kV ICT along with bays-6 Nos. (3 Nos. each on Sec-I &amp; Sec-II)</li> <li>• 400 kV Bus Reactor along with bays: 2 Nos. (Sec-II)</li> <li>• 400 kV Sectionalization bay: 1-set</li> <li>• 220 kV line bays: 12 Nos. (6 nos. each on Sec-I &amp; Sec-II)</li> <li>• 220 kV Sectionalization bay: 1set</li> <li>• 220 kV BC: 2 Nos.</li> <li>• STATCOM (<math>\pm</math>400 MVAR) along with 2x125 MVA MSC &amp; 1x125 MVA MSR and associated bays-2Nos. (1 on 400kV Sec-I and 1 on 400 kV Sec-II)</li> </ul>	<ul style="list-style-type: none"> <li>• 765/400 kV, 1500 MVA ICT-3</li> <li>• 765 kV ICT bays- 3</li> <li>• 400 kV ICT bays- 3</li> <li>• 330 MVAR 765 kV bus reactor-2</li> <li>• 125 MVAR 420 kV bus reactor-2</li> <li>• 765 kV reactor bay- 2</li> <li>• 765 kV line bay- 2</li> <li>• 400 kV reactor bay- 2</li> <li>• 500 MVA, 765/400 kV 1-Ph Spare ICT-1</li> <li>• 110 MVAR, 765 kV, 1-ph reactor (spare unit for line/bus reactor)-1</li> </ul>
2.	Halvad – Kandla(GIS) 765kV D/c line	140 km
3.	2 Nos. of 765kV line bays at Halvad for termination of Halvad – Kandla 765kV D/c line	<ul style="list-style-type: none"> <li>• 765 kV line bays– 2 Nos. (for Halvad end)</li> </ul>

Sl. No.	Scope of the Transmission Scheme	Capacity/line length km
4.	240 MVAR switchable line reactors on each ckt at Kandla (GIS) end of Halvad – Kandla 765kV D/c line (with NGR bypass arrangement)	<ul style="list-style-type: none"> <li>• 240 MVAR, 765 kV switchable line reactor- 2 Nos.</li> <li>• Switching equipment for 765 kV line reactor- 2 Nos.</li> <li>• 80 MVAR, 765 kV, 1-ph reactor (spare unit for line/bus reactor)-1 Nos.</li> </ul>
5.	±400 MVAR STATCOM along with 2x125 MVAR MSC & 1x125 MVAR MSR at Kandla(GIS) 400 kV Bus section-I	<ul style="list-style-type: none"> <li>• ±400 MVAR STATCOM along with 2x125 MVAR MSC &amp; 1x125 MVAR MSR</li> <li>• 400 kV bay – 1 Nos.</li> </ul>

**Note:**

As per initial discussions with Deen Dayal Port Authority w.r.t. land allocation done to various Green Hydrogen/Ammonia developers in Kandla area, Kandla S/s is proposed to be located near Bhimasar area and line length of Kandla-Halvad line has been considered accordingly. However, exact location of the substation is to be finalized by the surveying agency in consultation with Deen Dayal Port Authority and other stakeholders.

Further, TSP of Halvad S/s shall provide space for scope at Sl. 3 above.

**Implementation timeframe:** 24 months from the date of SPV transfer.

**Estimated Cost:** Rs. 2775 Crs.

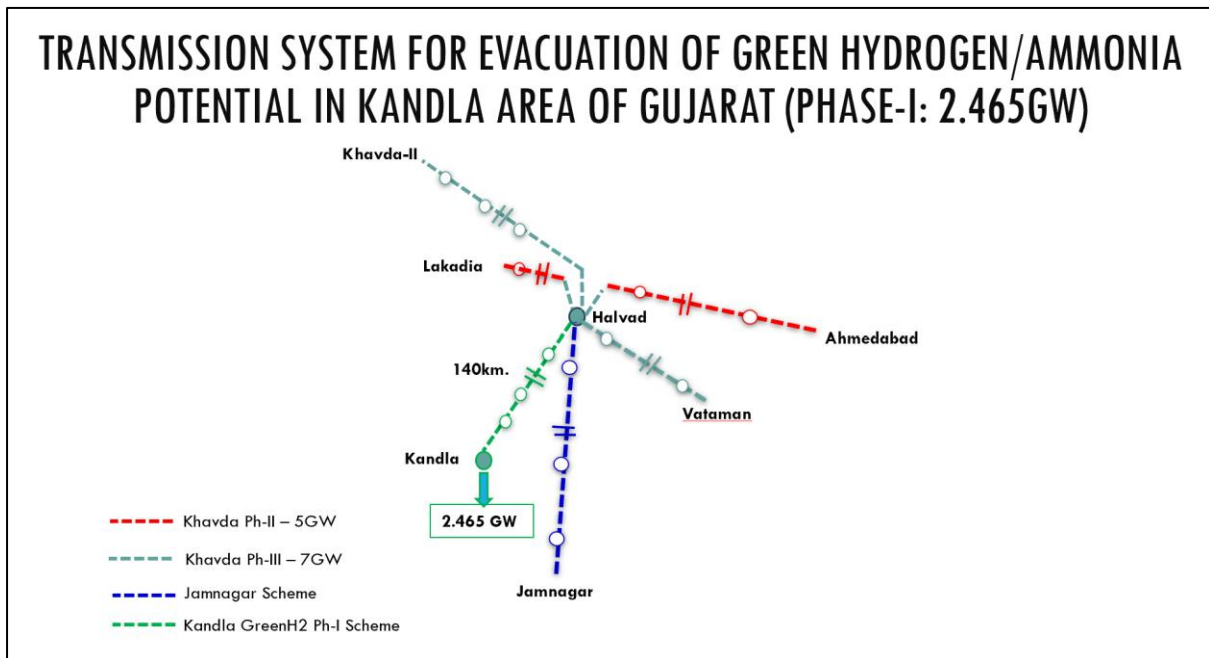

**(I) Transmission System for supply of power to Green Hydrogen/Green Ammonia manufacturing potential in Mundra area of Gujarat under Phase-I**

During the meetings held by Hon’ble MNRE & CEA, it was concluded that, there is a power drawal requirement of 6GW by 2027-28 progressively increasing up to 22GW by 2030 in the Mundra area of Gujarat.

765/400kV Navinal (Mundra) (GIS) was planned with 4x1500MVA, 765/400kV ICTs through LILO of Bhuj-II – Lakadia 765 kV D/c line at Navinal (Mundra) (GIS) S/s for meeting the demand of bulk consumers (3000MW) and for meeting the demand of Green Hydrogen/Ammonia manufacturers (1500MW) under Phase-I Part-A. This scheme is currently under bidding.

Further, in view of the envisaged network requirement by the year 2027-28, the subject scheme is proposed in two parts to cater to the power drawal requirement of up to 10.5GW under Phase-I with scope of work as follows.

**Transmission System for evacuation of Green Hydrogen/Ammonia potential in Mundra area of Gujarat under Phase-I: Part B1 scheme (6GW at Navinal S/s):**

- Augmentation of Transformation capacity at 765/400 kV Navinal (Mundra) S/s (GIS) by 2x1500 MVA ICTs (New Bus Section-II)
- Navinal(Mundra) (GIS) – Bhuj 765kV D/c line (70km.)
- $\pm 400$ MVAr STATCOM at Navinal(Mundra) (GIS) 400kV Bus section-I
- $\pm 400$ MVAr STATCOM at Navinal(Mundra) (GIS) 400kV Bus section-II

**Transmission System for evacuation of Green Hydrogen/Ammonia potential in Mundra area of Gujarat under Phase-I: Part B2 scheme (3.5GW at Navinal-II S/s):**

- Establishment of 6x1500 MVA, 765/400 kV Navinal-II (Mundra) S/s (GIS) with 2x330 MVAr, 765 kV & 2x125MVAr, 420 kV bus reactors (In 2 bus sections)
- LILO of KPS3 (GIS) – Lakadia 765kV D/c line at Navinal-II (Mundra) (GIS) S/s
- Navinal-II (Mundra) (GIS) – Bhuj-II (GIS) 765kV D/c line
- $\pm 400$ MVAr STATCOM at Navinal-II (Mundra) (GIS) 400kV Bus section-I
- $\pm 400$ MVAr STATCOM at Navinal-II (Mundra) (GIS) 400kV Bus section-II

The scheme was discussed in 49<sup>th</sup> WRPC meeting held on 03.05.2024 and in the 21<sup>st</sup> NCT meeting held on 06.08.2024 wherein it was decided that the scheme may again be examined jointly by CEA, CTUIL and Grid India.

Accordingly, considering the space availability for adequate reactive power compensation & drawal of huge load (more than 10GW) from a single substation (Navinal) from resiliency point of view, the scope of work was modified in a subsequent meeting held on 14.08.2024. Subsequently, in 22<sup>nd</sup> NCT meeting held on 23.08.2024, NCT recommended Transmission system for supply of power to Green Hydrogen/Ammonia manufacturing potential in Mundra area of Gujarat under Phase-I: Part B1 scheme (3 GW at Navinal S/s)” as mentioned below:

**Detailed scope of work:**

**Transmission System for evacuation of Green Hydrogen/Ammonia potential in Mundra area of Gujarat under Phase-I: Part B1 scheme (3GW at Navinal S/s)**

- Augmentation of Transformation capacity at 765/400 kV Navinal(Mundra) S/s (GIS) by 2x1500 MVA ICTs (New Bus Section-II)
- Navinal(Mundra) (GIS) – Bhuj 765kV D/c line (70km.)
- $\pm 300$ MVAr STATCOM along with MSC (2x125 MVAr) & MSR (1x125 MVAr) at Navinal (Mundra) (GIS) 400kV Bus section-I
- $\pm 300$ MVAr STATCOM along with MSC (2x125 MVAr) & MSR (1x125 MVAr) at Navinal (Mundra) (GIS) 400kV Bus section-II

**Estimated cost:** Rs. 2817 Crs.

**Implementation timeframe:** 36 Months from date of allocation to implementing agency

In 22<sup>nd</sup> NCT meeting, it was decided that initial applications for drawal of power at Navinal from Green Hydrogen/Ammonia manufacturers would be accommodated at Navinal-I S/s (cumulative upto 4.5 GW). Therefore, Part B2 scheme (details given below) may be deferred at present and would be taken up for deliberation subsequently based on receipt of applications from Green Hydrogen/Ammonia manufacturers at Navinal-I S/s.

**Transmission System for evacuation of Green Hydrogen/Ammonia potential in Mundra area of Gujarat under Phase-I: Part B2 scheme (7.5GW at Navinal-II S/s)**

- Establishment of 6x1500 MVA, 765/400 kV Navinal-II (Mundra) S/s (GIS) with 2x330 MVAR, 765 kV & 2x125MVAR, 420 kV bus reactors (In 2 bus sections)
- LILO of KPS3 (GIS) – Lakadia 765kV D/c line at Navinal-II (Mundra) (GIS) S/s
- Navinal-II (Mundra) (GIS) – Bhuj-II (GIS) 765kV D/c line
- ±2x300MVAR STATCOMs at Navinal-II (Mundra) (GIS) 400kV Bus section-I
- ±2x300MVAR STATCOMs at Navinal-II (Mundra) (GIS) 400kV Bus section-II

**Estimated cost:** Rs. 6405 Crs.

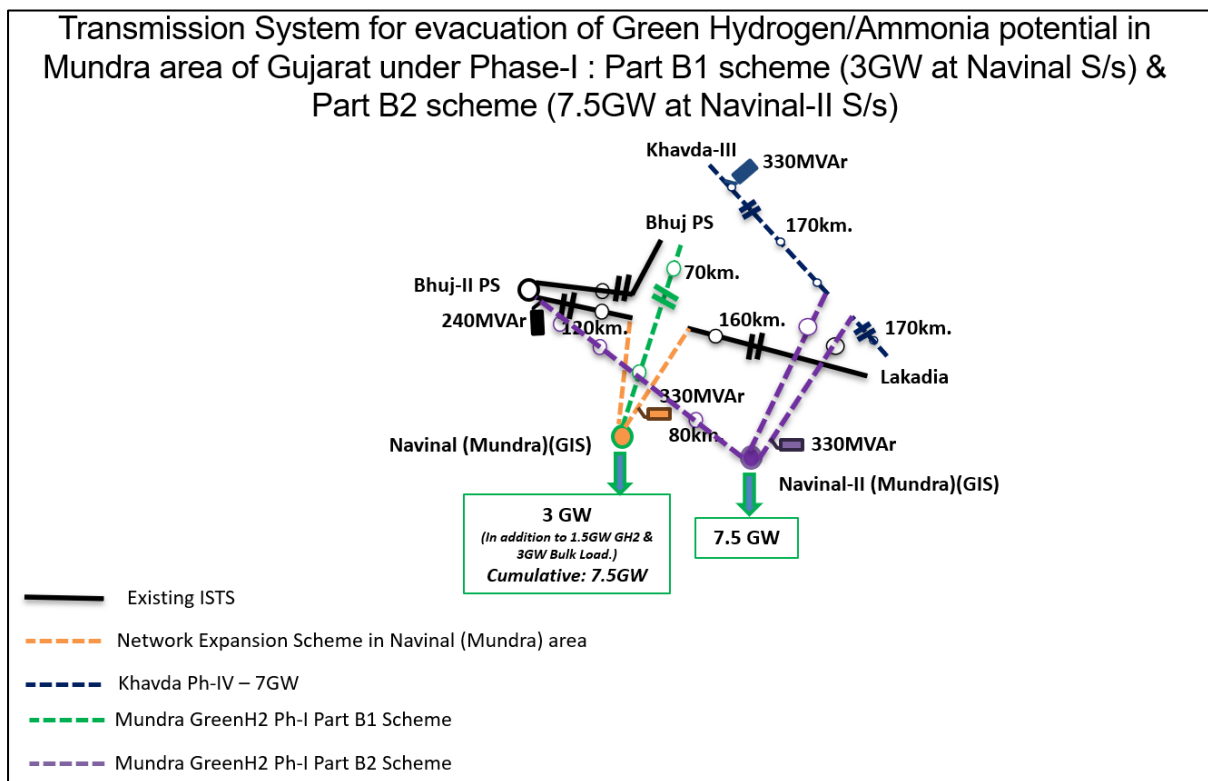

**(m) Transmission System for Offshore Wind Zone Phase-1 (500 MW VGF off the coast of Gujarat for Subzone B3)**

MNRE has identified about 30 GW Offshore wind potential each off the coast of Gujarat and Tamil Nadu. Initially 5 GW Offshore wind potential each at Gujarat (CUF – 38%) and Tamil Nadu (CUF – 48%) has been prioritized for implementation wherein 2 GW transmission capacity (1 GW each off the

coast of Gujarat and Tamil Nadu) will be developed in Phase-I and further 4 GW each off the coast of Gujarat and Tamil Nadu shall be developed subsequently.

In this regard, following broad decisions were taken in the meeting held on 22.12.2023, regarding tentative timelines for the offshore wind energy projects:

- 500 MW VGF project off-Gujarat coast to be commissioned by March 2028. Tender for the project to be published by March 2024.
- 500 MW VGF project off-Tamil Nadu coast to be commissioned by March 2029. Tender for the project to be published by March 2025.
- 4 GW non-VGF project off-Tamil Nadu coast to be commissioned in FY 2029- 30. Tender for the projects to be published on 01.02.2024.
- Non-VGF project off-Gujarat coast will be tendered based on the response for the Tamil Nadu non-VGF project

The scheme was discussed and agreed upon in the WRPC meeting held on 27.03.2024. Further, in a meeting held on 14.06.2024 under the chairmanship of Hon'ble MoP & MNRE, it was decided that the subject project may be awarded to POWERGRID for implementation under RTM.

As per the press release dated 19.06.2024 from PIB, the Union Cabinet have approved the Viability Gap Funding (VGF) scheme for offshore wind energy projects for installation and commissioning of 1 GW of offshore wind energy projects. The scheme was deliberated and approved in the 20<sup>th</sup> NCT meeting held on 25.06.2024 for implementation by POWERGRID under RTM mode. The subject scheme was awarded to POWERGRID vide CTU letter dated 20.08.2024. The detailed scope of work is given below.

**Detailed scope of work:**

Sl. No.	Scope of the Transmission Scheme	Capacity /km
<b>A. Transmission System onwards Onshore Pooling Station</b>		
1.	<p>Establishment of 2x500 MVA, 400/220 kV Mahuva Onshore Pooling Station (GIS) (Mahuva PS) alongwith 1x125 MVAR, 420 kV bus reactor (with space provision for upgradation to 765 kV level to cater to future Offshore Wind Projects adjacent to B3, B4, B5 pockets in future)</p> <p><b>Future Space Provisions:</b></p> <ul style="list-style-type: none"> <li>i. 765/400 kV ICT along with bays- 6 Nos.</li> <li>ii. 765 kV line bays along with switchable line reactors – 8 Nos.</li> <li>iii. 765 kV Bus Reactor along with bay: 2 Nos.</li> <li>iv. 765 kV Sectionaliser: 1 -set</li> <li>v. 400 kV line bays along with switchable line reactors– 8 Nos.</li> <li>vi. 400/220 kV ICT along with bays -8 Nos.</li> </ul>	<ul style="list-style-type: none"> <li>• 400/220kV, 500 MVA, ICTs – 2 nos.</li> <li>• 400kV ICT bays – 2 nos.</li> <li>• 220kV ICT bays – 2 nos.</li> <li>• 1x125 MVAR, 420kV Bus Reactor – 1 no.</li> <li>• 400kV Bus Reactor bay – 1 no.</li> <li>• 400kV line bays – 2 nos. (for termination of Mahuva Onshore PS (GIS) – Vataman 400 kV D/c line)</li> <li>• 220kV line bays – 2 nos. (for termination of B3-OSS-1 – Mahuva Onshore PS 220 kV 2xS/c (3 core) cables)</li> <li>• 220 kV Bus Coupler (BC) Bay – 1 no.</li> </ul>

Sl. No.	Scope of the Transmission Scheme	Capacity /km
<b>A. Transmission System onwards Onshore Pooling Station</b>		
	<ul style="list-style-type: none"> <li>vii. 400 kV Bus Reactor along with bays: 3 Nos.</li> <li>viii. 400 kV Sectionalization bay: 1- set</li> <li>ix. 220 kV line bays: 16 Nos.</li> <li>x. 220 kV Sectionalization bay: 1 set</li> <li>xi. 220 kV BC and TBC: 1 No.</li> <li>xii. STATCOM (<math>\pm 300</math> MVAR) along with associated bay at 220 kV - 3 Nos.</li> <li>xiii. 220kV Bus Reactor along with bays: 7 Nos.</li> <li>xiv. VSR (420kV, 1x125 MVAR Variable Bus Shunt Reactor with OLTC with control range between 50 – 125 MVAr for each VSR) along with associated bay at 400 kV – 3 Nos.</li> </ul>	
2.	Creation of 400kV switchyard along with Installation of 2x1500 MVA, 765/400 kV ICTs at Vataman (AIS) with 2x125 MVAr (420 kV) Bus Reactors	<ul style="list-style-type: none"> <li>• 765/400kV, 1500 MVA, ICTs – 2 nos. (7x500MVA incl. spare unit)</li> <li>• 765kV ICT bays – 2 nos.</li> <li>• 400kV ICT bays – 2 nos.</li> <li>• 2x125 MVAR, 420kV Bus Reactor – 1 no.</li> <li>• 400kV Bus Reactor bay – 2 nos.</li> </ul>
3.	2 nos. 400kV bays at Vataman for termination of Mahuva Onshore PS (GIS) – Vataman 400 kV D/c line	<ul style="list-style-type: none"> <li>• 400kV line bays – 2 nos.</li> </ul>
4.	Mahuva Onshore PS (GIS) – Vataman 400 kV D/c line (Quad ACSR/AAAC/AL59 moose equivalent) with 63MVAr & 50 MVAr, 420 kV switchable line reactors on each ckt at Mahuva & Vataman ends respectively.	<p>Line length: 190 km</p> <p>420 kV, 63 MVAr switchable line reactors at Mahuva S/s end– 2 Nos. Switching equipment for 420 kV, 63 MVAr switchable line reactors at Mahuva S/s end – 2 no</p> <p>420 kV, 50 MVAr switchable line reactors at Vataman S/s end– 2 Nos. Switching equipment for 420 kV, 50 MVAr switchable line reactors at Vataman S/s end – 2 no</p>
5.	$\pm 300$ MVAr STATCOM at 220 kV level of Mahuva PS (GIS) with 1 No. of 220 kV bay	<ul style="list-style-type: none"> <li>• <math>\pm 300</math> MVAr STATCOM – 1 No.</li> <li>• 220 kV bay – 1 no.</li> </ul>
6.	420 kV, 1x125 MVAR Variable Bus Shunt Reactor with OLTC (control range between 50 – 125 MVAr for VSR) with 1 No. of 400 kV bay	<ul style="list-style-type: none"> <li>• 1x125 MVAR, 420kV Variable Bus Shunt Reactor with OLTC – 1 no.</li> <li>• 400kV Bus Reactor bay – 1 no.</li> </ul>
7.	245 kV, 3x50 MVAr Bus Reactors at 220 kV level of Mahuva PS (GIS)	<ul style="list-style-type: none"> <li>• 50 MVAR, 245kV Bus Reactor– 3 no.</li> <li>• 220kV Bus Reactor bay – 3 no.</li> </ul>

Sl. No.	Scope of the Transmission Scheme	Capacity /km
<b>A. Transmission System onwards Onshore Pooling Station</b>		
<b>B. Transmission System for integration of Offshore Wind Farms with Onshore PS</b>		
<b>Offshore Substation-1 {500 MW VGF}</b>		
1.	Establishment of 2x315 MVA, 220/66 kV Gujarat Offshore B3 Sub-Station Station-1 (B3-OSS-1) with 66 kV line bays – 10 Nos. for RE Interconnection	<ul style="list-style-type: none"> <li>• 220/66kV, 315 MVA, ICTs – 2 nos.</li> <li>• 220kV ICT bays – 2 nos.</li> <li>• 66kV ICT bays – 2 nos.</li> <li>• 220kV line bays – 2 nos. (at B3-OSS-1 for termination of B3-OSS-1 – Mahuva Onshore PS (GIS) 220 kV two nos. (3 core) cables)</li> <li>• 66kV line bays – 10 nos.</li> </ul>
2.	B3-OSS-1 – Mahuva Onshore PS (GIS) 220 kV two nos. (3 core) cables (45 km- under sea cable of about 35 km & under ground cable of about 10 km) alongwith associated line bays at both ends (with capacity of 300 MVA/ckt at nominal voltage) with 1x50 MVAr switchable line reactors at B3-OSS-1 end on each cable	<ul style="list-style-type: none"> <li>• Cable length ~45 km</li> <li>• 220 kV, 50MVAr switchable line reactors at OSS-1 end – 2 nos.</li> <li>• Switching equipment for 220 kV, 50 MVAr switchable line reactors at OSS-1 end – 2 nos.</li> </ul>

**Note:**

- TSP of Vataman S/s (Vataman Transmission Ltd.) shall provide space for augmentation works at Vataman S/s
- Vataman switching S/s has been planned through LILO of Lakadia-Vadodara 765 kV D/c line at Vataman under Khavda Ph-III (7 GW) and is presently under implementation by POWERGRID (under TBCB) with implementation schedule of Dec'25 (SCOD).
- Distances indicated above are tentative and may change based on actual survey.

**Implementation timeframe:** Mar-2028

**Estimated Cost:** Rs. About Rs 6900 Crs {Onshore Portion: 2200, Offshore Portion: 4700}

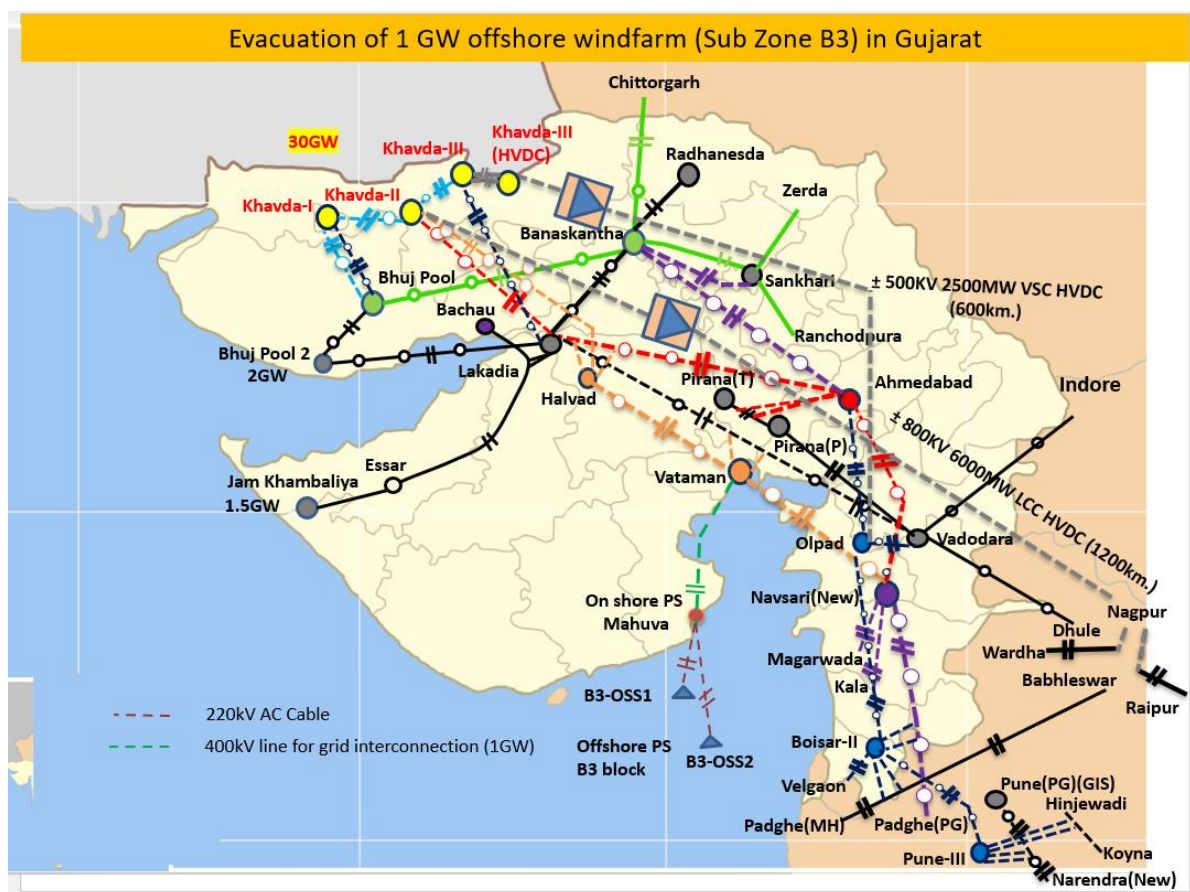

### 3.2 Maharashtra

#### (a) Network Expansion scheme in Western Region to cater to Pumped storage potential near Talegaon (Pune)

Hon’ble MoP, GOI has identified a potential of more than 10GW Pumped Storage Plants (PSPs) in the area between Boisar, Nashik & Pune. In this regard, application for Connectivity has been received from M/s Tata Power Company for Bhivpuri PSP of 1150MW with estimated commissioning date as 01.01.2028. M/s TPC is also planning PSP at Shirwata with 1980MW capacity.

Considering the huge PSP potential in the area, which are likely to tie up power for pumping mode from RE generation projects located far away, it was proposed to establish a 765/400 kV substation near South Kalamb. Further, considering huge demand of Mumbai area, space for HVDC terminal is proposed to be kept for future use.

Subsequently, applications for drawal of 1400MW power were received from Data Centre Loads in Mumbai area with start date of 01.01.2027. The applications are under process and Connectivity is being proposed at South Kalamb S/s to address the requirement of drawal of such huge quantum of power. The scheme was discussed and approved under TBCB in the 20<sup>th</sup> NCT meeting held on 25.06.2024 with implementation time frame of 24 months or 01.01.2027 (i.e., start date of GNA of DC loads), whichever is later. The detailed scope of work is given below:

#### Detailed scope of work:

Sl.	Scope of the Transmission Scheme	Capacity /km
-----	----------------------------------	--------------

No.		
1.	<p>Establishment 2x1500 MVA, 765/400 kV Substation near South of Kalamb with 2x330 MVAR, 765 kV bus reactor and 2x125 MVAR, 420 kV bus reactor.</p> <p><b><u>Future provision (space for):</u></b></p> <ul style="list-style-type: none"> <li>▪ 765/400 kV ICT along with bays- 10 Nos. (2 Nos. on Sec-I, 4 Nos. in Sec-II &amp; 4 Nos. on Sec-III)</li> <li>▪ 765 kV line bays along with switchable line reactors – 6 Nos. (4 Nos. on Sec-II &amp; 2 Nos. on Sec-III)</li> <li>▪ 765 kV Bus Reactor along with bay: 4 Nos. (2 Nos. on Sec-II &amp; 2 No. on Sec-III)</li> <li>▪ 765 kV Sectionalizer: 2 -sets</li> <li>▪ 400 kV line bays along with switchable line reactors– 20 Nos. (6 Nos. on Sec-I, 6 Nos. on Sec-II &amp; 8 Nos. on Sec-III)</li> <li>▪ 400/220 kV ICT along with bays -4 Nos. (on 400 kV Sec-III: 2 Nos. on 220 kV Sec-I &amp; 2 Nos. on 220 kV Sec-II)</li> <li>▪ 400 kV Bus Reactor along with bays: 4 Nos. (2 Nos. on Sec-II &amp; 2 No. on Sec-III)</li> <li>▪ 400 kV Sectionalization bay: 2- set</li> <li>▪ 220 kV line bays: 8 Nos. (4 Nos. on Sec-I &amp; 4 Nos. on Sec-II)</li> <li>▪ 220 kV Sectionalization bay: 1 set</li> <li>▪ 220 kV BC and TBC: 2 Nos.</li> <li>▪ Establishment of 6000 MW, ± 800 kV South Kalamb (HVDC) [LCC] terminal station (4x1500 MW) along with associated interconnections with 400 kV HVAC Switchyard (2x1500 MW on 400 kV Sec-I &amp; 2x1500 MW on 400 kV Sec-II) &amp; all associated equipment (incl. filters)/bus extension, etc.</li> </ul>	<ul style="list-style-type: none"> <li>• 765/400 kV, 1500 MVA ICT – 2 Nos. (7x500 MVA single phase units including one spare ICT Unit)</li> <li>• 765 kV ICT bays – 2 Nos.</li> <li>• 400 kV ICT bays – 2 Nos.</li> <li>• 765 kV Line bays – 4 Nos.</li> <li>• 330 MVA, 765 kV bus reactor- 2 Nos. (7x110 MVAR single phase Reactors including one spare Unit for bus /line reactor)</li> <li>• 765 kV Bus reactor bay – 2 Nos.</li> <li>• 125 MVA, 420 kV reactor- 2 Nos.</li> <li>• 400 kV Reactor bay- 2 Nos.</li> <li>• 400 kV line bays - 2 Nos. (for interconnection of PSP)</li> </ul>
2.	<p>LILO of Pune-III – Boisar-II 765 kV D/c line at South Kalamb S/s with associated bays at South Kalamb S/s</p>	<ul style="list-style-type: none"> <li>• LILO Route length: 40 km (160 ckm.)</li> <li>• The Pune-III – Boisar-II 765 kV D/c line is of Hexa Zebra configuration and LILO shall be of similar conductor configuration</li> </ul>
3.	<p>Installation of 1x240 MVA switchable line reactor on each ckt at South Kalamb end of Boisar-II – South Kalamb 765 kV D/c line (formed after above LILO)</p>	<ul style="list-style-type: none"> <li>• 1x240 MVA, 765 kV switchable line reactor – 2 Nos.</li> <li>• Switching equipment for 765 kV line reactor – 2 Nos.</li> <li>• Spare Reactor (1-ph, 1x80 MVA) unit at 765/400 kV South Kalamb S/s</li> </ul>

**Implementation time frame:** 24 months from the date of SPV transfer (or) 01.01.2027 whichever is earlier.

**Estimated Cost:** Rs. 1663 Crs.

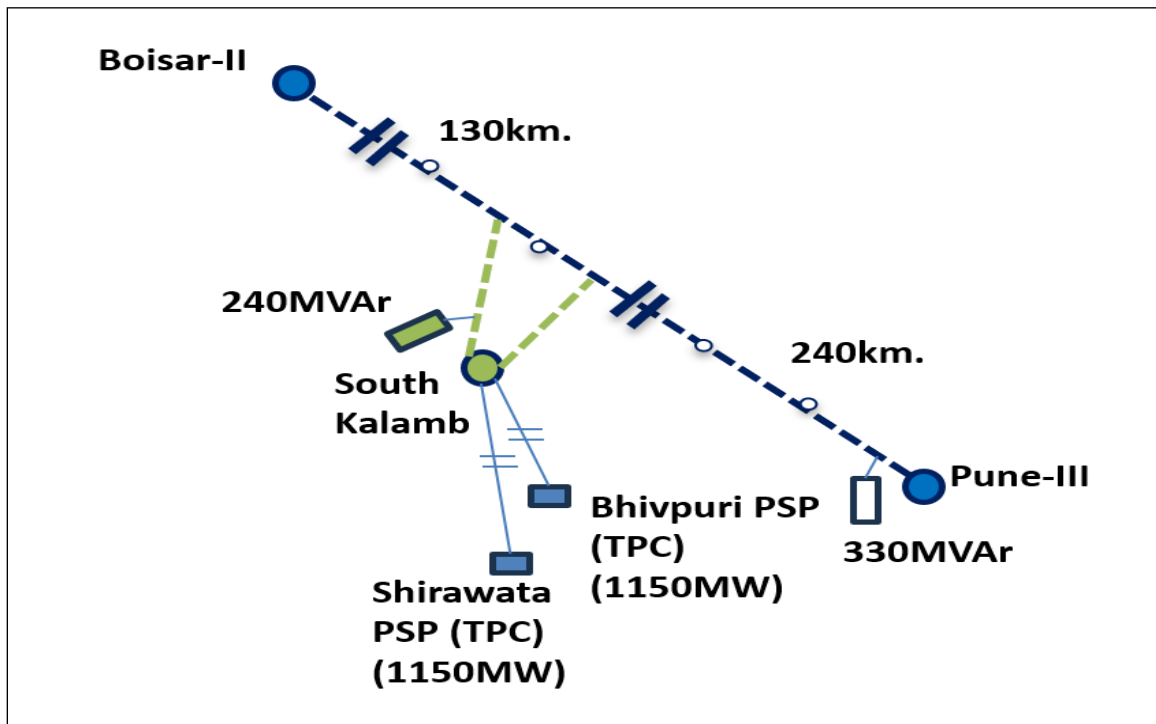

### 3.3 Madhya Pradesh

#### (a) Network Expansion Scheme in Vindhyachal complex of Madhya Pradesh

Connectivity application (No. 2200000400) by NTPC Ltd (1600 MW) was received in the month of Dec'23. After several round of deliberations, the transmission scheme for grant of connectivity under GNA to NTPC Ltd. for Singrauli-III 2x800MW units was finalised in 30<sup>th</sup> Consultation Meeting for Evolving Transmission Schemes in Western Region held on 02.07.2024 as per details given below:

#### Dedicated Transmission System for Connectivity

- Shifting of existing Vindhyachal V – Vindhyachal IV 400kV D/c (twin) line to Singrauli-III so as to form Vindhyachal V – Singrauli III 400kV D/c (twin) line. (Under scope of NTPC Ltd.)
- Installation of 1x125MVAR, 420kV Bus Reactor at Singrauli III 400kV Bus (Under scope of NTPC Ltd.)
- Vindhyachal IV – Vindhyachal PS 400kV 2<sup>nd</sup> D/c (quad) line (of CWRTL) shall be disconnected at Vindhyachal-IV and shall be shifted to Singrauli-III to form Singrauli III – Vindhyachal PS 400kV D/C (Quad) line. (Under scope of NTPC Ltd.)
- Singrauli III – Vindhyachal PS 400kV S/c (Quad) line (on S/c tower) (with minimum capacity of 2100MVA per ckt at nominal voltage). (Under scope of NTPC Ltd.) along with associated bay at Singrauli-III end. The line will be terminated in a 400kV bay at Vindhyachal PS which would be made available after bypassing works at Vindhyachal PS as mentioned under Common Transmission System Augmentation for grant of GNA

**Note:** Vindhyachal III – Vindhyachal V may be kept normally open and may be closed under contingency conditions based on feedback from GRID-INDIA.

**Common Transmission System Augmentation for grant of GNA: Under ISTS**

Sl. No.	Scope of the Transmission Scheme	Capacity /km
1.	Vindhyachal IV – Vindhyachal PS 400kV 1st D/c (quad) line (of POWERGRID) and Vindhyachal PS – Sasan 400kV D/c (twin) line (of POWERGRID) to be bypassed at Vindhyachal PS and interconnected with each other at outskirts of Vindhyachal PS (Under scope of ISTS) so as to form Vindhyachal IV (2x500MW) – Sasan 400kV D/c line.	NA

**Implementation time-frame:** 01.03.2028 (as per start date of connectivity requested by NTPC for Singrauli-III expansion project, for which above transmission system is required as Common Transmission System Augmentation for grant of connectivity under GNA)

**Note:**

1. This line will be exclusively used for 2x500MW Vindhyachal-IV evacuation.
2. With this arrangement, 4 nos. 400kV bays shall become available at Vindhyachal PS. Out of the same, 1 no. shall be utilized for termination of Singrauli III – Vindhyachal PS 400kV S/c (Quad) line of NTPC and balance 3 nos. bays may be utilized as per requirement in future.

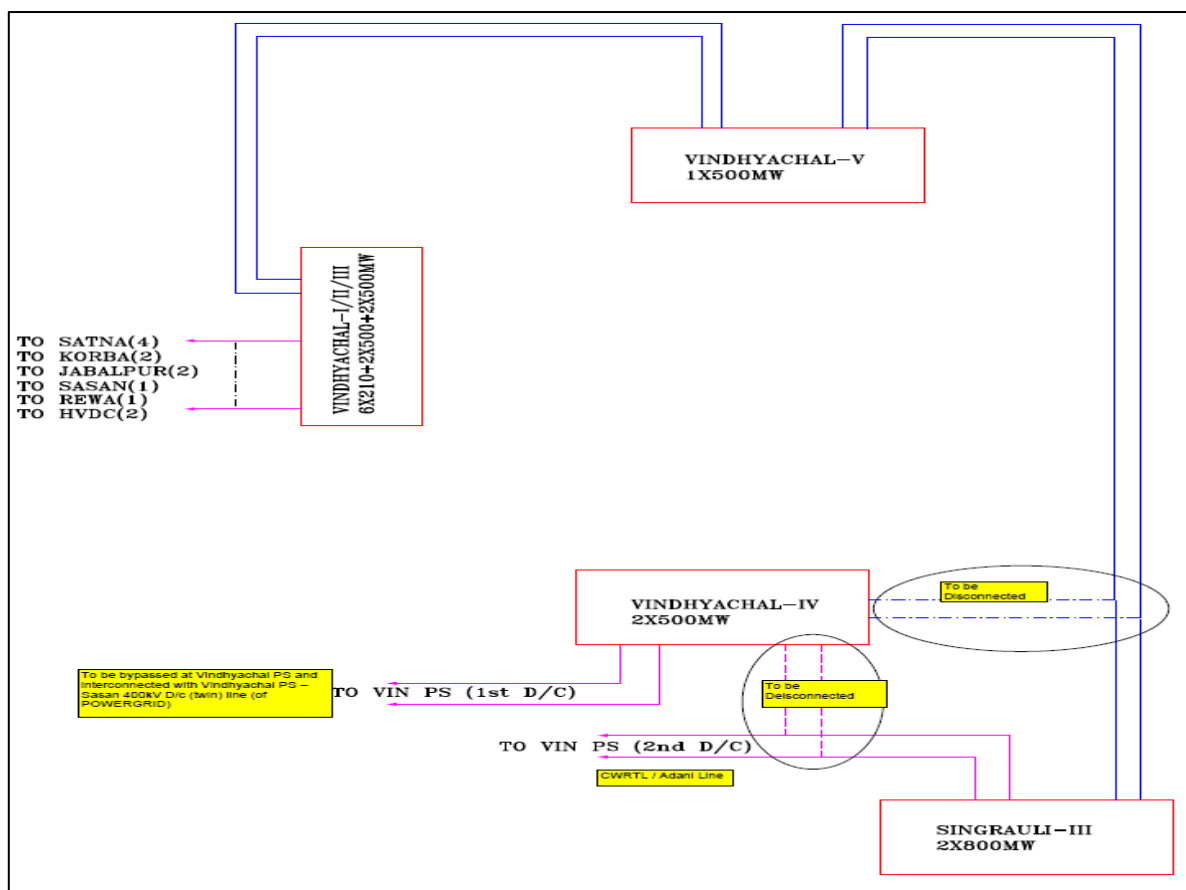

**(b) Transmission System for enabling RE interconnection at Mandsaur S/s**

765/400/220kV Mandsaur PS was planned with 3x1500MVA, 765/400kV & 5x500MVA, 400/220kV ICTs to enable evacuation of power from 2 GW Wind Potential. The scheme is currently under implementation by Mandsaur Transmission Limited (subsidiary of POWERGRID). M/s Sprng Green Energy 2 Pvt. Ltd. (SGE2PL) has applied for Connectivity at Mandsaur S/s vide application no. 2200000824 for 600MW RE power injection from 31.12.2029. The subject scheme is planned to enable the Connectivity of M/s INGEPL.

**Detailed scope of work:**

Sl. No.	Scope of the Transmission Scheme	Capacity /km
1.	1 No. 400kV bay at Mandsaur S/s for RE Interconnection (Sprng Green Energy 2 Pvt. Ltd. (SGE2PL) (2200000824) for 600MW)	400kV line bay – 1 No.

**Implementation time-frame:** 31.12.2029 as per start date of connectivity under GNA requested by applicant

**(c) Transmission System for enabling RE interconnection at Neemuch S/s**

2x500MVA, 400/220kV Neemuch S/s is an existing S/s of POWERGRID, which was planned to enable RE evacuation of up to 1GW in Neemuch area of MP., 2 nos. of 220kV bays were also implemented as a part of the pooling station were allotted to RUMSL’s Solar Park in Neemuch.

Subsequently, an application (No. 2200000709) for Connectivity for 300MW was received from M/s ACME Cleantech Solutions Pvt. Ltd. The subject scheme was planned to enable the injection of power from ACSPL’s 300MW Solar Park.

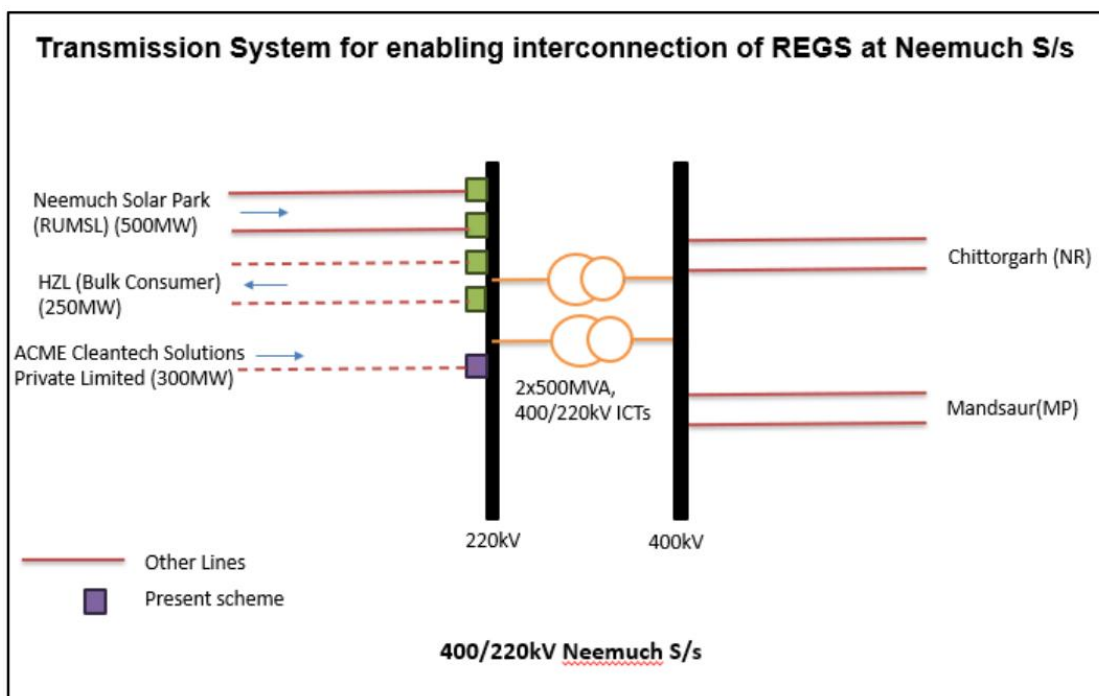

**Detailed scope of work:**

Sl. No.	Scope of the Transmission Scheme	Capacity /km
1.	1 No. 220kV bay at Neemuch S/s for RE Interconnection (ACME Cleantech Solutions Private Limited (2200000709) for 300MW)	220kV line bay – 1 No.

**Implementation time-frame:** 18 months or 31.12.2025 (as per start date requested by applicant), whichever is later

**Estimated cost:** Rs. 5.57 Crs.

**(d) Transmission system for Evacuation of Power from RE Projects in Neemuch (1000 MW) SEZ in Madhya Pradesh-Phase II**

The Government of India has set a target for establishing 500GW non-fossil generation capacity by 2030, out of which 1GW SEZ has been identified at Neemuch for which 2x500MVA, 400/220kV Neemuch PS is already commissioned by POWERGRID.

In view of applications received for cumulative capacity of 1770MW at Neemuch PS till Jun-24, it was found prudent to expand the substation to its full capacity so as to accommodate applications being received beyond 1GW at Pachora PS. Accordingly, the present scheme is planned which shall enable evacuation of additional 1000MW power from RE projects in Neemuch SEZ (i.e. 1000 MW beyond 1000MW) in Madhya Pradesh. The scheme was agreed in the 31<sup>st</sup> CMTS-WR held on 02.08.2024 and is currently under approval. The detailed scope of work is given below.

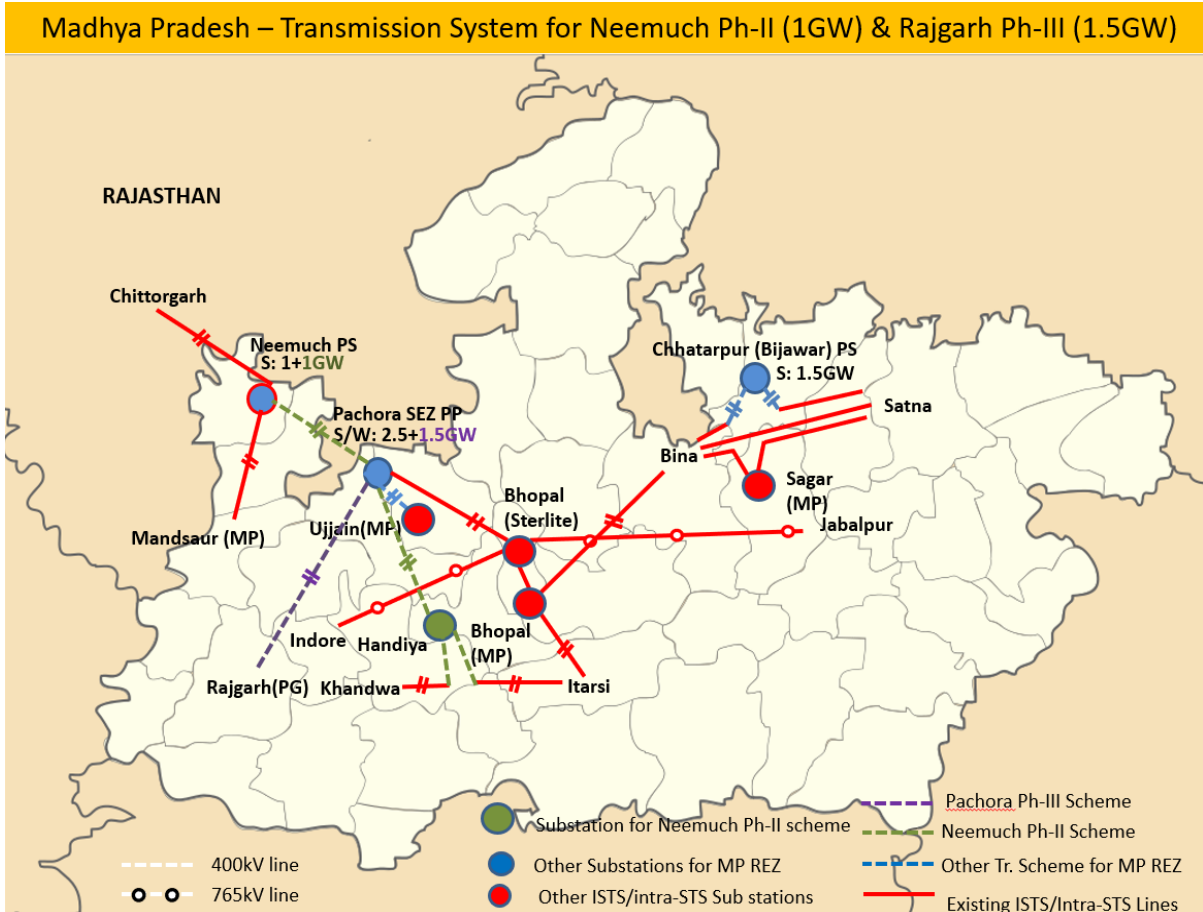

**Detailed scope of work:**

Sl. No.	Scope of the Transmission Scheme	Capacity
1.	Creation of New 220kV Bus Section-II at Neemuch PS with Augmentation of transformation capacity by 3x500MVA, 400/220kV ICTs (3 <sup>rd</sup> , 4 <sup>th</sup> & 5 <sup>th</sup> ) at Neemuch S/s along with associated bays.	<ul style="list-style-type: none"> <li>• 500MVA 400/220kV ICT – 3 No.</li> <li>• 400kV ICT bay – 3 No.</li> <li>• 220kV ICT bay – 3 No. (on Sec-II)</li> <li>• 220kV Bus Sectionaliser bays – 1 set</li> <li>• 220kV BC &amp; TBC – 1 No. each</li> </ul>
2.	4 Nos. 220kV Line bays at Neemuch PS for RE interconnection	220kV Bays – 4 Nos. on Sec-II
3.	Neemuch PS – Pachora PS 400kV D/c line (Quad ACSR/ AAAC/ AL59 Moose equivalent) along with 50MVAr Sw LR on each ckt at both ends	<ul style="list-style-type: none"> <li>• Line length: 190km.</li> <li>• 400kV bays: 4 nos. (2 at Neemuch PS &amp; 2 at Pachora PS)</li> <li>• 420kV, Sw LRs: 4 nos. (2 at Neemuch PS &amp; 2 at Pachora PS)</li> <li>• Switching equipment for 400 kV line reactor – 4 Nos. (2 at Neemuch PS &amp; 2 at Pachora PS)</li> </ul>

Sl. No.	Scope of the Transmission Scheme	Capacity
4.	<p>Establishment of 2x500MVA, 400/220kV S/s at Handiya with 2x125MVA 420kV Bus Reactors</p> <p><b>Future provision (space for):</b></p> <ul style="list-style-type: none"> <li>• 400 kV line bays along with switchable line reactors – 6 Nos. (Sec-II)</li> <li>• 400/220 kV ICT along with bays - 4 Nos. (1 No. on Sec-I &amp; 3 Nos. on Sec-II)</li> <li>• 400 kV Bus Reactor along with bays: 2 Nos. (Sec-II)</li> <li>• 220 kV line bays: 8 No. (on Sec-II)</li> <li>• 400 kV Sectionalization bay: 1 set</li> <li>• 220 kV Sectionalization bay: 1 set</li> <li>• 220 kV TBC &amp; BC: 1 No.</li> </ul>	<ul style="list-style-type: none"> <li>• 400/220kV ICTs: 2 Nos.</li> <li>• 400kV ICT Bays: 2 Nos.</li> <li>• 220kV ICT Bays: 2 Nos.</li> <li>• 400kV Line bays: 6 Nos.</li> <li>• 220 kV line bays for MPPTCL – 8 Nos.</li> <li>• 125 MVA, 420 kV Bus reactor – 2 Nos</li> <li>• 400 kV Bus reactor bay: 2 Nos.</li> <li>• 220 kV TBC bay – 1 no.</li> <li>• 220 kV BC bay – 1 no.</li> </ul>
5.	<p>Pachora PS – Handiya 400kV D/c line (Quad ACSR/AAAC/ AL59 Moose equivalent) along with associated bays at Pachora PS end and 50MVA Sw LR on each ckt at both ends</p>	<ul style="list-style-type: none"> <li>• Line length: 190km.</li> <li>• 400kV bays: 2 nos. (at Pachora PS)</li> <li>• 420kV, Sw LRs: 4 nos. (2 at Handiya &amp; 2 at Pachora PS)</li> <li>• Switching equipment for 400 kV line reactor – 4 Nos. (2 at Handiya &amp; 2 at Pachora PS)</li> </ul>
6.	<p>LILO of Khandwa (PG) – Itarsi (PG) 400kV D/c (Twin Moose) line at Handiya S/s</p>	<ul style="list-style-type: none"> <li>• LILO route length: 22 km (88 ckm)</li> <li>• The Khandwa (PG) – Itarsi (PG) 400kV D/c line is of Twin Moose configuration and LILO shall be of similar conductor configuration</li> </ul>
7.	<p>Installation of 1x125 MVAR, 420 kV bus reactor (2<sup>nd</sup>) at Neemuch PS</p>	<ul style="list-style-type: none"> <li>• 125 MVA, 420 kV Bus reactor – 1 No.</li> <li>• 400 kV Bus reactor bay: 1 No.</li> </ul>

**Note:** TSP of Neemuch & Pachora PS shall provide space for above scope of work

**Implementation time-frame:** 24 months from the date of SPV transfer.

**Estimated cost:** Rs. 2240 Crs.

**(e) Transmission system for Evacuation of Power from RE Projects in Rajgarh (1500 MW) SEZ in Madhya Pradesh-Phase III**

The Government of India has set a target for establishing 500GW non-fossil generation capacity by 2030, out of which 2.5GW REZ potential has been identified at Rajgarh (MP). Transmission schemes for evacuation of the identified 2.5GW RE power were planned in two phases as detailed below.

- I. Phase-I (1.5GW) involves establishment of Pachora PS with 3x500 MVA 400/220kV ICTs and Pachora PS – Bhopal 400kV D/c line which was implemented by M/s G R Infraprojects Ltd.
- II. Phase-II (1GW) involves ICT augmentation (4th, 5th & 6th) Pachora PS along with Pachora PS – Ujjan (MPPTCL) 400kV D/c line which is presently under implementation by M/s G R Infraprojects Ltd. with SCOD of 14.02.2026.

However, in view of applications received for cumulative capacity of 3813MW at Pachora PS till Jun-24, it is prudent to expand the substation to its full capacity so as to accommodate applications being received beyond 2.5GW at Pachora PS.

Accordingly, the present scheme is planned which shall enable evacuation of additional 1500MW power from RE projects in Rajgarh SEZ (i.e. 1500 MW beyond 2500MW) in Madhya Pradesh. The scheme was agreed in the 31<sup>st</sup> CMTS-WR held on 02.08.2024 and is currently under approval. The detailed scope of work is given below.

**Detailed scope of work:**

Sl. No.	Scope of the Transmission Scheme	Capacity
1.	Creation of New 220kV Bus Section (3 <sup>rd</sup> ) with 220kV Bus Sectionalizer and 400/220kV, 3x500MVA ICT augmentation (7 <sup>th</sup> , 8 <sup>th</sup> & 9 <sup>th</sup> ) at Pachora PS terminated on 220kV Bus Section (3 <sup>rd</sup> )	<ul style="list-style-type: none"> <li>• 500MVA 400/220kV ICT – 3 No.</li> <li>• 400kV ICT bay – 3 No.</li> <li>• 220kV ICT bay – 3 No. (on Sec-III)</li> <li>• 220kV Bus Sectionalizer bays – 1 set</li> <li>• 220kV BC &amp; TBC – 1 No. each</li> </ul>
2.	4 nos. 220kV line bays for RE Interconnection on Bus Section (3 <sup>rd</sup> )	<ul style="list-style-type: none"> <li>• 4 Nos. on Sec-III</li> </ul>
3.	Pachora PS – Rajgarh(PG) 400 kV D/c line (Quad ACSR/ AAAC/ AL59 Moose equivalent) along with associated bays at both ends (180km.) and 50MVAR Sw LR on each ckt at both ends	<ul style="list-style-type: none"> <li>• Line length: 180km.</li> <li>• 400kV bays: 4 nos. (2 at Rajgarh (PG) &amp; 2 at Pachora PS)</li> <li>• 420kV, Sw LRs: 4 nos. (2 at Rajgarh (PG) &amp; 2 at Pachora PS)</li> <li>• Switching equipment for 400 kV line reactor – 4 Nos. (2 at Rajgarh (PG) &amp; 2 at Pachora PS)</li> </ul>
4.	Installation of 1x125 MVAR, 420 kV bus reactor at Pachora PS (400kV Bus Section-II)	<ul style="list-style-type: none"> <li>• 125 MVAR, 420 kV Bus reactor – 1 No.</li> <li>• 400 kV Bus reactor bay: 1 No.</li> </ul>

**Note:** TSP of Neemuch & Pachora PS shall provide space for above scope of work

**Implementation time-frame:** 24 months from the date of SPV transfer.

**Estimated cost:** Rs. 1079 Crs.

**(f) Transmission System for evacuation of power from Mahan Energen Limited Generating Station in Madhya Pradesh**

2x600MW Thermal Power Station of M/s Mahan Energen Limited (MEL) located in Singrauli, Madhya Pradesh is already connected with ISTS. M/s MEL was granted Connectivity for 1100MW under the CERC Connectivity/ LTA Regulations, 2009 and power was being evacuated through implementation of SPS. Subsequently, M/s MEL has applied for Connectivity for remaining 100MW vide application no. 2200000224.

To evacuate the total 1200MW capacity of power reliably without SPS, the “Transmission System for evacuation of power from Mahan Energen Limited Generating Station in Madhya Pradesh” is proposed with the scope of work as detailed below. The scheme was deliberated and agreed in the WRPC meeting

held on 27.03.2024 with an implementation timeframe of 30 months. Subsequently, the scheme was approved in the 20<sup>th</sup> NCT meeting held on 25.06.2024 and was recommended for implementation under TBCB.

**Detailed scope of work:**

Sl. No.	Scope of the Transmission Scheme	Capacity /km
1.	Mahan (existing bus) – Rewa PS (PG) 400 kV D/c (Quad ACSR/AAAC/AL59 moose equivalent)line	Route Length: ~110 km.
2.	2 Nos. 400 kV bays at Rewa PS (PG) for termination of Mahan (existing bus) – Rewa PS (PG) 400 kV D/c line (Quad ACSR/AAAC/AL59 moose equivalent)line	400 kV bays: 2 Nos.

**Note:**

- 2 Nos. 400 kV line bays at MEL (existing) shall be under the scope of MEL.
- POWERGRID to provide space at Rewa PS (PG) for scope at Sl. 2.

**Implementation timeframe:** 30 months from the date of SPV transfer.

**Estimated Cost:** Rs. 558 Crs. (Approx.)

**Transmission System for evacuation of power from Mahan Energen Limited Generating Station in Madhya Pradesh**

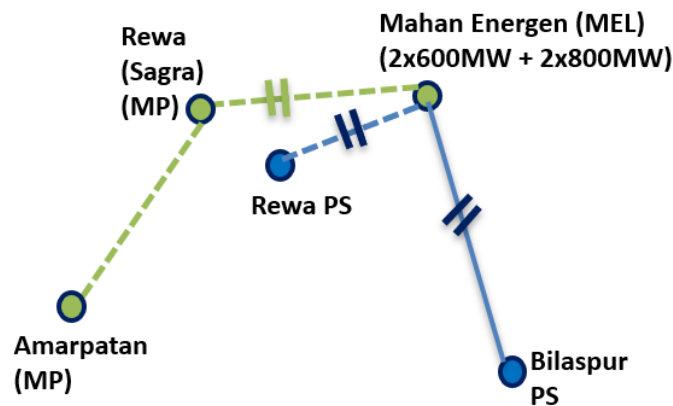

**Figure:** Transmission scheme for evacuation of power from 1200MW Mahan TPS & 1600MW Mahan extension plant.

**3.4 Chhattisgarh**

**(a) Transmission System for evacuation of power from Vedanta’s Thermal Power Station (1200MW) in Sakti, Chhattisgarh**

M/s Vedanta applied for Connectivity for 1200MW at Raigarh (Kotra) S/s for Athena 2x600MW Power Project. However, there is no margin for injection left at Raigarh(Kotra) Substation for injection of power as any injection at Raigarh(Kotra) S/s leads to N-1 non-compliance of 765/400kV ICTs

[especially under Raigarh-Pugalur HVDC reverse power flow scenario (3000MW reversal)] and there are severe fault level issues at the substation.

In view of the same, connectivity has been agreed at Raigarh(PG) S/s. However, as there is no space left at Raigarh(PG) S/s for 2 nos. 400kV bays, it was agreed that Vedanta shall connect to Raigarh(PG) S/s by interconnecting the already existing 400kV D/c line upto Raigarh(Kotra) with Raigarh (Kotra) – Raigarh (PG) 400kV D/c line (which is presently kept normally open to control fault level at Raigarh (Kotra) & Raigarh(PG) substations).

Considering that the 400kV bays at Raigarh (PG) are rated at 2000A (i.e. 1385MVA), they shall be sufficient to cater to 1200MW capacity of Vedanta’s Athena project, without the need for upgradation. However, since Raigarh (Kotra) – Raigarh (PG) 400kV D/c line is twin moose line, a portion of it which would be utilized by M/s Vedanta would need to be reconducted to meet the evacuation requirement of 1200MW capacity (matching with capacity of Vedanta’s Athena project). Based on feedback from M/s Vedanta regarding the feasibility of implementation, the scheme was planned with the following scope of work.

**Detailed scope of work:**

Sl. No.	Scope of the Transmission Scheme	Capacity /km
1.	Reconductoring of a portion of Raigarh (Kotra) – Raigarh (PG) 400kV D/c line [i.e. from Raigarh(PG) to Termination point near Raigarh(PG) at which Vedanta’s 400kV D/c line is being terminated into Raigarh (Kotra) – Raigarh (PG) 400kV D/c line so as to form Vedanta – Raigarh(PG) 400kV D/c line]* with twin HTLS conductor (with minimum capacity of 1200MW per ckt at nominal voltage (~1.3km.))	1.3km. reconductoring
2.	Associated jumpering arrangement at termination point so as to establish Vedanta – Raigarh(PG) 400kV D/c line (with minimum capacity of 1200MW per ckt at nominal voltage)	-

**Implementation time-frame:** 6 months from award to implementing agency

**Estimated cost:** Rs. 3.61 Crs.

**(b) 400kV line bays at Champa for Interconnection of NTPC LARA STPP STAGE-II (1600MW) Project**

6x1500MVA, 765/400kV Champa PS is an existing substation of POWERGRID with 3x1500MVA, 765/400kV ICTs on each bus section.

Lara stage-I STPP (2x800 MW) of NTPC was granted connectivity through Lara STPP I – Raigarh (Kotra) PS 400kV D/c line and Long Term Access (LTA) through Lara STPP I – Champa PS (Section-I) 400kV D/c (quad) line for transfer of 1500MW power from the Lara-I project to various beneficiaries in WR. The entire 1500MW quantum has now been converted into deemed GNA. KSK 3x600MW units are connected at Champa PS on the 400kV Bus Section-II.

Application for Connectivity for 1600MW was received from NTPC for LARA STPP STAGE-II Project (2x800MW) which was allowed for injection of power from the 400kV Bus Section-II of Champa PS (where KSK 3x600MW Units are connected). The present scheme involves 2 nos. 400kV bays at Champa PS (Bus Section B, with KSK 3x600MW Units) for termination of 400kV D/c (Quad) line from Lara STPP St-II generation switchyard to Champa PS.

**Detailed scope of work:**

Sl. No.	Scope of the Transmission Scheme	Capacity /km
1.	2 nos. 400kV bays at Champa PS (Bus Section A, with KSK 3x600MW Units) for termination of Lara STPP St-II Generation Switchyard – Champa 400kV D/c (Quad) line	400kV line bays: 2 Nos. (on Bus Section A, with KSK 3x600MW Units)

**Implementation time-frame:** 01.05.2027 (as per start date of connectivity requested by NTPC Ltd.)

**Estimated cost:** Rs. 18.57 Crs.

**(c) Scheme to control high voltages at Champa PS (on Bus Section-A, where Lara-I project is connected)**

6x1500MVA, 765/400kV Champa PS is an existing substation of POWERGRID with 3x1500MVA, 765/400kV ICTs on each bus section. During the deliberations made in the 29<sup>th</sup> CMETS-WR held on 03.06.2024, GRID-INDIA has put forth the observation of high voltages on the bus section-I of both 765kV & 400kV buses of Champa PS after bus sectionalisation due to inadequate shunt reactive power compensation.

As a result of this, Champa-Kurukshetra HVDC bipole-I is also being blocked for controlling the voltages during off-peak hours. Hence there is a requirement of sufficient reactive power compensation at Champa PS on Section-I of 765kV & 400kV buses (where Lara-I is connected) for reliable operation of Champa-Kurukshetra HVDC bipoles.

**Detailed scope of work:**

Sl. No.	Scope of the Transmission Scheme	Capacity
1.	Installation of 1x240MVA <sub>r</sub> , 765kV Bus Reactor & 1x125MVA <sub>r</sub> , 420kV Bus Reactor at Champa PS ( <i>On Bus section-A where Lara-I project is connected</i> )	<ul style="list-style-type: none"> <li>• 1x240MVA<sub>r</sub>, 765kV Bus Reactor – 1 No.</li> <li>• 765kV BR bay – 1 No.</li> <li>• 1x125MVA<sub>r</sub>, 420kV Bus Reactor – 1 No.</li> <li>• 400kV BR bay – 1 No.</li> </ul>

**Note:** TSP of Champa PS shall provide space for above work.

**Implementation time-frame:** 18 months

**Estimated cost:** Rs. 79.28 Crs.

**(d) Associated Transmission System for grant of Connectivity under GNA to Sipat STPS Stage-III (1x800MW)**

The existing 2x1000MVA, 765/400kV ICTs at Sipat STPS are seen to be overloaded in system studies in Solar Max Scenario even under reduced generation at Sipat STPS. Hence, Augmentation of transformation capacity at Sipat STPS by 1x1500MVA, 765/400kV ICT (3<sup>rd</sup>) shall be required to alleviate the constraint. NTPC has applied for Connectivity at NTPC Sipat for injecting 800MW thermal power. The same was deliberated in the 30<sup>th</sup> CMETS-WR and it was agreed for augmentation of transformation capacity at Sipat STPS with the following scope of work subject to feasibility of Augmentation

**Detailed scope of work:**

Sl. No.	Scope of the Transmission Scheme	Capacity
1.	Augmentation of transformation capacity at Sipat STPS by 1x1500MVA, 765/400kV ICT (3rd)	1500MVA, 765/400kV ICT-1 No. (4x500MVA Incl. spare)  765kV ICT Bay: 1 No.  400kV ICT Bay: 1 No.

**Note:**

- NTPC to provide space for above works
- The ICT is to be placed at 765kV Bus Section-II by utilising bay no. 23 at 765kV side and Bay no. 21 on 400kV side. For both these bays, tie bay is existing and Main bay is to be constructed. Further, Connection of 400kV side of ICT-3 with associated 400kV bay requires crossing under 765kV Sipat-Bilaspur-1, 2 and 3 lines through BPIs at 8m equipment height or suitable gantry arrangement.

**Implementation timeframe: 31.01.2028**

#### 4. ISTS Network Expansion Scheme in Northern Region

##### 4.1 Rajasthan

##### (a) Augmentation of 400/220 kV, 1x500 MVA (4th) ICT at Bassi (PG) S/s

In 28<sup>th</sup> CMETS-NR meeting held on 27/03/24, it was stated that at present, 400/220kV Bassi Substation has 2x315+1x500MVA ICTs thus makes total transformation capacity of 1130MVA. POWERGRID in 203<sup>rd</sup> OCC stated that the loading at ICTs at Bassi is more than 900MW resulting in non-compliance of N-1 Contingency.

From the loading pattern of Bassi ICTs (2x315+1x500) of past one year, it is observed that cumulative maximum loading on 400/220 kV ICTs is about 1100 MW and loading is higher (>850MW) in winter season (Oct'23-Jan'24) for sufficient duration of time. From the analysis, it emerged that loading is breaching N-1 limit for peak Loading of ICTs (total 855 MW on 3 nos. ICTs). Further in CTU planning file for 2026-27 timeframe, ICT loadings are higher (312MW in N-1 Contingency) and may breach the N-1 limit.

As per deliberation held in 213<sup>th</sup> OCC meeting, with planned a LILO of 220kV Dausa-Sawai Madhopur line at Jaipur South S/s, loading of Bassi ICT is relived marginally (30MW/ICT in N-1 contingency), however 400/220 kV ICTs will still be non-compliant in future.

POWERGRID vide mail dated 22.02.24 confirmed space availability for Augmentation of 400/220kV transformer (4th,1x500MVA) along with transformer bays at 400/220kV Bassi (PG) S/s.

In the meeting, Grid-India stated that at Bassi there is urgent requirement of augmentation of 400/220kV ICT as ICTs were N-1 non-compliant in current winter season. RVPN stated that at present total 6 nos. 220kV feeders are connected to Bassi substation with peak drawl requirement of 1200-1300MW and as per loading pattern, loading is already breaching N-1 limit. Further, with Hindaun ICT and LILO of 220kV Dausa-Sawai Madhopur line at Jaipur South, ICT loading at Bassi may reduce to only some extent. RVPN further stated that considering future drawl requirement at Bassi S/s, ICT augmentation at Bassi may be considered.

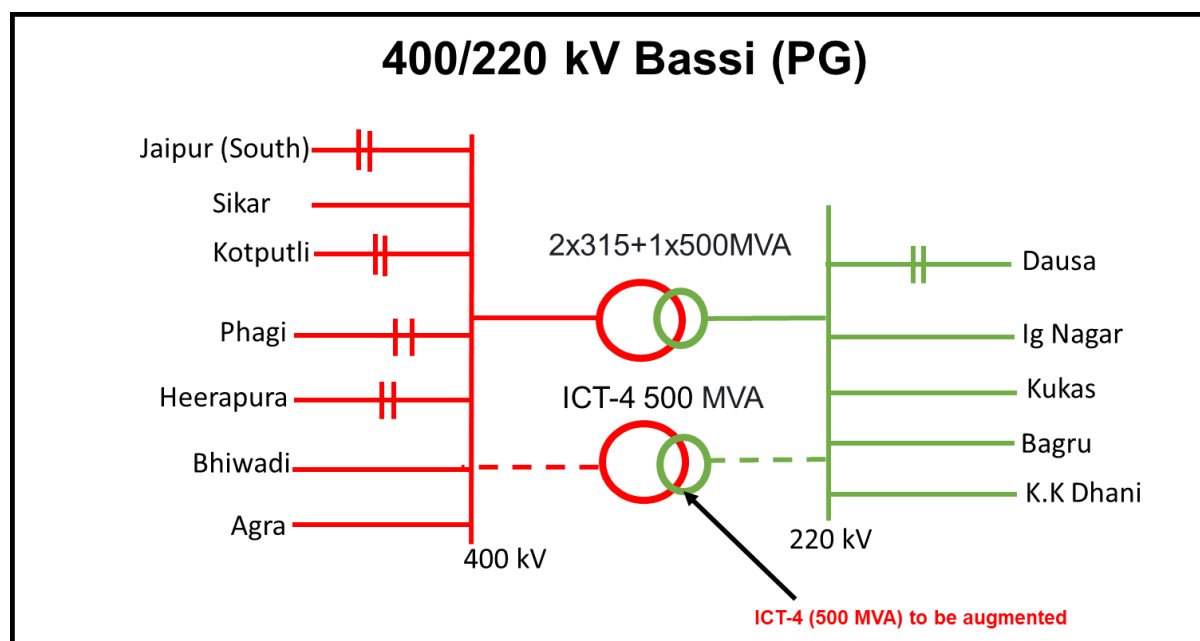

Figure : Schematic of 400/220 kV Bassi (PG) S/s

The scheme is under implementation with following details:

**Project Name** - Augmentation of Transformation Capacity at 400/220 kV Bassi (PG) S/s in Rajasthan by 400/220 kV, 1x500 MVA ICT (4th )

Sl. No.	Scope of the Transmission Scheme	Capacity/km	Implementation timeframe
1	Augmentation of Transformation Capacity at 400/220 kV Bassi (PG) S/s in Rajasthan by 400/220 kV, 1x500 MVA ICT (4th) along with associated transformer bays	500 MVA, 400/220 kV ICT- 1 no. 400 kV ICT bay – 1 no. 220 kV ICT bay – 1 no.	18 months from the date of issuance of CTUIL OM i.e. 14.12.2025
<b>Total Estimated Cost:</b>			<b>INR 49.87 Cr</b>

This scheme was awarded to POWERGRID through RTM mode vide CTU OM dated 14.06.2024 with an implementation time frame of 18 months i.e. anticipated by 14.12.2025.

**(b) Augmentation with 500 MVA (4th) ICT at 400/220 kV Bhiwadi (Hybrid) substation**

It was stated that in 28th CMETS-NR meeting held on 27.03.24, agenda for augmentation of 400/220kV ICT at Bhiwadi Substation was deliberated. In the meeting it was discussed that from the loading pattern of Bhiwadi ICTs (3x315 MVA) , it is observed that cumulative maximum loading on 400/220 kV ICTs is about 820 MW and loading is higher (>600MW) in Jun-Sep’23 & Jan’24-Feb’24 for sufficient duration of time. From the analysis, it emerged that loading is breaching N-1 limit for peak Loading of ICTs (800 MW). Further in CTU planning file, ICT loadings are higher (2x310 MW in case of N-1 Contingency) and may breach the N-1 limit.

POWERGRID vide mail dated 23.02.24 confirmed space availability for Augmentation of 400/220kV transformer (4th,1x500MVA) along with transformer bays at 400/220kV Bhiwadi (PG) S/s. However, 220kV Side of ICT is required to be routed through cable.

In the 29<sup>th</sup> CMETS-NR held on 17.05.24, Grid-India stated that at Bhiwadi transformer loading are close to N-1 limit and in view of that requirements may be assessed based on future load growth in Bhiwadi complex considering planned interconnections by RVPN/HVPN in future. RVPN stated that at present for Rajasthan, 4 nos. of 220kV feeders are interconnected at Bhiwadi substation and no new interconnection is planned for drawl in future. RVPN also stated that a new 400/220kV substation near Bhiwadi is recently approved by RVPN board to cater future drawl requirement at Bhiwadi complex in view of anticipated load growth. In reply to implementation timeframe of proposed new substation in Bhiwadi, RVPN stated that implementation may take minimum 3 years from now.

POWERGRID stated that loading at Bhiwadi substation are critical and N-1 noncompliant in peak load condition. Further, 2 nos. of 400/220kV ICTs (make 2003 year) already completed 21 years of life and gases are observed to be high due to loading of ICTs. Considering above ICT augmentation is required

at Bhiwadi substation. CTU stated that ICT loadings are close to N-1 limit, however HVPN/RVPN need to concur on requirements of ICT augmentation. CTU stated that decision of ICT augmentation may be expedited as Implementation of 400/220kV ICT may take 18-21 months from award and ICT may be available by mid of 2026 only.

CTU enquired RVPN and HVPN to update on the requirement of Augmentation of 400/220kV transformer (4th, 1x500MVA) at Bhiwadi S/s based on their assessment.

RVPN stated that power flow over all the existing drawl feeders from Bhiwadi (PG) is already saturated and to meet the future load of Bhiwadi area, other scheme is being planned. RVPN also stated that 220kV Bhiwadi(PG)-Neemrana (RVPN) is being LILoed at Neemrana (PG) and with above LILo part load (~50-70MW) will be shifted from Bhiwadi(PG) to Neemrana(PG) and RVPN may not drawl additional power from existing feeders of Bhiwadi(PG) S/s.

HVPN stated that at present no additional drawl requirement is envisaged in future from Bhiwadi (PG) S/s. However for N-1 compliance, HVPN concurred for Augmentation of 400/220 kV, 500 MVA (4th) ICT at Bhiwadi S/s and same was informed vide HVPN letter dated 17.05.24.. HVPN also stated that they are planning some ICT augmentation at 220kV intra state network, however it will not impact 400/220kV ICT loading much.

Grid-India suggested that as N-1 noncompliance occurs for short duration of time, replacement of 315MVA ICT with 500MVA ICT may be considered in place of augmentation with 4th ICT at Bhiwadi S/s. POWERGRID stated that even with load diversion (~50-70MW), ICT loadings are close to N-1 limits and considering type of load (critical) as well as with increasing gases trend in existing ICTs, ICT augmentation may be considered. POWERGRID stated that 2nos. of ICTs at Bhiwadi S/s requires continuous inspection & degassing due to high loading of ICTs and they are not able to get shutdown of ICTs from RVPN side due to continuous load demand in Bhiwadi complex and with long outage of ICTs, load will also be impacted.

RVPN stated that in long outage condition of ICTs, there will be severe issues in serving the critical load of Bhiwadi complex which is mainly industrial load and replacement of ICT may also require shutdown. RVPN stated that in view of issues in existing 400/220kV ICTs, frequent shutdown requirement and possible long outages of above ICTs which will impact critical industrial loads in Bhiwadi area , augmentation with 4th ICT may be considered at Bhiwadi substation . HVPN also concurred on the same.

Grid-India stated that as RVPN and HVPN concurred for ICT augmentation requirement to meet N-1 compliance, same is agreeable to them instead of replacement of ICT.

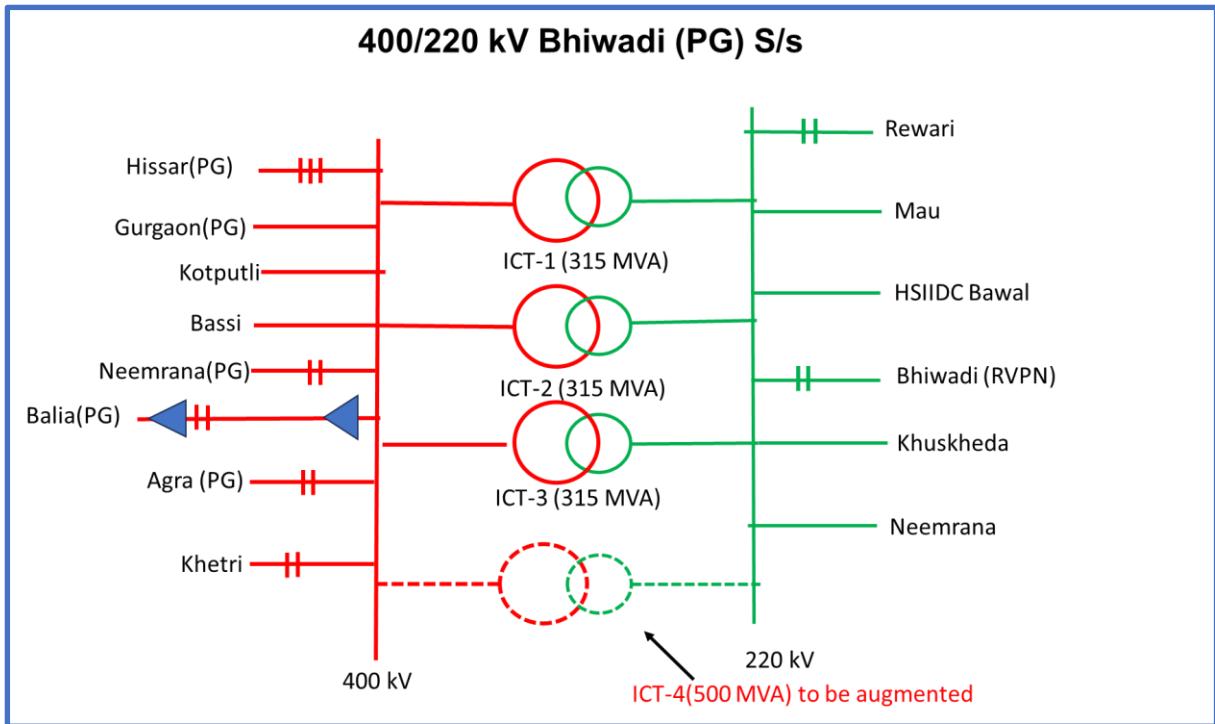

Figure : Schematic of 400/220 kV Bhiwadi (PG) S/s

The scheme is under implementation with following details:

**Project Name** - Augmentation of Transformation Capacity at 400/220 kV Bhiwadi (PG) S/s in Rajasthan by 400/220 kV, 1x500 MVA ICT (4th )

Sl. No.	Scope of the Transmission Scheme	Capacity/km	Implementation timeframe
1	Augmentation of Transformation Capacity at 400/220 kV Bhiwadi (PG) S/s in Rajasthan by 400/220 kV, 1x500 MVA ICT (4th ) along with associated transformer bays.	<ul style="list-style-type: none"> <li>➤ 500 MVA, 400/220 kV ICT- 1 no.</li> <li>➤ 400 kV ICT bay – 1 no.</li> <li>➤ 220 kV ICT bay – 1 no</li> <li>➤ 220kV Cable (1 ph)– 3200mtr (4x800mtr) (approx.)</li> <li>➤ 220 kV Cable Termination Kit : 8 nos..</li> </ul>	18 months from the date of issuance of CTUIL OM i.e. 18.01.2026
<b>Total Estimated Cost:</b>			<b>INR 65.25 Cr</b>

This scheme was awarded to POWERGRID through RTM mode vide CTU OM dated 18.07.2024 with an implementation time frame of 18 months i.e. anticipated by 18.01.2026.

**(c) Augmentation with 400/220 kV 1x500 MVA(9th) ICT at Bikaner-II to meet N-1 compliance**

In the 29<sup>th</sup> CMETS-NR meeting held on 17/05/24 It was stated that 400/220 kV Bikaner-II PS is an existing RE pooling station with transformation capacity of 1000 MVA(2x500MVA). Further, 6 no. of

500 MVA 400/220kV, ICTs are under implementation with the schedule progressively from Jun'24 upto Jan'25. Therefore, considering above total transformation capacity at 400/220 kV Bikaner-II PS shall be 4000MVA (8x500MVA) by Jan'25. Considering the total connectivity of 3785 MW granted at 220 kV level at Bikaner-II PS, augmentation of 1x500 MVA, 400/220kV (9th) ICT at Bikaner-II PS shall be required to meet N-1 compliance.

Grid-India (NRLDC) enquired about bus splitting arrangement at 220kV level of Bikaner-II PS. CTUIL stated that there is bus sectionalizer arrangement (normally closed) as per present practise. Grid-India stated that in some of RE pooling stations there are 2 or 3 different 220kV sections with n-1 compliance (400/220kV ICT) in each section. CTU stated that in some pooling stations i.e. Fatehgarh-II PS, Bhadla-II PS where 220kV bus sections are geographically isolated (way apart from each other), accordingly there is no sectionalizer arrangement feasible in two sections and n-1 compliance of 400/220kV ICTs to be ensured in both the sections as per planning criteria. CTU also stated that different configuration of 220kV section arrangement i.e. 220kV isolated sections in two different directions or 220kV common bus with sectionalizer arrangement (normally closed) is only decided by the TSP based on GA and layout of substation. Based on above n-1 compliance (400/220kV ICT) requirement will be identified. At Bikaner-II PS there is common 220kV bus with bus sectionalizer arrangement which would be normally in closed position, therefore N-1 compliance is being considered on common 220kV bus. Grid-India stated that some common philosophy should be adopted for Grid operation.

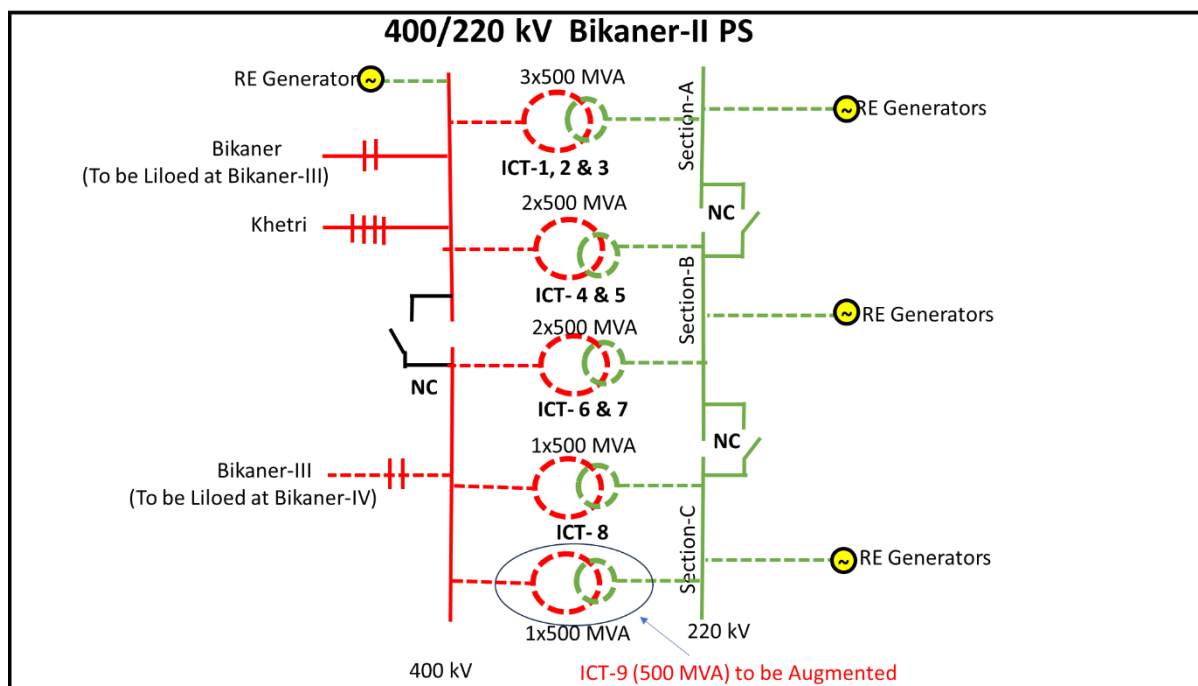

Figure : Schematic of 400/220 kV Bikaner-II PS

The scheme is under implementation with following details:

**Project Name** - Augmentation of Transformation Capacity at 400/220 kV Bikaner-II PS in Rajasthan by 400/220 kV, 1x500 MVA ICT (9<sup>th</sup>)

Sl. No.	Scope of the Transmission Scheme	Capacity/km	Implementation timeframe
1	Augmentation of Transformation Capacity at 400/220 kV Bikaner-II PS in Rajasthan by 400/220 kV, 1x500 MVA ICT (9th) along with associated transformer bays	500 MVA, 400/220 kV ICT- 1 no.  400 kV ICT bay- 1 no.  220 kV ICT bay- 1 no	18 months from the date of issuance of CTUIL OM i.e. 18.01.2026
<b>Total Estimated Cost:</b>			<b>INR 54.60 Cr</b>

This scheme was awarded to POWERGRID through RTM mode vide CTU OM dated 18.07.2024 with an implementation time frame of 18 months i.e. anticipated by 18.01.2026.

**(d) Augmentation with 400/220 kV 3x500 MVA(6th to 8th) ICTs at Fatehgarh-IV PS(Sec-II)**

In the 29<sup>th</sup> CMETS-NR meeting held on 17/05/24, it was deliberated that at present, total connectivity granted at Fatehgarh-IV PS(Sec-II) is 4980 MW(4880+100 MW on hold due to reallocation matter currently subjudice). Out of this, 3480 MW(3380+100 on hold) is granted at 220 kV and 1500 MW is granted at 400 kV level. Establishment of Fatehgarh-IV PS(Sec-II) and associated transmission system is currently under bidding as part of “Transmission System for evacuation of power from Rajasthan REZ Ph-IV (Part-2:5.5 GW) (Jaisalmer/ Barmer Complex)” and expected to be awarded in May’24.

The above scheme involves establishment of 765/400/220 kV Fatehgarh-IV PS(Sec-II) along with transformation capacity of 4x1500 MVA 765/400 kV ICTs & 5x500 MVA 400/220 kV ICTs. Considering the connectivity of 3480 MW granted at 220 kV level of Fatehgarh-IV PS(Sec-II), augmentation of 3x500 MVA ICTs are required to be taken up matching with the above scheme for evacuation of power as well as to meet N-1 compliance.

Grid-India enquired about RE generation being interconnected at Fatehgarh-IV PS(Sec-I). CTU stated that at Fatehgarh-IV PS (Sec-I), about 2025MW connectivity is granted and both the sections i.e. section-I & II shall be electrically isolated through sectionalizer (normally open) with compliance will be separate for both the sections. Accordingly, N-1 of 400/220kV ICTs is being ensured in both the sections. CEA agreed for the proposal

Accordingly, the following ICT augmentation scheme is agreed (in 29<sup>th</sup> CMETS-NR) at Fatehgarh-IV PS(Sec-II) PS in ISTS:

- Augmentation with 400/220 kV, 3x500 MVA (6th ,7th & 8th) ICTs at Fatehgarh-IV PS(Sec-II) along with associated transformer bays

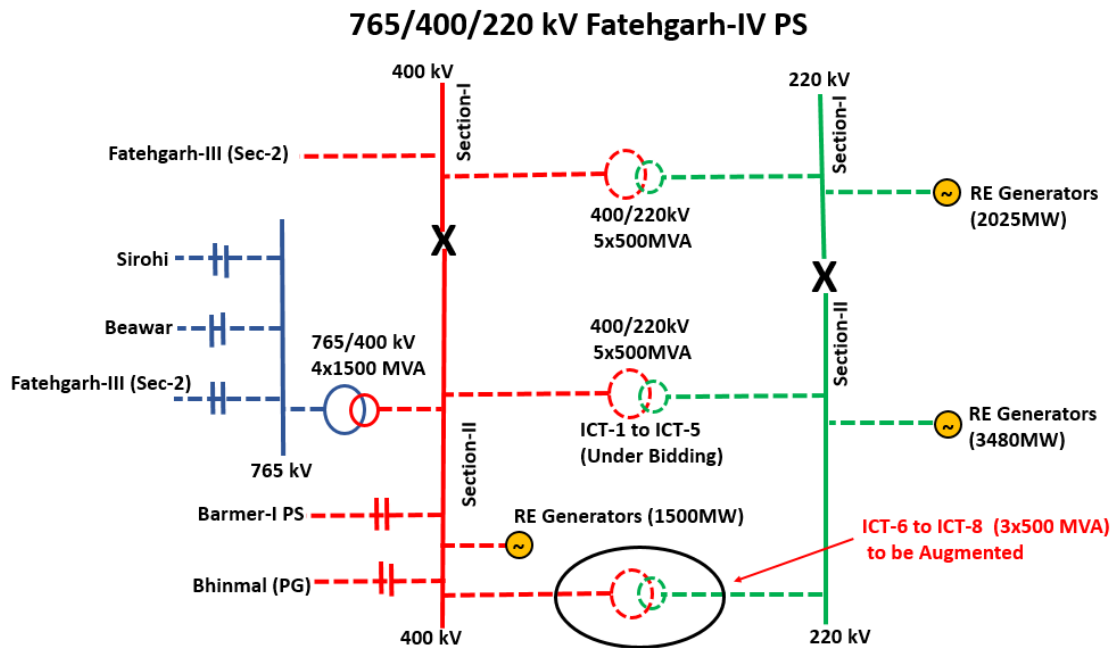

Figure : Schematic of 765/400/220 kV Fatehgarh-IV PS

Above scheme was also discussed in 21<sup>st</sup> NCT meeting held on 06/08/24 & NCT approved the scheme of Augmentation with 400/220 kV 3x500 MVA (6<sup>th</sup> to 8<sup>th</sup>) ICTs at Fatehgarh-IV PS(Section-II) under TBCB route. The scheme details are as below:

**Project Name** - Augmentation with 400/220 kV, 3x500 MVA (6<sup>th</sup>, 7<sup>th</sup> & 8<sup>th</sup>) ICTs at Fatehgarh-IV PS(Sec-II)

Sl. No.	Scope of the Transmission Scheme	Item Description	Implementation Timeframe.
1.	Augmentation with 400/220 kV, 3x500 MVA (6 <sup>th</sup> , 7 <sup>th</sup> & 8 <sup>th</sup> ) ICTs at Fatehgarh-IV PS(Sec-II) along with associated transformer bays  <i>Estimated Cost : 167.79 Cr</i>	<ul style="list-style-type: none"> <li>500 MVA, 400/220 kV ICT - 3 nos.</li> <li>400kV ICT bays – 3 nos.</li> <li>220 kV ICT bay – 3 nos.</li> </ul>	Matching with Rajasthan REZ Ph-IV (Part-2:5.5 GW) Scheme  (Rajasthan REZ Ph-IV (Part-2:5.5 GW) Scheme expected SPV transfer: Aug'24)
<b>Total Estimated Cost:</b>			<b>₹ 167.79 Crore</b>

**(e) Augmentation with 400/220 kV 1x500 MVA(3rd & 4th) ICT at Barmer-I PS**

In the 29<sup>th</sup> CMETS-NR meeting held on 17/05/24, it was deliberated that At present total connectivity granted at Barmer-I PS is 3050 MW at 220 kV. Out of this 3050 MW, 1350 MW connectivity is granted with Transmission System for evacuation of power from Rajasthan REZ Ph-IV (Part-2:5.5 GW) (Jaisalmer/ Barmer Complex) scheme. The connectivity beyond 1350 MW(upto 4000 MW) is being

granted with Rajasthan REZ Ph-IV (Part-4:3.5 GW) scheme which was recently approved in the 19th NCT meeting held on 29.04.2024.

Establishment of 765/400/220kV Barmer-I PS (765/400KV: 3x1500MVA, 400/220KV: 2x500MVA) and associated system is currently under bidding as part of “Transmission System for evacuation of power from Rajasthan REZ Ph-IV (Part-2:5.5 GW) (Jaisalmer/Barmer Complex)” and is expected to be awarded in May’24. Therefore, considering the connectivity of 1350 MW granted at 220 kV level of Barmer-I PS with Ph-IV Part-2 scheme, augmentation of 1x500 MVA ICT (3rd) is required to be taken up matching with the above scheme(Rajasthan REZ Ph-IV (Part2:5.5 GW)) for reliable evacuation of power.

CEA stated that with 1350MW quantum at Barmer-I PS, N-1 compliance also needs to be taken care and therefore 2 nos. of 400/220kV ICTs (3rd & 4th) shall be required for evacuation as well as to meet N-1 requirement. CTU stated that considering 4000MW RE quantum (Potential) at 220kV level of Barmer-I PS, total 9 no’s, of ICTs are required for evacuation as well as to meet N-1 compliance. Out of 9 nos. of ICTs, 2nos. of ICTs (1st & 2nd) were approved as part of Rajasthan REZ Ph-IV (Part-2:5.5 GW) scheme and 5x500MVA ICTs (5th to 9th ) is also approved in recent NCT meeting as part of Rajasthan REZ Ph-IV (Part-4:3.5 GW) scheme and with proposed augmentation (3rd ICT), total 8 nos. ICTs is being considered whereas 9th ICT can be taken at later stage to meet N-1 compliance requirement. CEA stated that there is some time gap (5-6 months) in commissioning of two schemes i.e. REZ Ph-IV (Part-2:5.5 GW) & REZ Ph-IV (Part-4:3.5 GW) and for such period 400/220kV ICTs will be n-1 non-compliant. CEA stated that 2x500MVA (3rd & 4th) may be considered. SECI enquired whether GNA Operationalization of RE applicants at Barmer-I PS may also be affected in absence of 4th ICT required to meet N-1 compliance. CTU stated that GNA Operationalization of RE applicants will not be dependent on ICT required to meet N-1 compliance, however considering discussions in meeting, 400/220 kV, 2x500 MVA (3rd & 4th) ICTs at Barmer-I PS is considered to meet power evacuation as well as transformer n-1 requirement.

Accordingly, the following ICT augmentation scheme is agreed (in 29<sup>th</sup> CMETS-NR) at Fatehgarh-IV PS(Sec-II) PS in ISTS:

- Augmentation with 400/220 kV, 2x500 MVA (3rd & 4th) ICTs at Barmer-I PS along with associated transformer bays

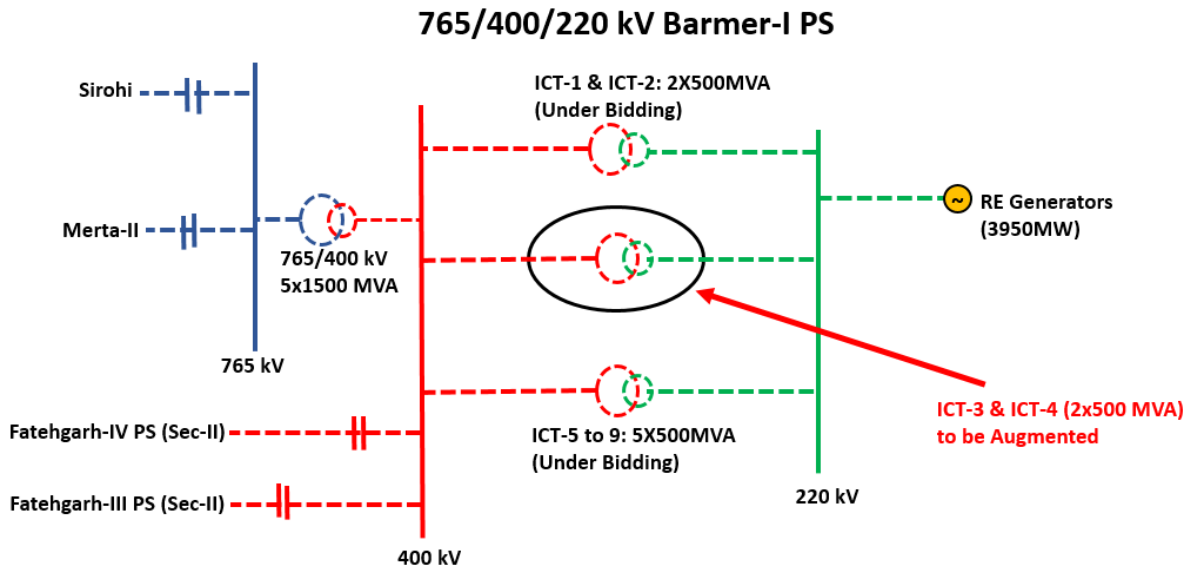

Figure : Schematic of 765/400/220 kV Barmer-I PS

Above scheme was also discussed in 21<sup>st</sup> NCT meeting held on 06/08/24 & NCT approved the scheme of Augmentation with 400/220 kV 2x500 MVA (3<sup>rd</sup> & 4<sup>th</sup>) ICTs at Barmer-I PS under TBCB route. The scheme details are as below:

**Project Name** - Augmentation with 400/220 kV, 2x500 MVA (3<sup>rd</sup> & 4<sup>th</sup>) ICTs at Barmer-I PS

Sl. No.	Scope of the Transmission Scheme	Item Description	Implementation Timeframe.
2.	Augmentation with 400/220 kV, 2x500 MVA (3 <sup>rd</sup> & 4 <sup>th</sup> ) ICTs at Barmer-I PS along with associated transformer bays	<ul style="list-style-type: none"> <li>500 MVA, 400/220 kV ICT - 2 nos.</li> <li>400kV ICT bays – 2 nos.</li> <li>220kV ICT bay – 2 nos.</li> </ul>	Matching with Rajasthan REZ Ph-IV (Part-2:5.5 GW) Scheme  (Rajasthan REZ Ph-IV (Part-2:5.5 GW) Scheme expected SPV transfer: Aug'24)
<b>Total Estimated Cost:</b>			<b>₹ 111.86 Crore</b>

**(f) Transmission system strengthening to facilitate evacuation of power from Bhadla/Bikaner complex**

Comprehensive Transmission scheme for evacuation of power from Rajasthan REZ Ph-IV (Part-1) (Bikaner Complex) is under implementation for power transfer of 7.7GW incl. 4GW from Bikaner-III PS. The scheme comprises 765kV EHVAC corridor from Bikaner-III PS towards load centers of

Delhi/UP. As part of the above scheme, 765 kV Bikaner-III -Neemrana 2xD/c and Neemrana-II – Bareilly (PG) D/c lines are being implemented.

Further, as part of Rajasthan REZ Ph-III (20GW) Transmission scheme, Bhadla-III & Ramgarh PS are being established for integration of 6.5GW & 2.9 GW RE potential respectively. Ramgarh PS is also being inter-connected with Bhadla-III for evacuation of RE power. In order to facilitate evacuation of 9.4GW RE power from Ramgarh/Bhadla-III PS (6.5GW+2.9GW) from Bhadla-III onwards, 765kV Bhadla-III - SikarII D/c line with implementation schedule of Mar'25 [for about 2.9GW power transfer requirement] as well as 6GW HVDC corridor (+800kV Bhadla (HVDC) -Fatehpur (HVDC)) with implementation schedule of Feb'28 (Pole-1) & Aug'28 (Pole-2) is being implemented as part of Ph-III scheme.

Accordingly, in 19th CMETS-NR meeting, 765kV Bhadla-III - Bikaner-III D/c line was agreed to meet evacuation requirement from Bhadla-III PS onwards for some RE generators coming up in 2025-26 as well as Optimal utilization of EHVAC transmission system beyond Bikaner-III PS while providing flexibility of power transfer from Bhadla/Bikaner RE clusters. The scheme is under bidding.

To facilitate above evacuation of power as well as to meet N-1 criteria (beyond 765kV Bareilly S/s), additional 400 kV corridor i.e. 400kV Bareilly(765/400kV) – Bareilly(PG) D/c line (Quad) (2nd) along with augmentation with 1x1500 MVA, 765/400 kV ICT at Bareilly (765/400kV) S/s (3rd) is proposed. The above strengthening scheme is also included as part of connectivity system of various RE applications granted at Bikaner-III.

CEA agreed for the proposal, however they enquired about short circuit of 400kV Bareilly(765/400kV) & Bareilly(PG) S/s. CTU stated that short circuit level of 400kV Bareilly(765/400kV) is about 52kA (designed capacity:50 kA) & 400kV Bareilly(PG) S/s is about 51kA (designed capacity: 40 kA), however with above proposed scheme short circuit level increase marginally (1-2kA) on both the substations. CTU stated that to reduce short circuit level of various substation in NR, wherein short circuit level is already high (from designed capacity), measures will be taken as part of comprehensive scheme in a phased manner. Grid India stated that scheme is agreeable and they do not have any comment on above scheme.

POWERGRID vide mail 21.01.23 confirmed the space availability for 765/400kV ICT (3rd) at Bareilly (PG) (765/400kV) as well as 2 nos. of 400kV line bays each at Bareilly (PG) (765/400kV) and Bareilly (PG) (400kV).

NCT (19<sup>th</sup> NCT held on 29/04/2024) decided implementation of the Transmission system strengthening to facilitate evacuation of power from Bhadla/Bikaner complex to be undertaken under TBCB.

Summary of the scheme is given below:

SI No.	Name of the scheme and tentative implementation timeframe	Estimated Cost (₹ Crores)	Remarks
1.	Transmission system strengthening to facilitate evacuation of power from Bhadla/Bikaner complex  Tentative implementation timeframe : 18 months from the date of SPV transfer	198.75	Recommended under TBCB route with PFCCL as BPC

Detailed scope of the scheme is given below:

Sl. No.	Scope of the Transmission Scheme	Item Description
1.	400 kV Bareilly (765/400 kV) – Bareilly (PG) D/c line (Quad) (2 <sup>nd</sup> )	Line length : 4 kms <ul style="list-style-type: none"> <li>• 400 kV line bays -2 Nos. (at Bareilly (765/400 kV) S/s</li> <li>• 400 kV line bays - 2 Nos. (at Bareilly (PG) S/s)</li> </ul>
2.	Augmentation with 1x1500 MVA, 765/400 kV ICT (3 <sup>rd</sup> ) at Bareilly (765/400 kV) S/s	<ul style="list-style-type: none"> <li>• 765/400 kV, 1500 MVA ICT - 1 No.</li> <li>• 765 kV ICT bay - 1 No.</li> <li>• 400 kV ICT bay - 1 No.</li> </ul>

Note:

- The line lengths mentioned above are approximate as the exact length shall be obtained after the detailed survey
- POWERGRID to provide space for 2 Nos. of 400 kV line bays each at Bareilly (765/400 kV) and 400 kV Bareilly (PG) S/s
- POWERGRID to provide space for 1500 MVA ICT at Bareilly (765/400 kV) along with its associated bays.

**(g) Transmission system for evacuation of power from Fatehgarh/Barmer Complex as part of Rajasthan REZ Ph-IV (Part-4 :3.5 GW) [Fatehgarh/Barmer Complex]**

Considering grant of connectivity to RE generators in Fatehgarh/Barmer complex as well as for evacuation of power beyond above complex, transmission scheme for evacuation of power from Fatehgarh/Barmer Complex as part of Rajasthan REZ Ph-IV (Part-4 :3.5GW) has been envisaged. The scheme shall also facilitate evacuation of additional RE power evacuation from Nagaur complex (2 GW) which will require some immediate transmission system requirement i.e. 400/220 kV ICTs and 220 kV line bays along with NR-WR inter regional corridors.

The transmission scheme was discussed and technically approved in the 71st NRPC meeting held on 29.01.2024 and recommended to NCT. Further, reactive compensation of some of the lines was modified and the same was approved in 49th TCC/72nd NRPC meeting held on 29th-30th March 2024.

Scheme was deliberated in 27<sup>th</sup> CMETS-NR meeting held on 10.01,24. In the meeting RVPN stated that they do not have any drawl requirement in future from proposed Merta-2 S/s. In view of envisaged RE potential in Nagaur distt., space provision to be kept for 220kV scope i.e. 400/220kV ICTs., 220 kV line bays for drawl & 220kV Sectionalization bay for RE injection

Considering grant of connectivity to RE generators in Fatehgarh/Barmer complex as well as for evacuation of power beyond above complex, Transmission system for evacuation of power from Fatehgarh/Barmer Complex as part of Rajasthan REZ Ph-IV (Part-4 :3.5 GW) [Fatehgarh/Barmer Complex]was agreed in Joint study meetings (28.12.23 & 09.01.24) as well as in 27<sup>th</sup> CMETS-NR meeting held on 10.01.24. The scheme shall also facilitate evacuation of additional power evacuation

from Nagaur complex (2GW) for which some immediate transmission system requirement from Nagaur complex and Inter regional corridors requirement shall be assessed

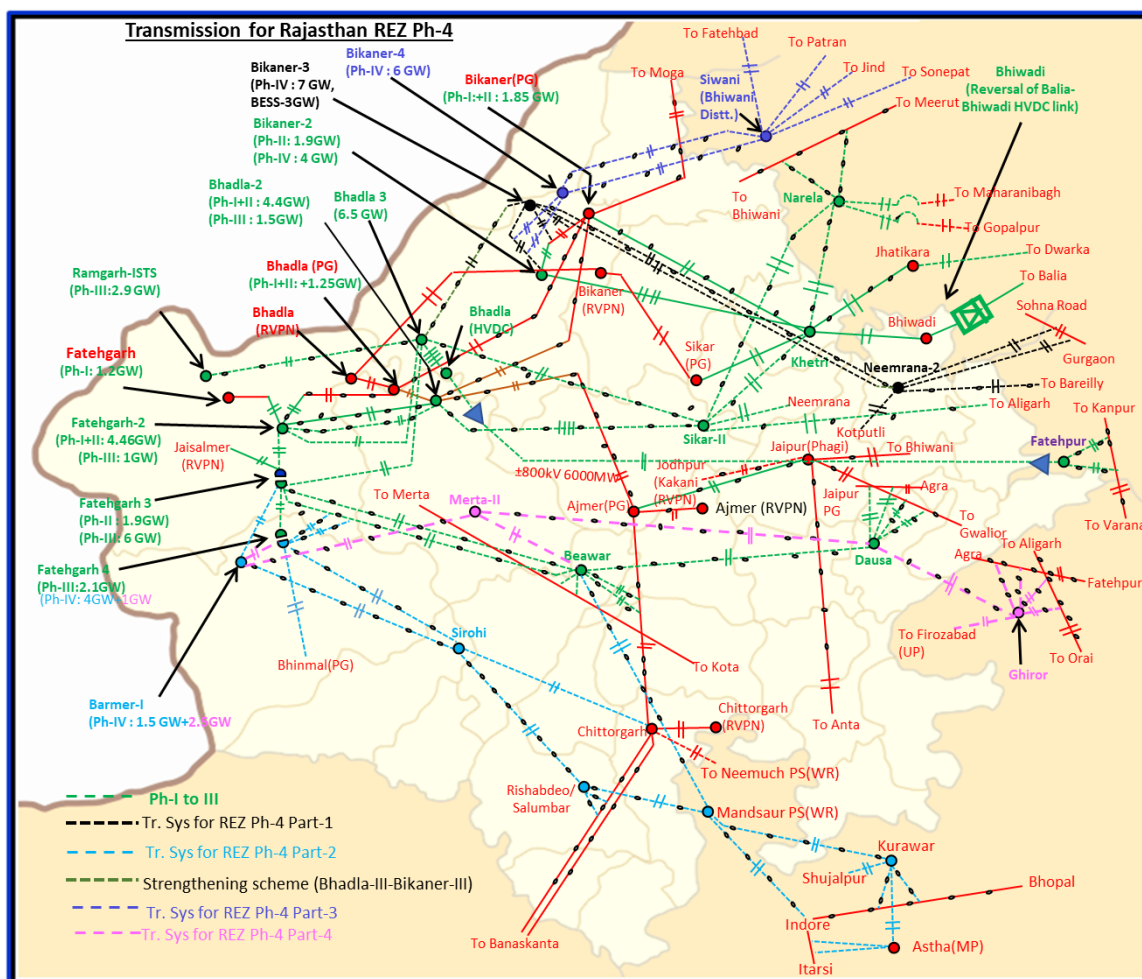

Fig: Transmission system for Rajasthan REZ Ph-IV (Part-4 :3.5GW) [Fatehgarh/Barmer complex]

NCT (in 19<sup>th</sup> NCT held on 29/04/2024) recommended implementation of the Transmission system for evacuation of power from Rajasthan REZ Ph-IV (Part-4: 3.5 GW): Part A and Part B to be undertaken under TBCB.

Transmission system for evacuation of power from Rajasthan REZ Ph-IV (Part-4: 3.5 GW): Part A

Summary of the scheme is given below:

SI No.	Name of the scheme and tentative implementation timeframe	Estimated Cost ( Crores)	Remarks
1	Transmission system for evacuation of power from Rajasthan REZ Ph-IV (Part-4: 3.5 GW):	5,845.93	Recommended under TBCB route with RECPDCL as BPC

	Part A Tentative implementation timeframe: 24 months from the date of SPV transfer		
--	--	--	--

Detailed scope of the scheme:

Sl. No.	Description of Transmission Element	Scope of work (Type of Substation/Conductor capacity/km/no. of bays etc.)
1	Augmentation with 765/400 kV, 2x1500 MVA Transformer (4th & 5th) at Barmer-I PS	<ul style="list-style-type: none"> <li>• 765/400 kV 1500 MVA ICTs- 2 nos.</li> <li>• 765 kV ICT bays-2 no.</li> <li>• 400 kV ICT bays- 2 no.</li> </ul>
2	Augmentation of 5x500 MVA (5 <sup>th</sup> to 9 <sup>th</sup> ), 400/220 kV ICTs at Barmer-I PS	<ul style="list-style-type: none"> <li>• 400/220 kV 500 MVA ICTs- 5 nos.</li> <li>• 400 kV ICT bays-5 nos.</li> <li>• 220 kV ICT bays- 5 nos.</li> </ul>
3	220kV line bays (6 nos.) for RE connectivity at Barmer-I PS	<ul style="list-style-type: none"> <li>• 220 kV line bays- 6 nos.</li> </ul>
4	400kV Sectionalizer bay (1 set), 220kV Sectionalizer bay (1 set) along with 220kV BC (1 nos.) and 220 kV TBC (1 nos.) at Barmer-I PS	<ul style="list-style-type: none"> <li>• 400 kV Sectionalizer bay: 1 set</li> <li>• 220 kV Sectionalizer bay: 1 set</li> <li>• 220 kV BC (1 nos.) bay and 220 kV TBC (1 nos.) bay</li> </ul>
5	STATCOM (2x+300MVA <sub>r</sub> ) along with MSC (4x125 MVA <sub>r</sub> ) & MSR (2x125 MVA <sub>r</sub> ) along with 2 nos. 400 kV bays at Barmer-I PS	<ul style="list-style-type: none"> <li>• STATCOM (2x+300MVA<sub>r</sub>) MSC (4x125 MVA<sub>r</sub>) &amp; MSR (2x125 MVA<sub>r</sub>)</li> <li>• 400kV bays at Barmer-I PS – 2 nos.</li> </ul>
6	Fatehgarh-IV PS (Sec-2) – Barmer-I PS 400kV D/c line (Quad)	<p>Line Length ~45 km (Quad)</p> <ul style="list-style-type: none"> <li>• 400 kV line bays at Fatehgarh-IV PS (Sec-2) – 2 nos.</li> <li>• 400 kV line bays at Barmer-I PS – 2 nos.</li> </ul>
7	<p>Establishment of 765/400kV, 2x1500 MVA S/s at suitable location near Ghiror (Dist. Mainpuri) along with 2x240 MVA<sub>r</sub> (765kV) &amp; 2x125 MVA<sub>r</sub> (420kV) bus reactor at Ghiror S/s (UP)</p> <p><b>Future provisions at Ghiror S/s:</b></p>	<p>Ghiror S/s- AIS</p> <ul style="list-style-type: none"> <li>• 765/400 kV 1500 MVA ICTs- 2 nos. (7x500 MVA including one spare unit)</li> <li>• 765 kV ICT bays-2 no.</li> <li>• 400 kV ICT bays- 2 no.</li> <li>• 765kV line bays : 8 nos. (for LILO of Aligarh(PG)-Orai(PG) D/c, LILO of</li> </ul>

Sl. No.	Description of Transmission Element	Scope of work (Type of Substation/Conductor capacity/km/no. of bays etc.)
	<p><b>Space for</b></p> <ul style="list-style-type: none"> <li>• 765/400kV ICTs along with bays- 4</li> <li>• 765 kV line bays along with switchable line reactors – 6</li> <li>• 765kV Bus Reactor along with bay: 1 nos.</li> <li>• 400 kV line bays along with switchable line reactor –6</li> <li>• 400 kV Bus Reactor along with bays: 1 no.</li> <li>• 400kV Sectionalizer bay: 1 set</li> <li>• 400/220kV ICT along with bays -4 nos.</li> <li>• 220 kV line bays for drawl -6 nos.</li> <li>• 220kV Sectionalizer bay: 1 set</li> <li>• 220 kV BC (2 nos.) bays and 220 kV TBC (2 nos.) bays</li> <li>• STATCOM (2x±300MVA<sub>r</sub>, 4x125MVA<sub>r</sub> MSC, 2x125MVA<sub>r</sub> MSR) along with 400kV bays (2 nos.)</li> </ul>	<p>Agra (PG) – Fatehpur(PG) S/c &amp; 765kV interconnection with Dausa S/s)</p> <ul style="list-style-type: none"> <li>• 400kV line bays : 2 nos. (for 400kV interconnection with Firozabad (UPPTCL) S/s)</li> <li>• 240 MVA<sub>r</sub> Bus Reactor-2 no. (7x80 MVA<sub>r</sub>, including one spare unit)</li> <li>• 765 kV Bus reactor bays-2 no.</li> <li>• 125 MVA<sub>r</sub> Bus Reactor-2 nos.</li> <li>• 400 kV Bus reactor bays- 2 no.</li> <li>• 110MVA<sub>r</sub> spare reactor unit (single phase)-1 no.</li> </ul>
8	<p>Dausa - Ghiror 765 kV D/c line along with 330MVA<sub>r</sub> switchable line reactor at Ghiror end and 240 MVA<sub>r</sub> switchable line reactor at Dausa end for each circuit of Dausa - Ghiror 765 kV D/c line</p>	<p>Line Length -305 km</p> <ul style="list-style-type: none"> <li>• 765 kV, 240 MVA<sub>r</sub> switchable line reactors at Dausa S/s end– 2 nos.</li> <li>• 765 kV, 330 MVA<sub>r</sub> switchable line reactors at Ghiror S/s S/s end– 2 nos.</li> <li>• Switching equipment for 765kV, 240 MVA<sub>r</sub> switchable line reactors at Dausa S/s end – 2 nos.</li> <li>• Switching equipment for 765kV, 330 MVA<sub>r</sub> switchable line reactors at Ghiror S/s end – 2 nos.</li> </ul>
9	<p>LILLO of both ckt of 765 kV Aligarh (PG) - Orai (PG) D/c line at Ghiror S/s along with 240 MVA<sub>r</sub> switchable line reactor for each circuit at Ghiror S/s end of 765 kV Ghiror - Orai (PG) D/c line</p>	<p>Length -15km (LILLO length)</p> <ul style="list-style-type: none"> <li>• 765 kV, 240 MVA<sub>r</sub> switchable line reactors at Ghiror S/s end– 2 nos.</li> <li>• Switching equipment for 765kV, 240 MVA<sub>r</sub> switchable line reactors at Ghiror S/s end – 2 nos.</li> </ul>
10	<p>LILLO of one ckt of 765kV Agra (PG) – Fatehpur (PG) 2xS/c line at Ghiror along with 240 MVA<sub>r</sub> switchable line reactor at Ghiror end of 765 kV Ghiror -Fatehpur (PG) line</p>	<p>Length -30km (LILLO length)</p> <ul style="list-style-type: none"> <li>• 765 kV, 240 MVA<sub>r</sub> switchable line reactors at Ghiror S/s end– 1 no.</li> </ul>

Sl. No.	Description of Transmission Element	Scope of work (Type of Substation/Conductor capacity/km/no. of bays etc.)
		<ul style="list-style-type: none"> <li>Switching equipment for 765kV, 240 MVAR switchable line reactor at Ghiror S/s end – 1 no.</li> </ul>
11	400kV Ghiror-Firozabad (UPPTCL) D/c line (Quad)	Line Length ~50 km (Quad)
12	2 nos. 765kV line bays at Dausa S/s	<ul style="list-style-type: none"> <li>765 kV line bays at Dausa S/s – 2 nos</li> </ul>
13	2 nos. 400kV line bays at Firozabad (UPPTCL) S/s	<ul style="list-style-type: none"> <li>400 kV line bays at Firozabad (UPPTCL) S/s – 2 nos</li> </ul>

Note:

- The line lengths mentioned above are approximate as the exact length shall be obtained after the detailed survey
- Developer of Fatehgarh-IV PS (Sec-2) & Barmer-I PS shall provide space for 2 Nos. of 400 kV line bays each at Fatehgarh-IV PS (Sec-2) & Barmer-I PS
- Developer of Barmer-I PS shall provide space for 765/400 kV ICTs(2x1500 MVA), 400/220 kV ICTs (5x500 MVA), 220 kV line bays(6 Nos.), 400 kV Sectionalizer bay (1 set), 220 kV Sectionalizer bay (1 set), 220kV BC (1 Nos.), 220 kV TBC (1 Nos.), STATCOM & associated 2 Nos. of 400 kV bays at Barmer-I PS
- UPPTCL shall provide space for 2 Nos. of 400 kV line bays at Firozabad S/s
- POWERGRID shall provide space for 2 Nos. of 765 kV line bays at Dausa S/s along with space for 2 Nos. of 240 MVAR switchable line reactors

Transmission system for evacuation of power from Rajasthan REZ Ph-IV (Part-4: 3.5 GW): Part B

Summary of the scheme is given below:

SI No.	Name of the scheme and tentative implementation timeframe	Estimated Cost (₹ Crores)	Remarks
1.	Transmission system for evacuation of power from Rajasthan REZ Ph-IV (Part-4 :3.5 GW): Part A  Tentative implementation timeframe : 24 months from the date of SPV transfer	6,394.94 Cr	Recommended under TBCB route with RECPDCL as BPC

Detailed scope of the scheme:

Sl. No.	Description of Transmission Element	Scope of work (Type of Substation/Conductor capacity/km/no. of bays etc.)
1	<p>➤ Establishment of 765/400 kV, 2x1500 MVA S/s at suitable location near Merta (Merta-II Substation) along with 2x240 MVA<sub>r</sub> (765kV) &amp; 2x125 MVA<sub>r</sub> (420kV) bus reactor at Merta-II S/s</p> <p><b>Future provisions at Merta-II S/s:</b></p> <p><b>Space for</b></p> <ul style="list-style-type: none"> <li>• 765/400kV ICTs along with bays- 4</li> <li>• 765 kV line bays along with switchable line reactors – 8</li> <li>• 765kV Bus Reactor along with bay: 1 nos.</li> <li>• 400 kV line bays along with switchable line reactor –8 nos.</li> <li>• 400 kV line bays – 2 nos.</li> <li>• 400 kV Bus Reactor along with bays: 1 no.</li> <li>• 400kV Sectionalizer bay: 2 sets</li> <li>• 400/220kV ICTs along with bays -4 nos.</li> <li>• 220 kV line bays for RE injection -5 nos.</li> <li>• 220kV Sectionalizer bay: 2 set</li> <li>• 220 kV BC (2 nos.) bays and 220 kV TBC (2 nos.) bays</li> <li>• STATCOM (2x±300MVA<sub>r</sub>, 4x125MVA<sub>r</sub> MSC, 2x125MVA<sub>r</sub> MSR) along with 400kV bays (2 nos.)</li> </ul>	<p><b>Merta-II S/s -AIS</b></p> <ul style="list-style-type: none"> <li>• 765/400 kV 1500 MVA ICTs- 2 nos. (7x500 MVA including one spare unit)</li> <li>• 400/220 kV 500 MVA ICTs -2 Nos.</li> <li>• 765 kV ICT bays-2 no.</li> <li>• 400 kV ICT bays- 4 no.</li> <li>• 220 kV ICT bays- 2 no.</li> <li>• 765kV line bays: 4 nos. (for 765kV interconnection with Dausa S/s &amp; Barmer-I PS)</li> <li>• 400kV line bays: 2 nos. (for 400kV interconnection with Beawar S/s)</li> <li>• 240 MVA<sub>r</sub> Bus Reactor-2 no. (7x80 MVA<sub>r</sub>, including one spare unit)</li> <li>• 765 kV Bus reactor bays-2 no.</li> <li>• 125 MVA<sub>r</sub> Bus Reactor-2 nos.</li> <li>• 400 kV Bus reactor bays- 2 no.</li> <li>• 220 kV line bays: 3 nos. (for RE connectivity)</li> <li>• 220 kV BC (1 nos.) bay and 220 kV TBC (1 nos.) bay</li> <li>• 110MVA<sub>r</sub> spare reactor unit (single phase)-1 no.</li> </ul>
2	<p>Barmer-I PS – Merta-II 765 kV D/c line along with 330 MVA<sub>r</sub> switchable line reactor for each circuit at each end of Barmer-I PS – Merta-II 765 kV D/c line</p>	<p>Line Length -345 km</p> <ul style="list-style-type: none"> <li>• 765 kV, 330 MVA<sub>r</sub> switchable line reactors at Barmer-I PS end– 2 nos.</li> <li>• 765 kV, 330 MVA<sub>r</sub> switchable line reactors at Merta-II S/s end– 2 nos.</li> <li>• Switching equipment for 765kV, 330 MVA<sub>r</sub> switchable line reactors at Barmer-I PS end – 2 nos.</li> </ul>

Sl. No.	Description of Transmission Element	Scope of work (Type of Substation/Conductor capacity/km/no. of bays etc.)
		<ul style="list-style-type: none"> <li>Switching equipment for 765kV, 330 MVAR switchable line reactors at Merta-II S/s end – 2 nos.</li> <li>110MVAR spare reactor unit at Barmer-I PS (single phase)-1 no.</li> </ul>
3	Merta-II – Beawar 400 kV D/c line (Quad)	Line Length ~55 km (Quad)
4	Merta-II – Dausa 765 kV D/c line along with 240 MVAR switchable line reactor for each circuit at each end of Merta-II – Dausa 765kV D/c line line	Line Length -250 km <ul style="list-style-type: none"> <li>765 kV, 240 MVAR switchable line reactors at Dausa S/s end– 2 nos.</li> <li>765 kV, 240 MVAR switchable line reactors at Merta-II S/s end– 2 nos.</li> <li>Switching equipment for 765kV, 240 MVAR switchable line reactors at Dausa S/s end – 2 nos.</li> <li>Switching equipment for 765kV, 240 MVAR switchable line reactors at Merta-II PS end – 2 nos.</li> </ul>
5	2 nos. 765kV line bays each at Barmer-I PS & Dausa S/s	<ul style="list-style-type: none"> <li>765 kV line bays at Barmer-I PS – 2 nos.</li> <li>765 kV line bays at Dausa S/s – 2 nos</li> </ul>
6	2 nos. 400kV line bays at Beawar S/s	<ul style="list-style-type: none"> <li>400 kV line bays at Beawar S/s – 2 nos.</li> </ul>

Note:

- The line lengths mentioned above are approximate as the exact length shall be obtained after the detailed survey
- Developer of Barmer-I PS shall provide space for 2 Nos. of 765 kV line bays along with space for 2 Nos. of 330 MVAR switchable line reactor and space for spare reactor unit (110 MVAR) at Barmer -I PS
- Sterlite shall provide space for 2 Nos. of 400 kV line bays at Beawar S/s
- POWERGRID shall provide space for 2 Nos. of 765 kV line bays at Dausa S/s along with space for 2 Nos. of 240 MVAR switchable line reactor

**(h) Transmission system for evacuation of power from Rajasthan REZ Ph-V (Part-1 :4 GW) [Sirohi/Nagaur] Complex, Transmission scheme**

In 30th CMETS -NR meeting held on 18/06/2024 It was deliberated that Renewable Energy Zones (REZs) were identified by MNRE/SECI with a total capacity of 181.5 GW for likely benefits by the year 2030 in eight states, which includes 75GW REZ potential in Rajasthan comprising of 15 GW Wind

and 60 GW Solar. In this regard a Committee on Transmission Planning for RE was constituted by MOP for planning of the requisite Inter State Transmission System required for the targeted RE capacity by 2030 for which a Comprehensive transmission plan for evacuation of 75GW RE potential from Rajasthan was evolved.

Details of schemes approved/Under Planning scheme as part of above is as under:

S.No	Transmission Scheme	RE Potential	Status
<b>A</b>	<b>Under Bidding/ Approved</b>		
1	Rajasthan REZ Ph-IV (Part-1 :7.7GW) (Bikaner Complex)	14 GW (Solar 14GW, BESS:6GW)  Bikaner-II : 3.7GW  Bikaner-III: 4GW	Awarded
2	Rajasthan REZ Ph-IV (Part-2 :5.5GW) (Jaisalmer/Barmer Complex)	5.5GW (Solar)  Fatehgarh-IV: 4 GW  Barmer-I: 1.5 GW	Under Bidding
3	Rajasthan REZ Ph-IV (Part-3 :6GW) (Bikaner Complex)	6 GW (Solar)  Bikaner-IV:6GW	Under Bidding
<b>B</b>	<b>Planned/Under Planning</b>		
1	Rajasthan REZ Ph-IV (Part-4 :3.5GW) (Jaisalmer/Barmer Complex)	3.5 GW (Solar)  Fatehgarh-IV: 1 GW  Barmer-I: 2.5 GW	<b>Recently approved in NCT</b>
2	Rajasthan REZ Ph-IV (Part-5 : 6GW) (Barmer Complex)	6 GW (Solar)  Barmer-II : 6GW	<b>Timeframe : 2029 (HVDC)</b>
3	Rajasthan REZ Ph-IV (Part-6 : 6GW) (Bhadla/Bikaner Complex)	6 GW (Solar)  Bhadla-IV: 2 GW  Bikaner-V: 4 GW*	
<b>4</b>	<b>Rajasthan REZ Ph-V (Part-1: 4GW) (Sirohi/Nagaur Complex)</b>	<b>4 GW (Solar)</b>  <b>Sirohi: 2 GW</b>  <b>Nagaur: 2 GW</b>	<b>Present proposal</b>  <b>Timeframe : 2027 (EHVAC)</b>

To evolve the transmission scheme, studies are carried out in two timeframes:

- 1) Phase-1 (2027) for 4GW: Transmission scheme for Rajasthan REZ Ph-V (Part-1: 4GW) (Sirohi/Nagaur Complex)

- 2) Phase-2 (2029) for 12GW : Transmission scheme for Rajasthan REZ Ph-IV (Part-5 : 6GW) (Barmer Complex) & Rajasthan REZ Ph-IV (Part-6 : 6GW) (Bhadla/Bikaner Complex)

It was stated that a Joint study meeting was held on 09.05.24 with stakeholders in NR to deliberate & finalize the Transmission system for evacuation of power from Rajasthan REZ Ph-V (Part-1 :4 GW) [Sirohi/Nagaur] Complex, Transmission scheme for Rajasthan REZ Ph-IV (Part-5 : 6GW) (Barmer Complex) & Rajasthan REZ Ph-IV (Part-6 : 6GW) (Bhadla/Bikaner Complex). As part of Rajasthan REZ Ph-V (Part-1 :4 GW) [Sirohi/Nagaur], following ISTS scheme was proposed in the Joint study meeting

#### **Immediate Evacuation of Power from Sirohi PS (2GW)**

- 5x500MVA, 400/220kV ICTs at Sirohi S/s along with transformer bays

#### **Common Evacuation of Power from Sirohi PS (2GW) & Merta-II PS (2GW)**

#### **NR-WR Inter regional corridor**

- Sirohi – Mandsaur PS 765KV D/c line (~ 320kms) along with 240 MVAR switchable line reactor at Sirohi S/s end and 330 MVAR switchable line reactor at Mandsaur PS end for each circuit of Sirohi – Mandsaur PS 765KV D/c line

#### **Western region**

- Mandsaur PS – Khandwa (New) 765kV D/c line (~230km.) along with 240MVAR switchable line reactor for each circuit at each end of Mandsaur PS – Khandwa (New) 765kV D/c line

In the above Joint study meeting, Grid-India observations on proposed transmission schemes as well as on All India Study files (2027 & 2029 time frame) were deliberated and same was also communicated by Grid-India vide their mail dated 09.05.24

Major observations on 2027 timeframe files are as under:

- 1) LGB of All India file – Higher demand considered in NR,WR & ER region, Merit order of thermal generating units
- 2) Blocking of Reactive support from units with no generation
- 3) High loading and low voltages in the ER grid in solar peak hours
- 4) N-1 non compliance of ICTs in Rajasthan (Intra state and Inter state)
- 5) N-1 non compliance of ICTs in Western region
- 6) Critical loading in 400 kV Farakka – Kahalgaon D/C, 400 kV New Ranchi – PPSP D/C and ICTs in West Bengal in real time
- 7) Off loading of 765kV Ghiror – Aligarh D/c line
- 8) Critical loading and higher angular separation (>20 degree) under N-1 contingency in few EHVAC lines in NR as well as Low SCR of Sirohi PS
- 9) Very low voltages at various nodes in the system including in NR RE Complex
- 10) Provide Study cases for other scenarios (other than solar maximized scenario)

In the above Joint study meeting, it was decided that comprehensive schemes discussed may be segregated in two phases (Phase-1: Transmission scheme for Rajasthan REZ Ph-V (Part-1: 4GW)

(Sirohi/Nagaur Complex) & Phase-2: Transmission scheme for Rajasthan REZ Ph-IV (Part-5 : 6GW) (Barmer Complex) & Rajasthan REZ Ph-IV (Part-6 : 6GW) (Bhadla/Bikaner Complex).

In Phase-1, PSS/E files shall be modified w.r.t discussion and comments received from Grid-India on 2027 time frame study files. Revised PSS/E files will be circulated to NR stakeholders for finalization of proposed scheme in next Joint study/CMETS-NR meeting (Jun'24).

Accordingly as part of Phase-1, revised PSS/E files for solar maximized scenario (SC-4 & 7) along with Scenario 8 (evening peak) & Scenario 9 (night off peak) files for 2027 time frame along with reply to Grid-India observations on 2027 timeframe files was sent on 04.06.24 to all stakeholders.

Subsequently, Grid India vide their mail dated 13.06.24 sent observations on revised PSS/E files. In the CMETS-NR meeting, CEA agreed to the proposed transmission scheme. Grid-India stated that they do not have any specific comment on proposed transmission scheme, however their observation on other issues on 2027 timeframe files are as under:

- a) Higher demand considered in WR & ER region
- b) High loading in EHVAC lines in ER and in WR-ER in solar peak hours
- c) N-1 non compliance of ICTs in Rajasthan (Intra state and Inter state)
- d) Dynamic simulation studies incl. inertia studies for various contingency scenarios
- e) Critical loading and higher angular separation (>20 degree) under N-1/N-1-1 contingency of 765kV Bikaner-Moga D/c line as well as Low SCR of Sirohi PS

It was deliberated in CMETS-NR meeting that Transmission planning is carried out for peak load scenario. In view of that CTU analyze the historical data (Feb'23 to Feb'24) for solar maximized time and it is observed that load growth of more than 7 % is observed in winter solar peak hours in All India & most of the regions. Green Hydrogen and bulk consumer load is considered over and above to EPS demand in planning studies .

For high loading in EHVAC lines in ER, Grid-India stated that 400 kV Farakka – Kahalgaon D/c & 400 kV New Ranchi – PPSP D/c is overloaded in real time also. In view of RE addition in NR and WR and backing down of thermal units in ER, critical loading is observed in ER and WR-ER corridors in planning studies. In view of that strengthening is being taken up on priority with progressive addition of solar generation in next 2-3 years so that schemes in ER are available for absorption of RE power in Eastern region.

In the meeting, CTU stated that Reconductoring of some of the lines i.e. 400kV Farakka – Kahalgaon and 400kV Talcher – Meramundali is recently agreed in CMETS-ER meeting with a completion schedule of 18 months from allocation. In real time, loading of 400 kV New Ranchi – PPSP D/c is in order as line rating was considered lower, however in planning studies loadings are higher. Reconductoring of Ranchi New – New PPSP 400kV D/c line and any other augmentation in ISTS and commensurate STU network would be identified based on the joint study meeting scheduled next month with WBSETCL. Reconductoring of 400kV Farakka – Sagardighi and 400kV Rourkela – Chaibasa 400kV D/c line would be taken up for discussion in CMETS-ER meeting (Jul'24). An additional corridor from WR to ER needs to be envisaged for relieve the loading around Ranchi area considering LGB of 2027 and 2029 timeframe and change in power flow pattern due to envisaged Green hydrogen load. Augmentation of ICTs in WBSETCL, DVC & Odisha area have been already informed to

respective STUs in various CMETS-ER meetings and joint meetings. Matter will be further emphasized to STUs/DVC to take up augmentation of ICTs within time.

It was also decided that due to huge power flow in solar peak hours from NR-ER and WR-ER, and thermal backdown in ER, there may be other system strengthening requirement within ER incl. requirement discussed above. Such transmission strengthening requirements will be planned shortly and taken up for stakeholder consultation based on study results under various scenarios.

For intra state ICT overloading in Rajasthan, RVPN stated that for Hindaun ICT work awarded in Mar'24 (24 months schedule) and for Chittorgarh, Heerapura and Deedwana ICTs proposal is in process. CTU requested RVPN to expediate the approval of augmentation of ICTs so that same is available in 2027 timeframe.

CTU stated that Loading of 400/220kV Kota (PG) ICT is higher due to low dispatch of KTPS generation units. Loading of Bhinmal ICT is higher in Sc-7 due to increasing demand. Implementation of ICTs may take less time (18 months from approval) as compared to transmission schemes for RE evacuation (30 months from approval). It was stated that necessary augmentation (Kota and Bhinmal ICT) will be carried out in ISTS in consultation with stakeholders once space availability from TSP for Bhinmal and real time loading data from NRLDC is received for implementation in 2027 timeframe or earlier. NRLDC agreed for the same

For dynamic simulation studies and stability studies, CTU stated presently there are convergence issues being faced in dynamic simulation for 2027 scenario for which consultation with IIT Mumbai is also under progress. In view of that, Dynamic simulation studies for planning scenario may take some time.

In 30th CMETS-NR meeting, CTU requested that Grid-India may also share present time frame converged dynamic file which will help to resolve convergence issues in dynamics file for 2027 timeframe w.r.t Generator models (conventional/RE) used by Grid-India. In the CMETS-NR meeting Grid-India stated that they are also facing convergence issues for present timeframe file and prepared dynamics file with some assumptions. They also shared some dynamic data with CTU in the past but only dynamic data will not help to resolve convergence issue. However for preparation for planning stage dynamic file, CTU and Grid-India can work together to prepare load flow first w.r.t dynamics file and subsequent Dynamic data file (Dyr) shall be prepared with help of models available with Grid-India.

CTU also stated that considering the severe convergence issues in dynamics file, it will be converged on truncated network specific to RE pockets in Rajasthan rather than to converge the file on All India level. NRLDC stated that for transient studies, truncated network modelling will be sufficient.

Further, in the meeting CTU stated that to resolve the issue of higher angular separation (>20 degree) under N-1/N-1-1 contingency of 765kV Bikaner-Moga D/c line, suitable strengthening scheme is already under planning. As part of above scheme LILO of 765kV Bikaner -Moga line is envisaged which will reduce the angular separation (< 30 degree).

Regarding observation for Inertia response of units, NRLDC stated that it may be checked in dynamics file once prepared for critical contingencies i.e. outage of large generation say 5-10GW in RE pockets. In the above condition, inertial response of generation units, Grid frequency variation, df/dt, synchronous condenser response may be analyzed. Same was agreed.

For low SCR at Sirohi PS(4.2), CTU stated that no additional connectivity will be granted beyond 2 GW at 220kV level of Sirohi PS with proposed system (400/220kV ICTs at Sirohi PS+765kV Sirohi - Mandasaur). With growing interconnection and planned network in future, SCR at Sirohi may increase.

Grid-India also enquired about space for STATCOM at Sirohi PS. CTU stated that 765/400kV Sirohi S/s are under bidding and to be implemented as part of Transmission system for evacuation of power from Rajasthan REZ Ph-IV (Part 2: 5.5 GW) (Jaisalmer/Barmer Complex).CTU stated that provision of space was kept at Sirohi PS for installation of STATCOM in future based on requirement.

No other comments were received from Stakeholders on proposed scheme. Considering receipt of connectivity application of new RE generators in Sirohi & Nagaur/Merta complexes & based on discussion, following connectivity transmission scheme is agreed as part of Rajasthan REZ Ph-V (Part-1 :4 GW) scheme:

- 1. Transmission system for immediate Evacuation of Power from Sirohi S/s (2GW)**
  - 5x500MVA, 400/220kV ICTs at Sirohi S/s along with associated transformer bays
  - 6 nos. 220kV line bays at Sirohi S/s for RE interconnection
  - 220 kV Sectionalizer bay (1 set) along with 220 kV BC (2 Nos.) bay and 220 kV TBC (2 Nos.) bay at Sirohi S/s
- 2. Transmission system for immediate Evacuation of Power from Merta-II S/s (2GW\*)**
  - 3x500MVA, 400/220kV ICTs at Merta-II S/s along with associated transformer bays
  - 4 nos. 220kV line bays at Merta-II S/s for RE interconnection
  - 220 kV Sectionalizer bay (1 set) along with 220 kV BC (1 No.) bay and 220 kV TBC (1 No.) bay at Merta-II S/s
- 3. Transmission system for Common Evacuation of Power from Sirohi PS (2GW) & Merta-II PS (2GW\*)**
  - a) NR-WR Inter regional corridor**
    - Sirohi – Mandasaur PS 765KV D/c line (~ 320kms) along with 240 MVAr switchable line reactor at Sirohi S/s end 330MVAr switchable line reactor at Mandasaur PS end for each circuit of Sirohi – Mandasaur PS 765KV D/c line
  - b) Western region**
    - Mandasaur PS – Khandwa (New) 765kV D/c line (~230km.) along with 240MVAr switchable line reactor for each circuit at each end of Mandasaur PS – Khandwa (New) 765kV D/c line

*\*Transmission scheme for immediate evacuation of 1GW RE from Merta-II S/s to facilitate connectivity to RE generation developers was deliberated and approved in 19th NCT meeting held on 29.04.24*

Above scheme was also discussed in 21<sup>st</sup> NCT meeting held on 06/08/24(Minutes of meeting awaited).

**(i) Implementation of 1 no. of 400 kV line bay at 765/400/220kV Bhadla-III PS for interconnection of M/s ReNew Solar (Shakti Six) Private Limited (450+550MW) RE project**

In the 23rd CMETS-NR meeting held on 29.08.2023, it was decided to grant connectivity under GNA with one no. of 400 kV bay under ISTS scope at Bhadla-III PS for interconnection of RE Project of M/s ReNew Solar (Shakti Six) Private Limited (450+550 MW).

M/s ReNew Solar (Shakti Six) Private Limited sought the start date of connectivity from 31.12.25 for 550 MW & 31.03.2025 for 450 MW. However, considering the schedule of common transmission as well as bay implementation schedule, connectivity under GNA was granted to M/s ReNew Solar (Shakti Six) Private Limited with the interim start date of 30.09.25. M/s ReNew Solar (Shakti Six) Private Limited has also submitted the Con-BGs.

M/s Renew vide letter 10.05.24 informed the revised commissioning schedule of their solar power projects (550MW+450MW) to 31.03.26 and requested to change the start date of connectivity & bay implementation date for both the applications (550+450 MW) to 31st March 2026 in the final grant of Connectivity.

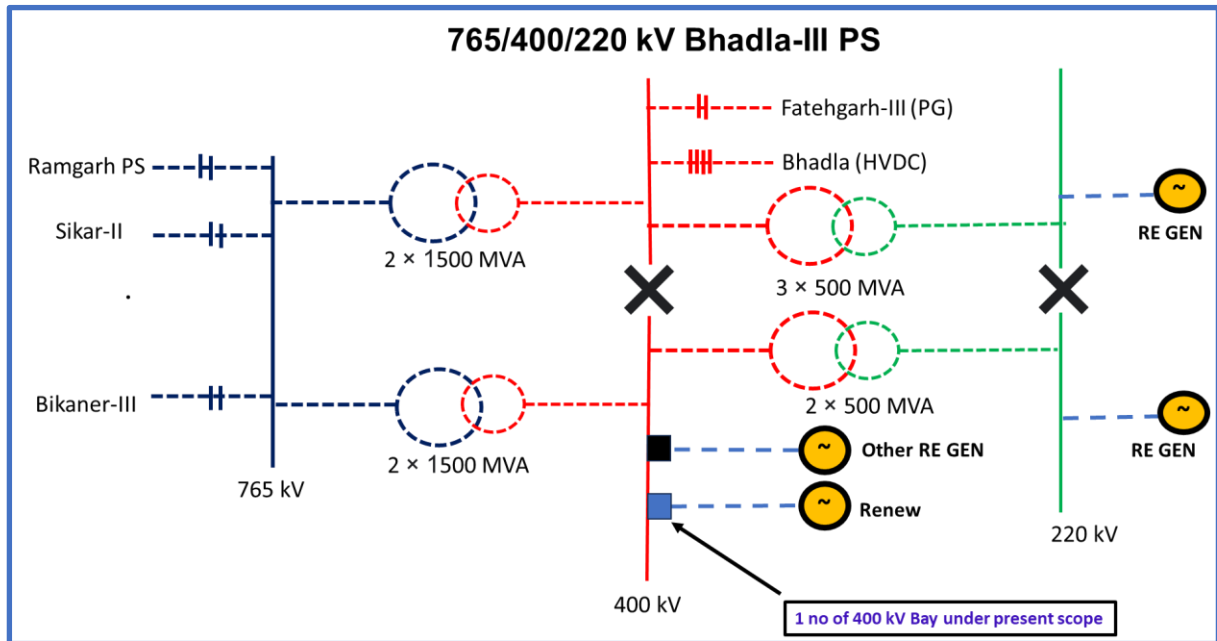

Figure: Schematic of 765/400/220 kV Bhadla-III PS

The scheme is under implementation with following details:

**Project Name** - Implementation of 1 no. of 400 kV line bay at 765/400/220kV Bhadla-III PS for interconnection of M/s ReNew Solar (Shakti Six) Pvt. Ltd.

Sl. No.	Scope of the Transmission Scheme	Capacity/km	Implementation timeframe
1	1 no. of 400 kV line bay at 765/400/220 kV Bhadla-III PS for interconnection of RE project (M/s ReNew Solar (Shakti Six) Private Limited)	400 kV line bay – 1 no.	31.03.26
<b>Total Estimated Cost:</b>			<b>INR 13.37 Crore</b>

This scheme was awarded to POWERGRID through RTM mode vide CTU OM dated 14.06.2024 with an implementation time frame of 31.03.2026.

**(j) Augmentation of 400/220kV, 1x500 MVA ICT (4th) to cater the N-1 contingency requirement at 765/400/220kV Bikaner PS**

In the 8th CMETS-NR meeting held on 30.06.22 and 56th NRPC meeting held on 29.07.22, agenda for Implementation of "N-1" contingency at RE pooling substations in NR was deliberated. In the meeting ICTs at RE pooling stations incl. 400/220kV, 500MVA (4th) ICT at Bikaner PS was agreed to be taken up for implementation with timeframe of 15 months from the date of allocation of project or evacuation requirement beyond 1000 MW at 220kV level of Bikaner PS whichever is later.

Further agenda for implementation of "N-1" contingency at RE pooling substations in NR was deliberated in 73rd NRPC meeting held on 21.05.24. In the meeting it was mentioned that under Connectivity Regulations 2009, Connectivity & LTA were different products. However, subsequent to notification of GNA regulations, connectivity has become a single merged product which is granted along with equal quantum of GNA.

At present, Bikaner (PG) S/s has 400/220 kV transformation capacity of 1000 MVA(2x500MVA). Further, 3rd 500MVA ICT is currently under implementation and is expected to be commissioned by Jun'24. At present, 935 MW of RE is already interconnected at Bikaner PS at 220 kV level and additional connectivity of 300 MW (70+105MW+125MW) is also granted to M/s Shikhar Surya (One) Pvt. Ltd. and applicant have completed the necessary transition requirement of connectivity of 300MW from Connectivity regulations 2009 to GNA Regulations 2022.

Considering above, total connectivity of 1235 MW is granted at 220kV level of Bikaner (PG). Therefore, there is requirement of 4th, 500MVA ICT at Bikaner (PG) to meet N-1 compliance beyond 1000 MW at 220kV level.

In the 73rd NRPC meeting, It was also deliberated that considering project timelines of ICT augmentation, implementation timeframe for above augmentation may be kept as 18 months instead of 15 months due to practical issues. In view of the deliberations, Augmentation with 400/220 kV, 500 MVA (4th) ICT at Bikaner PS along with associated transformer bays was agreed in 73rd NRPC meeting held on 21.05.24.

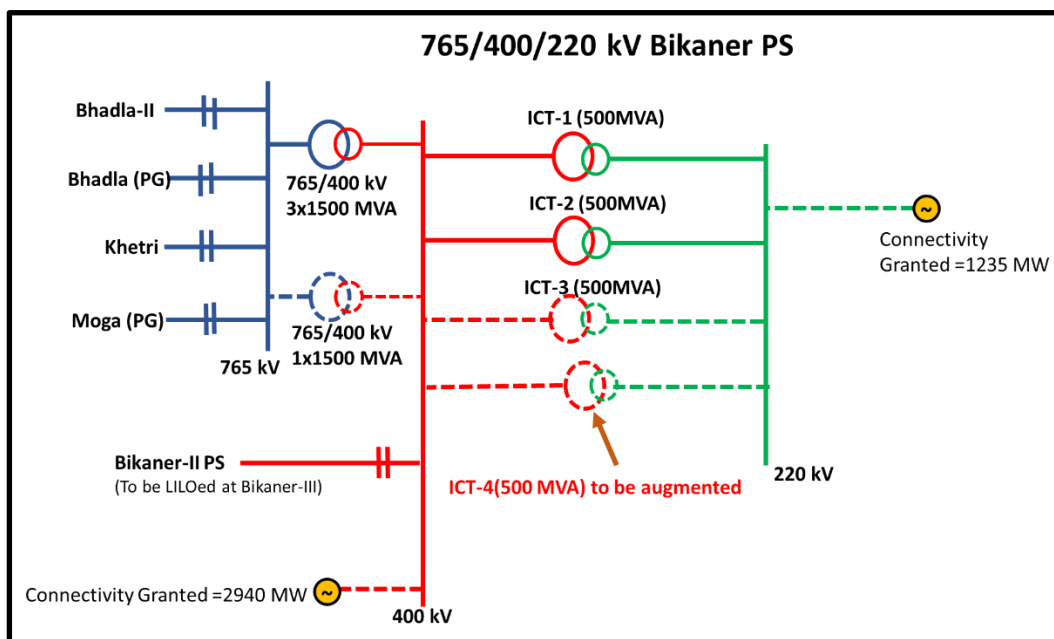

Figure: Schematic of 765/400/220 kV Bikaner PS

The scheme is under implementation with following details:

**Project Name** - . Augmentation of Transformation Capacity at 765/400/220kV Bikaner PS in Rajasthan by 400/220kV, 1x500 MVA ICT (4th)

Sl. No.	Scope of the Transmission Scheme	Capacity/km	Implementation timeframe
1	Augmentation of Transformation Capacity at 765/400/220kV Bikaner PS in Rajasthan by 400/220kV, 1x500 MVA ICT (4th) along with associated transformer bays	<ul style="list-style-type: none"> <li>➤ 500 MVA, 400/220 kV ICT- 1 no.</li> <li>➤ 400 kV ICT bay – 1 no.</li> <li>➤ 220 kV ICT bay – 1 no</li> </ul>	18 months from the date of issuance of OM by CTUIL i.e. 18.01.2026
<b>Total Estimated Cost:</b>			<b>INR 57.59 Crore</b>

This scheme was awarded to POWERGRID through RTM mode vide CTU OM dated 18.07.2024 with an implementation time frame of 18 months from the date of issuance of OM by CTUIL i.e. 18.01.2026

**(k) Augmentation with 400/220 kV, 1x500 MVA Transformer (10th) at Fatehgarh-2 PS**

Augmentation with 400/220 kV, 1x500 MVA, Transformer (10th) at Fatehgarh-2 PS was agreed as part of “transmission system for evacuation of power from REZ in Rajasthan (20 GW) under Phase-III Part J” in 5th NCT meeting held on 25.08.2021 and 02.09.2021. In that meeting, it was also agreed that Implementation of above ICT shall be taken up after LTA of 4490 MW at 220 kV level of Fatehgarh-2 PS. Subsequently, based on NCT recommendation, MoP vide OM dated 01.12.2021 awarded above transmission scheme to CTUIL with implementation timeframe of 15\_months from MoP OM or evacuation requirement beyond 4490 MW at 220 kV level of Fatehgarh-2 PS, whichever is later. Further, CTUIL vide letter dated 02.12.2021 allocated above scheme to POWERGRID based on MoP OM dated 01.12.2021.

220 kV level of Fatehgarh-2 PS is implemented in two sections i.e. Section-I & II. Further, both the 220kV sections are implemented in geographically opposite sides (way apart from each other and not electrically connected) as per GA and layout of pooling station. However, 400 kV & 765 kV bus remained common for both the yards. At present, RE Connectivity of 2490MW under GNA is granted at Section-I and 1970MW is granted at Section-II, thus making total connectivity at Fatehgarh-2 PS as 4460MW which is less than 4490 MW.

Subsequently, Manual on Transmission Planning Criteria was published by CEA in Mar’23. As per the above, ‘N-1’ reliability criteria may be considered for ICTs at the ISTS / STU pooling stations for renewable energy based generation of more than 1000 MW. As both the 220kV sections of Fatehgarh-2 PS are electrically isolated and have more than 1000MW RE connectivity in respective sections, ‘N-1’ criteria to be fulfilled at both the sections. Keeping above in view, 1x500MVA, 400/220kV ICT (6th) at Section-I was awarded which is under implementation (Jul’24).

Considering requirement of 400/220kV ICT (in Fatehgarh-II Section-II) for N-1 compliance in Fatehgarh-II PS |(Section-II), it was proposed that 1x500 MVA, 400/220 kV ICT (now 11th ICT) at Fatehgarh-II PS as approved by MoP vide OM dated 01.12.2021 based on recommendation in 5th NCT meeting may be taken up for implementation with 18 month implementation schedule considering

present timeline for ICT augmentation (instead of earlier 15 months) to fulfil ‘N-1’ criteria as per CEA Manual on Transmission Planning Criteria, 2023.

After deliberations, NCT (in 20<sup>th</sup> NCT meeting dated 25/06/2024) approved modification in the transmission scheme for “Augmentation with 400/220 kV, 1x500 MVA Transformer (10th) at Fatehgarh-2 PS” as mentioned below so that same can be taken up for implementation:

Earlier (as per MOP OM dated 01.12.21)	Amendment
<p>Augmentation with 400/220 kV, 1x500 MVA Transformer (10th) at Fatehgarh-2 PS</p> <ul style="list-style-type: none"> <li>• 400/220 kV 500 MVA ICT:1 no</li> <li>• 400 kV ICT bays – 1 Nos.</li> <li>• 220 kV ICT bays - 1 Nos.</li> </ul> <p><b>Implementation Timeframe- 15 months from MOP OM or evacuation requirement beyond 4490 MW at 220 kV level of Fatehgarh-2, whichever is later</b></p>	<p>Augmentation with 400/220 kV, 1x500 MVA Transformer (11th) at Fatehgarh-II PS (5th ICT in Fatehgarh-II section-II)</p> <ul style="list-style-type: none"> <li>• 400/220 kV 500 MVA ICT:1 no</li> <li>• 400 kV ICT bays – 1 no.</li> <li>• 220 kV ICT bays - 1 no.</li> </ul> <p><b>Implementation Timeframe- 18 months [for N-1 compliance in Fatehgarh-II PS (Section-II)]</b></p>

## 4.2 Punjab

### (a) Augmentation of 400/220 kV, 1x500 MVA (4th ) ICT at 400/220 kV Malerkotla (PG) substation

The proposal was deliberated in the 21st CMETS-NR meeting held on 31.07.23. In the meeting it was stated that from the loading pattern of Malerkotla ICTs (2x315+1x500 MVA), it was observed that Loading of ICTs have reached maximum of about 830 MW (on 1130 MVA) in past one year (Jun’22-Aug’22) in Paddy season of Punjab and reaching to N-1 limit level for peak Loading of ICTs (~830 MW). Further from rolling plan studies (2027-28) also, ICT loading (~880MW) is breaching N-1 limits increasing in Paddy season load of Punjab.

POWERGRID vide mail dated 28.06.23 confirmed the space availability of 400/220kV transformer (4th 1x500MVA) along with transformer bays at 400/220kV Malerkotla S/s (existing ICTs 2x315+1X500MVA). It was informed that 400kV side bay equipment shall be GIS type and 220kV side shall be routed to PSTCL yard through 220kV GIB/Cable whereas 220kV side ICT bay space may be confirmed by PSTCL.

CTU vide mail 17.07.24 requested PSTCL to provide their observations on requirement of ICT at Malerkotla S/s w.r.t. present and future demand. It was also requested PSTCL to provide details regarding space availability for 220kV side ICT bay at Malerkotla Substation.

In the CMETS-NR meeting, PSTCL stated that space is available and same was communicated to POWERGRID with 3-4 options along with most suitable option. CTU requested to provide the SLD, which was shared by PSTCL on 31.07.23. PSTCL enquired about techno economics of GIB/Cable. POWERGRID informed that based upon RoW issue and hindrance, the selection could be made, however, cable would be cheaper than GIB if both the options are feasible. PSTCL confirmed the requirement of ICT at Malerkotla S/s w.r.t. present and future demand. GRID India stated that ICT augmentation at Malerkotla may be considered based on PSTCL requirement, however, recently augmentation has been done at Patiala and this may affect ICT loadings at Malerkotla too. PSTCL again confirmed that ICT shall be required in paddy season and ICT loadings have been breached at Malerkotla for some instances in present Peddy season also despite of Patiala ICT augmentation. PSTCL also stated that as ICT implementation may also take about 2 years, same may be approved now so that ICT would be available by 2025.

CTU stated that this ICT augmentation may require 21 months for implementation as it involves 400kV side bay equipment of GIS type. Regarding 220kV side bay along with GIB/cable, PSTCL requested that 220kV works may be implemented in ISTS by same implementing agency assigned for transformer augmentation for better coordination, however, if 220kV work is assigned to PSTCL, 21 months time is sufficient for 220kV bay implementation. CEA also agreed for augmentation requirement at Malerkotla S/s. In view of that it was decided that ICT augmentation along with 400kV & 220kV side bay equipment is to be implemented in ISTS.

POWERGRID vide mail 11.09.23 to PSTCL informed that POWERGRID is planning to lay 220kV cable for ICT-4 ,for connection with PSTCL's 220kV bus at PSTCL Malerkotla. For this purpose, POWERGRID also sent proposed cable route to PSTCL for vetting purpose. PSTCL vide mail 14.09.23 informed POWERGRID that Proposed Cable route Draft Proposed Cable route (received through POWERGRID mail) is not feasible. PSTCL requested POWERGRID to provide the feasible cable route for further necessary action.

Subsequently, a committee comprising members of CTUIL & POWERGRID has visited the 400/220 kV Malerkotla S/s on 10.02.2024 and explored the options of installing 4th ICT at Malerkotla S/s, including the bays at Malerkotla PSTCL S/s. Following was concluded in the site visit report :

- For 220 kV connection between 400 kV and 220 kV side of Malerkotla S/s, underground cable seems feasible.
- Space is available for 4th ICT (400/220 kV, 1x500 MVA) at Malerkotla (PG) S/s including the 400 kV GIS bays
- Sufficient space is available in 220 kV (PSTCL) Malerkotla Switchyard for accommodating one no. 220 kV (AIS) bay. PSTCL has proposed 220 kV AIS Bay at location 3 for connecting the 4th ICT.

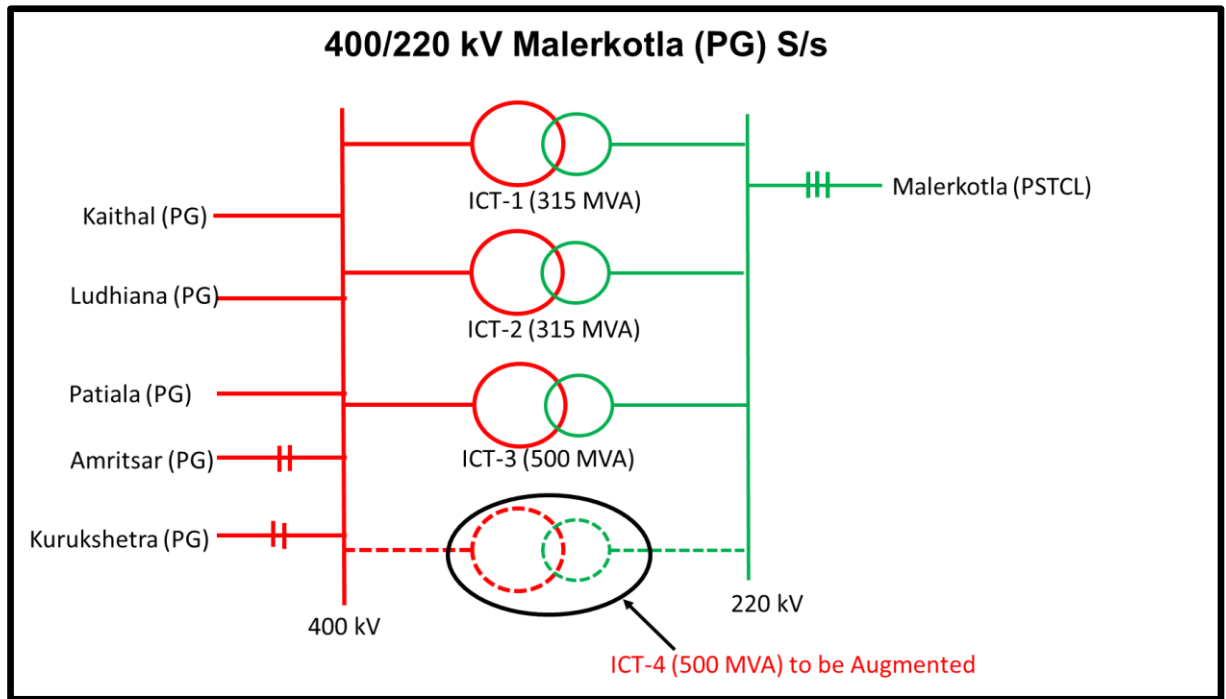

Figure : Schematic of 400/220 kV Malerkotla (PG)

The scheme is under implementation with following details:

**Project Name** - Augmentation of Transformation Capacity at 400/220kV Malerkotla(PG) S/s in Punjab by 400/220kV, 1x500MVA ICT (4th)

Sl. No.	Scope of the Transmission Scheme	Capacity/km	Implementation timeframe
1	<p>Augmentation of Transformation Capacity at 400/220kV Malerkotla(PG) S/s in Punjab by 400/220kV, 1x500MVA ICT (4th) along with associated transformer bays*</p> <p>*incl. extension of 400kV &amp; 220 kV side of ICT through Cable/GIB. 400kV side bay equipment shall be GIS type</p>	<ul style="list-style-type: none"> <li>➤ 500 MVA, 400/220 kV ICT - 1 no.</li> <li>➤ 400 kV ICT bays (GIS) – 1 no. (in new diameter with 1 no. additional bay for diameter completion) (refer note a)</li> <li>➤ 220 kV ICT bay – 1 no.</li> <li>➤ 400kV GIS duct (1ph) – 100m approx.</li> <li>➤ 220kV Cable (1ph) – 3200m approx.</li> <li>➤ 220 kV Cable Termination Kit: 8 nos.</li> </ul>	<p>21 months from the date of issuance of OM by CTUIL i.e. 14.03.2026 (refer note b)</p>
<b>Total Estimated Cost:</b>			<b>INR 88 Crore</b>

Note:

- (b) In view of GIS substation, one complete 400kV diameter with three Circuit Breakers (one and half switching scheme) shall be implemented at 400kV level for interconnection of ICT in one 400kV bay. Utilization of another 400kV bay of the diameter shall be identified in future
- (c) Best efforts shall be carried out to implement the transmission scheme within 18 months from the issuance of OM by CTUIL i.e. 14.12.2025.
- (d) PSTCL to provide space to ISTS licensee for implementation of 1 no. 220kV ICT bay (AIS) at 220kV Malerkotla(PSTCL) switchyard for termination of the above 400/220kV, 1x500MVA ICT (4th) ICT at 220kV side.

This scheme was awarded to POWERGRID through RTM mode vide CTU OM dated 14.06.2024 with an implementation time frame of 21 months from the date of issuance of OM by CTUIL i.e. 14.03.2026 (refer note b).

### 4.3 Jammu & Kashmir

#### (a) Transmission scheme for evacuation of power from Ratle HEP (850 MW) & Kiru HEP (624 MW)

Ratle HEP (850 MW) has applied for connectivity with ISTS. Accordingly a Comprehensive Transmission system for Ratle HEP has been identified. Recently CTU has received also connectivity application from Kiru HEP (624 MW) with commissioning schedule of Sep'26 (01.09.26) for which comprehensive Transmission system identified for Ratle HEP (commissioning progressively from 30.09.26) will be utilized along with some additional ICT augmentations, if required. Therefore, the scheme may be considered combindly for Ratle (850 MW) & Kiru HEP (624 MW).

Above, transmission scheme was agreed in the 26th CMETS-NR meeting held on 01.12.23 & reactive compensation was agreed in the 28th CMETS-NR meeting held on 27.03.24. Further scheme was also agreed in 49th TCC/72nd NRPC meeting held on 29th-30th Mar'24. Transmission System was agreed in 20th National Committee on Transmission (NCT) held on 25.06.2024.

After deliberations, NCT recommend/approved the transmission scheme for evacuation of power from Ratle (850 MW) & Kiru (624 MW) HEPs under {TBCB- Rs. 1213.87 Cr.; RTM- Rs. 195.67 Cr.} with the implementation time frame of 24 months.

#### **Summary of the scheme is given below:**

SI No.	Name of the scheme and tentative implementation timeframe	Estimated Cost (₹ Crores)	Remarks
1	Transmission scheme for evacuation of power from Ratle HEP (850 MW) & Kiru HEP (624 MW): Part-A  Tentative implementation timeframe : 24 Months from the date of SPV transfer	1213.87	Recommended under TBCB with RECPDCL as BPC
2	Transmission scheme for evacuation of power from Ratle HEP (850 MW) & Kiru HEP (624 MW): Part-B  Tentative implementation timeframe : 24 Months or matching with Transmission	195.67	Approved Under RTM

scheme for evacuation of power from Ratle HEP (850 MW) & Kiru HEP (624 MW) : PartA scheme whichever is later		
--	--	--

**Detailed scope of the scheme is given below:**

**Transmission scheme for evacuation of power from Ratle HEP (850 MW) & Kiru HEP (624 MW): Part-A**

Sl. No.	Description of Transmission Element	Scope of work (Type of Substation/Conductor capacity/km/no. of bays etc.)
1	LILO of 400 kV Kishenpur- Dulhasti line (Twin) at Kishtwar S/s along with associated bays at Kishtwar S/s	LILO Length- 3km • 400 kV Kishenpur - Kishtwar (LILO section) shall be on Twin HTLS (with minimum 2100 MVA capacity) configuration • 400 kV Dulhasti -Kishtwar (LILO section) shall be on Twin Zebra configuration • 400kV line bays at Kishtwar – 2 nos. (GIS) (line bays at Kishtwar S/s end shall be rated accordingly)
2	400 kV Kishenpur-Samba D/c line (Quad)  (only one circuit is to be terminated at Kishenpur utilizing 1 no. of 400kV vacated line bay at Kishenur S/s (formed with bypassing of one ckt of 400kV Kishtwar – Kishenpur 400kV D/c line (Quad) at Kishenpur) while second circuit would be connected to bypassed circuit of 400kV Kishtwar – Kishenpur line (Quad))	Length -36 km (Quad)
3	Bypassing of one ckt of 400kV Kishtwar – Kishenpur 400kV D/c line (Quad) at Kishenpur and connecting it with one of the circuit of Kishenpur-Samba 400kV D/c line(Quad), thus forming <b>400kV Kishtwar - Samba (Quad) direct line (one ckt)</b>	

Sl. No.	Description of Transmission Element	Scope of work (Type of Substation/Conductor capacity/km/no. of bays etc.)
4	1x80 MVAR Switchable line reactor at Samba end of 400kV Kishtwar-Samba 400kV line-165km (Quad) [formed after bypassing of 400kV Kishtwar – Kishenpur line (Quad) at Kishenpur and connecting it with one of the circuit of Kishenpur-Samba 400kV D/c line(Quad)]	<ul style="list-style-type: none"> <li>• 420 kV, 80 MVAR switchable line reactors at Samba S/s end– 1 nos.</li> <li>• Switching equipment for 420kV, 80 MVAR switchable line reactors at Samba S/s end – 1 no</li> </ul>
5	1x63 MVAR Switchable line reactor on each ckt at Jalandhar end of Kishenpur– Jalandhar D/c direct line -171km(Twin) (formed after bypassing both ckts of 400 kV Kishenpur – Samba D/c line (Twin) & 400 kV Samba – Jalandhar D/c line (Twin) at Samba and connecting them together to form Kishenpur– Jalandhar D/c direct line (Twin))	<ul style="list-style-type: none"> <li>• 420 kV, 63 MVAR switchable line reactors at Jalandhar S/s end– 2 nos.</li> <li>• Switching equipment for 420kV, 63 MVAR switchable line reactors at Jalandhar S/s end – 2 no</li> </ul>
6	400kV Samba- Jalandhar D/c line(Quad)  (only one circuit is to be terminated at Jalandhar utilizing 1 no. of 400kV vacated line bay at Jalandhar S/s (formed with bypassing of 400kV Jalandhar – Nakodar line (Quad) at Jalandhar) while second circuit would be connected to bypassed circuit of Jalandhar –Nakodar 400kV line (Quad))	Line Length -145 km
7	1x80 MVAR Switchable line reactor at Samba end of Samba – Nakodar direct line (Quad) (187km) formed after bypassing of 400 kV Jalandhar – Nakodar line (Quad) at Jalandhar and connecting it with one of the circuit of Samba-Jalandhar 400 kV D/c line(Quad Moose), thus forming Samba –Nakodar line (Quad)	<ul style="list-style-type: none"> <li>• 420 kV, 80 MVAR switchable line reactors at Samba S/s end– 1 no.</li> <li>• Switching equipment for 420kV, 80 MVAR switchable line reactors at Samba S/s end – 1 no.</li> </ul>
8	Bypassing 400kV Jalandhar – Nakodar line (Quad) at Jalandhar and connecting it with one of the circuit of Samba-Jalandhar 400kV D/c line(Quad Moose), thus forming 400kV Samba –Nakodar (Quad) direct line	

**Note:**

- M/s Sterlite shall provide space for 2 Nos. of 400 kV line bays (GIS) at Kishtwar S/s

- M/s POWERGRID shall provide space for 1 no. 80 MVAR Switchable line reactor (along with switching equipment) at Samba end of 400 kV Kishtwar-Samba 400 kV line
- M/s POWERGRID shall provide space for 2 Nos. 63 MVAR Switchable line reactor (along with switching equipment) at Jalandhar end of Kishenpur– Jalandhar D/c direct line (on each ckt)
- M/s POWERGRID shall provide space for 1 no. 80 MVAR Switchable line reactor (along with switching equipment) at Samba end of Samba –Nakodar direct line

**Transmission scheme for evacuation of power from Ratle HEP (850 MW) & Kiru (624 MW) HEP : Part B**

Sl. NO.	Description of Transmission Element	Scope of work (Type of Substation/Conductor capacity/km/no. of bays etc.)
1	Reconductoring of 400 kV Kishenpur-Kishtwar section (up to LILO point) with Twin HTLS (minimum 2100 MVA capacity) (formed after LILO of Kishenpur-Dulhasti line at Kishtwar S/s) along with bay upgradation works (2000 A to 3150 A) at Kishenpur end for above line.	Length – 120 km <ul style="list-style-type: none"> <li>• 400 kV Bay upgradation work- 1 no. bay at Kishenpur end</li> </ul>
2	Bypassing both ckts of 400 kV Kishenpur – Samba D/c line (Twin) & 400 kV Samba – Jalandhar D/c line (Twin) at Samba and connecting them together to form 400 kV Kishenpur– Jalandhar D/c direct line (Twin)  (4 Nos. of vacated 400 kV line bays at Samba S/s will be utilized for 400 kV Kishenpur-Samba D/c line (Quad) & 400 kV Samba- Jalandhar D/c line(Quad),	Length -0.5 km (Twin)
3	Bays upgradation works (2000A to 3150A) at Samba end (4 Nos. bays vacated after bypassing of Kishenpur – Samba D/c line (Twin) & 400 kV Samba – Jalandhar D/c line (Twin))	400 kV Bay upgradation works- 4 Nos. bays
4	Redundant Communication System for Dulhasti (NHPC) & Kishtwar (Sterlite) stations by installing OPGW on 400 kV Kishenpur-Kishtwar S/c line alongwith reconductoring work and FOTE at Dulhasti & Kishenpur.	Length – 120 km

**Note:**

- TSP shall also install OPGW on bypass section to form link between 400 kV Kishenpur– Jalandhar

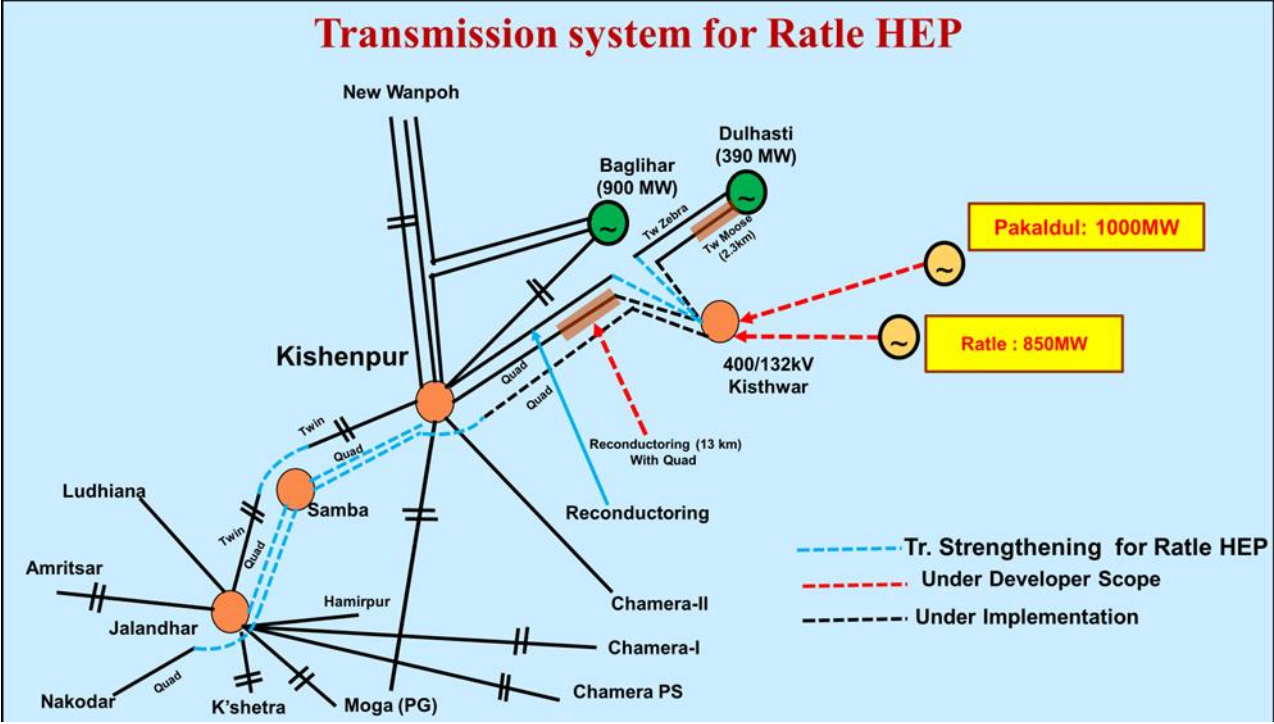

Figure: schematic for Transmission system for Ratle HEP

## 5. ISTS Network Expansion Scheme in Southern Region

Various transmission schemes have been discussed/finalized in the Consultative Meeting for Evolution of Transmission System of Southern Region (CMETS-SR) from Feb 2024 to July 2024. The details of the schemes are summarized below:

### 5.1 Andhra Pradesh

#### (a) Implementation of 3 nos. of 400kV line bays at Ananthapuram PS for integration of RE generation projects

Presently, Ananthapuram 400/220kV PS is under implementation by POWERGRID through TBCB route and is expected by Sept'25. Connectivity of about 1055 MW at 220kV and 2710 MW at 400kV has been granted at Ananthapuram to various RE generation projects. 12 nos. of 220kV line bays are already implementation. Connectivity of 1710 MW has been granted to M/s Renew Vikram Shakti Pvt. Ltd. at 400kV level with 2 nos. of 400kV bays in the 23rd CMETS-SR held on 29.09.2023. Further, Connectivity of 1000 has been granted to M/s ABC Cleantech Pvt. Ltd. at 400kV level with 1 nos. of 400kV bay in the 25<sup>th</sup> CMETS-SR held on 28.11.2023. The above RE generation projects have requested for implementation of 400kV bay at Ananthapuram PS under ISTS. The details are as below:

Sl. No.	Description of Transmission Element	Scope of work	Schedule
1	2 nos. of 400kV line bays at Ananthapuram PS for Connectivity to M/s Renew Vikram Shakti Pvt. Ltd.	400kV line bays – 2 Nos.	31.03.26
2	1 no. of 400kV line bay at Ananthapuram PS for Connectivity to M/s ABC Cleantech Pvt. Ltd.	400kV line bays – 1 Nos.	31.03.26

The scheme was deliberated and agreed in the 28<sup>th</sup> CMETS-SR held on 29.02.2024.

**Estimated cost: Rs. 46 Crore**

#### 400kV bays at Ananthapuram for integration of RE generation projects

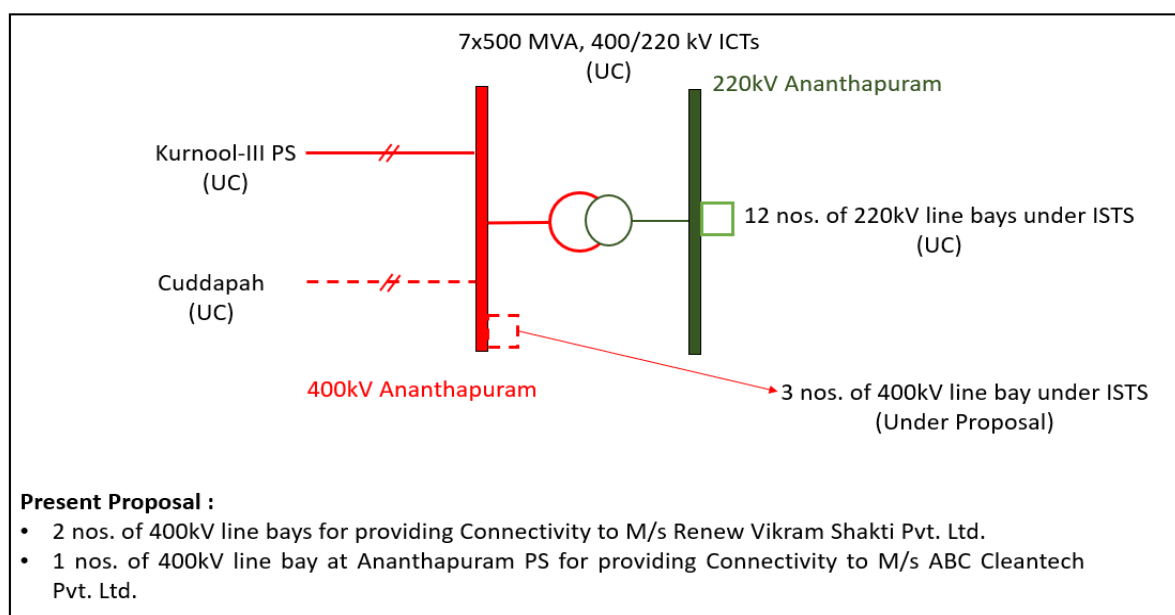

Above transmission scheme viz., Implementation of 3 nos. of 400kV line bays at Ananthapuram PS for integration of RE generation projects has been allocated to POWERGRID under RTM vide CTU letter dated 22.03.2024.

**(b) Transmission system strengthening at Kurnool-III PS for integration of additional RE generation projects**

Presently, Kurnool-III 765/400/220kV PS is under implementation by POWERGRID through RTM route and is expected by Nov'24. Further, for optimal utilisation of the pooling station, space provision for integration of additional 4.5 GW has been kept at Kurnool-III. The broad scheme is as below:

- Establishment of 765/400/220kV 3x1500 MVA, 9x500 MVA Kurnool-III PS
- Kurnool-III PS – Kurnool(new) 765 kV D/c line
- Kurnool-III PS – Maheshwaram (PG) 765 kV D/c line

Connectivity of about 2320 MW (1720 MW at 220kV level & 600 MW at 400kV level) have already been granted at Kurnool-III PS with the above under implementation transmission system. Further, CTU has received additional connectivity applications for 3770 MW (Solar: 3650 MW & Wind: 120 MW) seeking connectivity at Kurnool-III in the month of Nov'23. With this, the total connectivity quantum at Kurnool-III became about 6090 MW (1990 MW at 220kV level & 4100 MW at 400kV level). However, Kurnool-III PS is being implemented with 3x1500 MVA, 765/400kV transformation capacity. Therefore, grant of connectivity for additional 3770 MW shall require expansion of Kurnool-III PS and further transmission lines for evacuation of power from Kurnool-III PS. CTU also received additional connectivity applications for 1650 MW (PSP: 1250 MW & Solar: 400 MW) at Kurnool-III PS in the month of Jan'24. With this, the total connectivity quantum at Kurnool-III shall be about of 7740 MW (2390 MW at 220kV level & 5350 MW at 400kV level).

Accordingly, the following transmission system was deliberated in the 28<sup>th</sup> CMETS-SR held on 29.02.2024 and agreed for integration of additional RE generation projects and grant of Connectivity at Kurnool-III PS under the CERC GNA Regulations.

- Augmentation of transformation capacity of 3x1500 MVA, 765/400kV ICTs at Kurnool-III PS
- Kurnool-III PS – Chilakaluripeta 765 kV D/c line (about 260 km) with 240 MVAr switchable line reactors at both ends

CTU also received additional connectivity application for 260 MW at Kurnool-III PS in the month of Feb'24. Connectivity corresponding to 7740 MW have been granted / agreed for grant at Kurnool-III PS. However, for evacuation of additional power from Kurnool-III REZ and Ananthapuram REZ, 1x1500 MVA, 765/400 kV ICT (7<sup>th</sup>) is also required. Accordingly, augmentation of 1x1500 MVA 765/400kV ICT (7<sup>th</sup>) at Kurnool-III PS was proposed in the 29<sup>th</sup> CMETS-SR held on 28.03.2024. With this, the total connectivity quantum granted / agreed for grant at Kurnool-III PS shall be about of 8000 MW (2650 MW at 220kV level & 5350 MW at 400kV level).

The Connectivity have been granted for 600 MW to M/s Adani Renewable Energy Forty Two Ltd. for its PSP generation project at 400kV level with 2 nos. of 400kV line bays (under ISTS scope) for termination of its dedicated transmission line in the 23<sup>rd</sup> CMETS-SR held on 29.09.2023. Similarly, Connectivity have been granted for 3500 MW (800 MW & 3x900 MW) to M/s Indosol Solar Pvt. Ltd. for its Solar Power Park at 400kV level with 4 nos. of 400kV line bays (under ISTS scope) for termination of its dedicated transmission lines in the 26<sup>th</sup> CMETS-SR held on 29.12.2023. Similarly,

Connectivity have been agreed for grant for 1250 MW to M/s Adani Renewable Energy Fifty One Ltd. for its PSP generation project at 400kV level with 2 nos. of 400kV line bays (under ISTS scope) for termination of its dedicated transmission lines in the 28<sup>th</sup> CMETS-SR held on 29.02.2024. Accordingly, total 8 nos. of 400kV line bays are required to developed under ISTS for termination of dedicated transmission lines from the above generation projects.

The Transmission Scheme “Transmission system strengthening at Kurnool-III PS for integration of additional RE generation projects” was forwarded to SRPC for views on 08.04.2024. The scheme was deliberated in the 51<sup>st</sup> SRPC meeting held on 15.05.2024. SRPC vide letter dated 22.05.2024 has forwarded the views of Southern Region constituents.

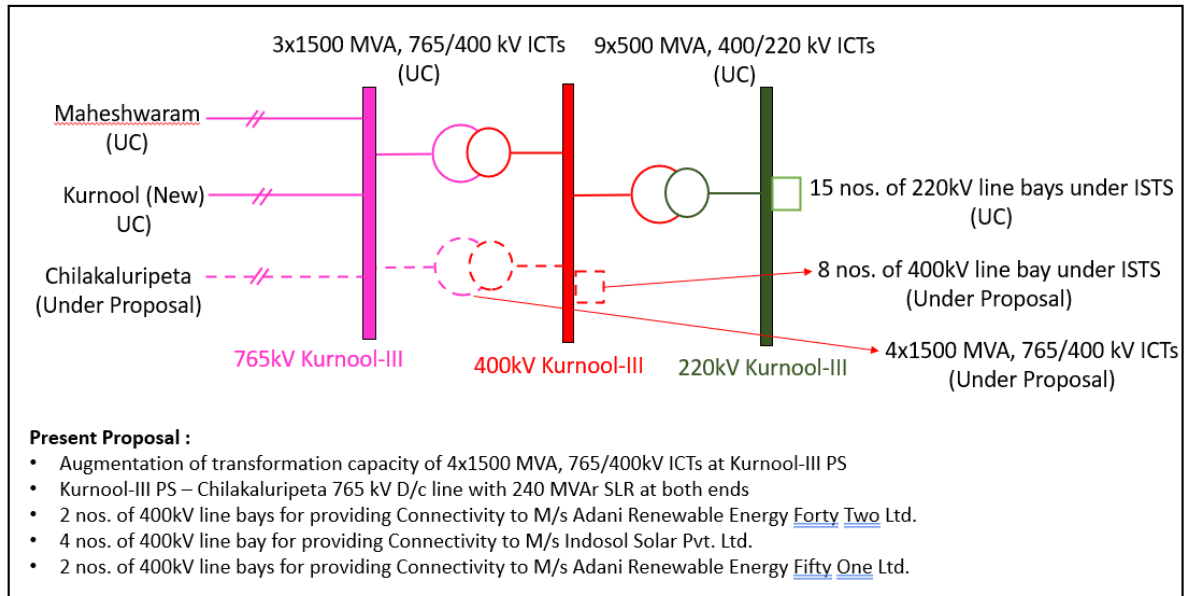

Package	Scope of the Transmission Scheme	Capacity /km	Schedule	Est. Cost (crs.)
A	Augmentation of transformation capacity of 3x1500 MVA, 765/400kV ICTs at Kurnool-III PS	<ul style="list-style-type: none"> <li>• 3x1500 MVA, 765/400kV ICT</li> <li>• 765kV ICT bay – 3 Nos.</li> <li>• 400kV ICT bay – 3 Nos.</li> <li>• 400kV Bus Sectionalizer – 1 Set</li> </ul>	24 months	2650
	Kurnool-III PS – Chilakaluripeta 765 kV D/c line with 240 MVar switchable line reactors at both ends	<p>~ 260 km</p> <ul style="list-style-type: none"> <li>• 765kV line bays – 2 nos. (at Kurnool-III PS)</li> <li>• 765kV line bays – 2 nos. (at Chilakaluripeta)</li> <li>• 765 kV, 240 MVar SLR at Kurnool-III PS – 2 nos. (6x80 MVar units)</li> <li>• 765 kV, 240 MVar SLR at Chilakaluripeta – 2 nos. (6x80 MVar units)</li> </ul>		

Package	Scope of the Transmission Scheme	Capacity /km	Schedule	Est. Cost (crs.)
B	2 nos. of 400kV line bays at Kurnool-III PS for termination of dedicated transmission line of M/s Adani Renewable Energy Forty Two Ltd.	• 400kV line bays – 2 Nos.	30.06.26	110
	4 nos. of 400kV line bay at Kurnool-III PS for termination of dedicated transmission lines of M/s Indosol Solar Pvt. Ltd.	• 400kV line bays – 1 Nos.	24 months	
		• 400kV line bays – 1 Nos.	24 months	
	• 400kV line bays – 2 Nos.	31.03.27		
	2 nos. of 400kV line bays at Kurnool-III PS for termination of dedicated transmission line of M/s Adani Renewable Energy Fifty One Ltd.	• 400kV line bays – 2 Nos.	31.12.27	
C	Augmentation of 1x1500 MVA 765/400kV ICT (7 <sup>th</sup> ) at Kurnool-III PS	<ul style="list-style-type: none"> <li>• 1x1500 MVA, 765/400kV ICT</li> <li>• 765kV ICT bay – 1 Nos.</li> <li>• 400kV ICT bay – 1 Nos.</li> </ul>	24 months	126
<b>Total</b>				<b>2886</b>

**Estimated cost : Rs. 2886 Crore**

Above transmission scheme viz., Transmission system strengthening at Kurnool-III PS for integration of additional RE generation projects has been forwarded to NCT vide CTU letter dated 30.05.2024. The scheme was discussed and agreed for implementation through TBCB route in the 20<sup>th</sup> NCT held on 25.06.2024.

**(c) Conversion of 80 MVar FLR to SLR on Vijayawada – Nellore 400kV D/c line (Line-2) at Nellore as per 44<sup>th</sup> SRPC and 42<sup>nd</sup> TCC**

POWERGRID vide letter dated 04.10.2023 informed that replacement of 50 MVar line reactor at Nellore end on Vijayawada – Nellore 400kV D/c line (Line-2) with 80 MVar under AddCap was approved in the 44<sup>th</sup> SRPC meeting held on 04.11.2022. Further, it was decided that line reactors would be made switchable for use of bus reactors wherever technically feasible / space available. Accordingly, POWERGRID requested that conversion of 80 MVar fixed line reactor at Nellore end on Vijayawada – Nellore 400kV D/c line (Line-2) to switchable line reactor along with NGR and its bypassing scheme in the CMETS-SR meeting.

Accordingly, conversion of 80 MVar fixed line reactor at Nellore end on Vijayawada – Nellore 400kV D/c line (Line-2) to switchable line reactor along with NGR and its bypassing scheme was agreed in the 32<sup>nd</sup> CMETS-SR held on 28.06.2024.

**(d) Augmentation of transformation capacity with 400/220kV, 1x500 MVA ICT (4<sup>th</sup>) at Nagarjunasagar 400/220kV substation**

The proposal for augmentation of transformation capacity with 400/220kV, 1x500 MVA ICT (4<sup>th</sup>) at Nagarjunasagar 400/220kV substation was agreed in the Joint Study meeting of SR constituents held from 2nd to 4th May, 2024 at Hyderabad. During the Joint Study meeting, it was agreed that a joint site

visit with participation from CTU, SRPC, POWERGRID, APTRANSCO and TGTRANSCO may be planned to explore the space availability for 220kV ICT bay at APTRANSCO switchyard along with interconnection with POWERGRID switchyard. Accordingly, for assessing space availability for 220kV ICT bay at Nagarjunasagar, a joint site visit was held on 24<sup>th</sup> June, 2024 comprising officials from CEA, SRPC, POWERGRID, APTRANSCO and TGTRANSCO.

During the Joint study visit 2 options were identified and could not be finalized. After detailed deliberations, it was decided that the matter may be put up to the higher forum for further deliberations and finalization.

The proposal was deliberated in the 33rd CMETS-SR held on 25.07.2024 and 31.07.2024 and after detailed deliberations, the augmentation of 1x500 MVA ICT (4<sup>th</sup>) at Nagarjunasagar was agreed. However, options for implementation of the ICT shall be finalized in the meeting with CEA.

**(e) Transmission System for integration of Kurnool-IV REZ in Andhra Pradesh**

Govt. of India has set a target of 500 GW generation capacity from non-fossil fuel resources by 2030. In this direction, MNRE has identified addition of 86 GW RE Potential in the State of Andhra Pradesh, Telangana, Karnataka and Tamil Nadu (Offshore) in Southern Region. Out of the identified (86 GW) RE Potential in Southern Region, 51 GW has been identified in the State of Andhra Pradesh (Ananthapur– 20 GW, Kurnool – 23 GW & Kadapa – 8 GW).

A comprehensive transmission system for integration of 51 GW RE Potential in Andhra Pradesh have been identified by CEA and a report on Transmission System for Integration of over 500 GW RE Capacity has been published by CEA on 07.12.2022. The details of district wise potential is as below.

District	Potential (GW)		Total (GW)	Maximum Dispatch (GW)	BESS (GW)	Evacuation System (GW)
	Wind	Solar				
Anantapur	10	10	20	15	5	10
Kurnool	8	15	23	18	6	12
Kadapa	0	8	8	8	3	5
<b>Total</b>	<b>18</b>	<b>33</b>	<b>51</b>	<b>41</b>	<b>14</b>	<b>27</b>

Presently, Connectivity of about 7740 MW (2390 MW at 220kV level & 5350 MW at 400kV level) has been granted / agreed for grant at Kurnool-III PS. Similarly, Connectivity of about 3765 MW (1055 MW at 220kV level & 2710 MW at 400kV level) has been granted / agreed for grant at Ananthapuram PS. Keeping above in view, it is prudent to take up the implementation of Kurnool-IV PS and Anantapur-II PS for integration of RE generation projects in Kurnool and Anantapur areas. The above transmission schemes were deliberated in the 28<sup>th</sup> CMETS-SR held on 29.02.2024 wherein it was decided that a physical joint study may be carried out for finalization of the transmission system for Kurnool-IV and Ananthapuram-II.

Accordingly, Joint Study meeting of Southern Region Constituents was held from 2<sup>nd</sup> to 4<sup>th</sup> May, 2024 at Hyderabad wherein following transmission system was finalized for integration of RE generation projects at Kurnool-IV in Andhra Pradesh.

**Transmission System for Integration of Kurnool-IV (Near Aspiri) REZ (for 7.5 GW)**

**Phase-I (4.5 GW)**

- Establishment of 4x1500 MVA, 765/400 & 4x500 MVA, 400/220 kV Kurnool-IV Pooling Station near Kurnool, Andhra Pradesh along with 2x330 MVAR (765 kV) bus reactors at Kurnool-IV PS (1.5 GW injection at 220 kV level and 3 GW injection at 400 kV level)
- + 300 MVAR STATCOM at Kurnool-IV, 2x125 MVAR MSR
- Kurnool-IV – Bidar 765kV D/c line (about 330 kms) with 330 MVAR SLR at both end on both circuits
- Kurnool-IV – Kurnool-III PS 765 kV D/c line (about 150 kms) with 240 MVAR SLR at Kurnool-IV end on both circuits
- Augmentation of 1x1500 MVA, 765/400 kV ICT at C’Peta

**Phase-II (3 GW)**

- Augmentation of 2x1500 MVA, 765/400 & 6x500 MVA, 400/220 kV Kurnool-IV Pooling Station (2 GW injection at 220 kV level and 2 GW injection at 400 kV level)
- Establishment of 3x1500 MVA, 765/400 kV Veltoor-II Station with 2x330 MVAR (765 kV) bus reactors
- LILO of Kurnool-IV – Bidar 765kV D/c line at Veltoor-II (about 60 kms)
- Veltoor-II – Veltoor TS 400 kV D/c (quad) line (about 60 kms)
- Veltoor-II – Udandpur 400 kV D/c (quad) line (about 30 kms)
- LILO of Vijayawada-Nellore 400 kV D/c line at C’Peta (about 20 kms)

The above transmission schemes were deliberated in the 32<sup>nd</sup> CMETS-SR held on 28.06.2024 wherein it was agreed that initially Kurnool-IV Phase-I may be taken up for implementation and Kurnool-IV Phase-II may be reviewed as per the observations of the SR constituents. It was also agreed that LILO of Vijayawada-Nellore 400 kV D/c line at C’Peta (about 20 kms) may be considered in Phase-I.

The detailed scheme is as below:

Sl. No.	Scope of the Transmission Scheme	Capacity /km
1.	<p>Establishment of 4x1500 MVA, 765/400 &amp; 4x500 MVA, 400/220 kV Kurnool-IV Pooling Station near Kurnool, Andhra Pradesh along with 2x330 MVAR (765 kV) bus reactors at Kurnool-IV PS with provision of two (2) sections of 4500 MVA each at 400kV level</p> <p><b>Future Space Provisions:</b></p> <ul style="list-style-type: none"> <li>• 765/400kV, 1500 MVA, ICTs – 2 nos.</li> <li>• 765kV ICT bays – 2 nos.</li> <li>• 400kV ICT bays – 2 nos.</li> <li>• 400/220kV, 500 MVA, ICTs – 14 nos.</li> <li>• 400kV ICT bays – 14 nos.</li> <li>• 220kV ICT bays – 14 nos.</li> <li>• 765kV line bays – 8 nos. (with provision for SLR)</li> </ul>	<ul style="list-style-type: none"> <li>• 765/400kV, 1500 MVA, ICTs – 4 nos. (13x500 MVA incl. 1 spare unit)</li> <li>• 765kV ICT bays – 4 nos.</li> <li>• 400kV ICT bays – 4 nos.</li> <li>• 400/220kV, 500 MVA, ICTs – 4 nos.</li> <li>• 400kV ICT bays – 4 nos.</li> <li>• 220kV ICT bays – 4 nos.</li> <li>• 765kV line bays – 4 nos. (at Kurnool-IV PS for termination of Kurnool-IV – Bidar and Kurnool-IV – Kurnool-III 765kV D/c lines)</li> <li>• 765 kV, 330 MVAR Bus Reactor – 2 nos.</li> <li>• 765 kV Bus Reactor bays – 2 nos.</li> <li>• 220kV line bays – 6 nos.</li> <li>• 220kV Bus Sectionalizer : 1 set</li> <li>• 220 kV Bus Coupler (BC) Bay – 2 nos.</li> </ul>

Sl. No.	Scope of the Transmission Scheme	Capacity /km
	<ul style="list-style-type: none"> <li>• 400kV line bays – 12 nos. (with provision for SLR)</li> <li>• 220kV line bays – 20 nos.</li> <li>• 220kV Bus Sectionalizer : 2 sets</li> <li>• 220 kV Bus Coupler (BC) Bay – 2 nos.</li> <li>• 220 kV Transfer Bus Coupler (TBC) Bay – 2 nos.</li> <li>• 400kV Bus Sectionalizer : 1 set</li> </ul>	<ul style="list-style-type: none"> <li>• 220 kV Transfer Bus Coupler (TBC) Bay – 2 nos.</li> </ul>
2.	Kurnool-IV – Bidar 765kV D/c line (about 330 kms) with 330 MVAR SLR (convertible) at both ends on both circuits	<p style="text-align: center;">~ 330 km</p> <ul style="list-style-type: none"> <li>• 765kV line bays – 2 nos. (at Bidar PS)</li> <li>• 765 kV, 330 MVar SLR at Kurnool-IV PS – 2 nos. (7x110 MVar inc. 1 switchable spare unit for both bus reactor and line reactor)</li> <li>• 765 kV, 330 MVar SLR at Bidar PS – 2 nos. (7x110 MVar inc. 1 switchable spare unit )</li> </ul>
3.	Kurnool-IV – Kurnool-III PS 765 kV D/c line (about 150 kms) with 240 MVAR SLR (convertible) at Kurnool-IV end on both circuits	<p style="text-align: center;">~ 150 km</p> <ul style="list-style-type: none"> <li>• 765kV line bays – 2 nos. (at Kurnool-III PS)</li> <li>• 765 kV, 240 MVar SLR at Kurnool-IV PS – 2 nos. (7x80 MVar inc. 1 switchable spare unit)</li> </ul>
4.	$\pm$ 300 MVAR STATCOM at Kurnool-IV PS along with 2x125 MVar MSR	<ul style="list-style-type: none"> <li>• 400 kV bay – 1 no.</li> </ul>
5.	Augmentation of 1x1500 MVA, 765/400 kV ICT (3 <sup>rd</sup> ) at C’Peta	<ul style="list-style-type: none"> <li>• 765/400kV, 1500 MVA, ICT – 1 no.</li> <li>• 765kV ICT bays – 1 no.</li> <li>• 400kV ICT bays – 1 no.</li> </ul>
6.	LILO of Vijayawada-Nellore 400 kV D/c line at C’Peta (about 20 kms)	<p style="text-align: center;">~ 20 km</p> <ul style="list-style-type: none"> <li>• 400kV line bays – 4 nos. (at C’Peta for termination of LILO of Vijayawada-Nellore 400 kV D/c line at C’Peta)</li> </ul>

**Estimated Cost : Rs. 5550 Crs**

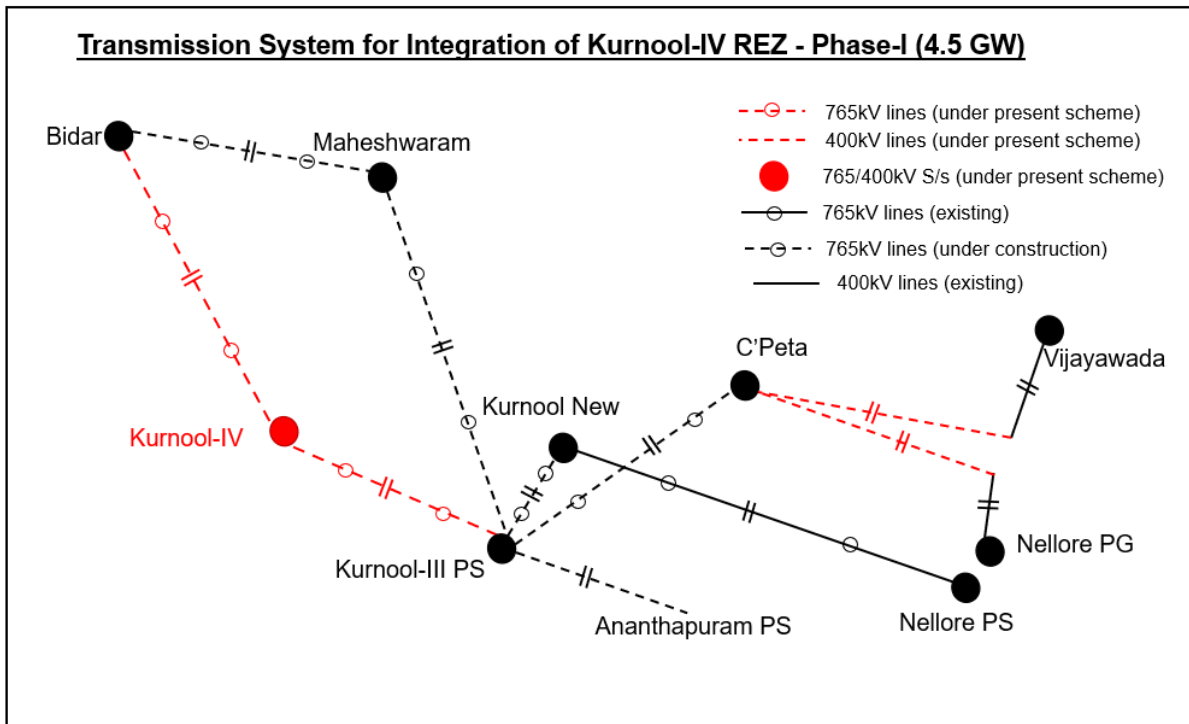

The above transmission scheme has been forwarded to NCT vide CTU letter dated 17.08.2024.

**(f) Transmission System for integration of Anantapur-II REZ in Andhra Pradesh**

**Phase-I (4.5 GW)**

- Establishment of 4x1500 MVA, 765/400 kV & 4x500 MVA, 400/220 kV Anantapur-II Pooling Station near Kurnool, Andhra Pradesh along with 2x330 MVAR (765 kV) bus reactors at Anantapur-II PS (1.5 GW injection at 220 kV level and 2.5 GW injection at 400 kV level)
- + 300 MVAR STATCOM at Ananthpur-II, 2x125 MVAR MSR
- Anantapur-II – Davangere 765kV D/c line (about 150km) with 240 MVAR SLR at Anatpur-II end on both circuits
- Anantapur-II – Cuddapah 765kV D/c line (about 200km) with 330 MVAR SLR at Anatpur-II end on both circuits

**Phase-II (3.5 GW)**

- Augmentation of 2x1500 MVA, 765/400 & 6x500 MVA, 400/220 kV Kurnool-IV Pooling Station (2.5 GW injection at 220 kV level and 2 GW injection at 400 kV level)
- Establishment of 3x1500 MVA, 765/400 kV CN'Halli Station along with 2x330 MVAR (765 kV) bus reactors
- Anantapur-II – CN'Halli 765kV D/c line (about 180km) with 330 MVAR SLR at Anatpur-II end on both circuits
- CN'Halli - CN'Halli (KPTCL) 400 kV (quad) D/c line (about 10km)

The above transmission schemes were deliberated in the 32<sup>nd</sup> CMETS-SR held on 28.06.2024 wherein it was agreed that initially Ananthapuram-II Phase-I may be taken up for implementation and Ananthapuram-II Phase-II may be reviewed as per the observations of the SR constituents.

The detailed scheme is as below:

Sl. No.	Scope of the Transmission Scheme	Capacity /km
1.	<p>Establishment of 4x1500 MVA, 765/400 &amp; 4x500 MVA, 400/220 kV Ananthapuram-II Pooling Station near Kurnool, Andhra Pradesh along with 2x330 MVAr (765 kV) bus reactors at Ananthapuram-II PS with provision of two (2) sections of 4500 MVA each at 400kV level</p> <p><b>Future Space Provisions:</b></p> <ul style="list-style-type: none"> <li>• 765/400kV, 1500 MVA, ICTs – 2 nos.</li> <li>• 765kV ICT bays – 2 nos.</li> <li>• 400kV ICT bays – 2 nos.</li> <li>• 400/220kV, 500 MVA, ICTs – 14 nos.</li> <li>• 400kV ICT bays – 14 nos.</li> <li>• 220kV ICT bays – 14 nos.</li> <li>• 765kV line bays – 8 nos. (with provision for SLR)</li> <li>• 400kV line bays – 12 nos. (with provision for SLR)</li> <li>• 220kV line bays – 20 nos.</li> <li>• 220kV Bus Sectionalizer : 2 sets</li> <li>• 220 kV Bus Coupler (BC) Bay – 2 nos.</li> <li>• 220 kV Transfer Bus Coupler (TBC) Bay – 2 nos.</li> <li>• 400kV Bus Sectionalizer : 1 set</li> </ul>	<ul style="list-style-type: none"> <li>• 765/400kV, 1500 MVA, ICTs – 4 nos. (13x500 MVA incl. 1 spare unit)</li> <li>• 765kV ICT bays – 4 nos.</li> <li>• 400kV ICT bays – 4 nos.</li> <li>• 400/220kV, 500 MVA, ICTs – 4 nos.</li> <li>• 400kV ICT bays – 4 nos.</li> <li>• 220kV ICT bays – 4 nos.</li> <li>• 765kV line bays – 4 nos. (at Ananthapuram-II PS for termination of Ananthapuram-II – Davanagere and Ananthapuram-II – Cuddapah 765kV D/c lines)</li> <li>• 765 kV, 330 MVAr Bus Reactor – 2 nos.</li> <li>• 765 kV Bus Reactor bays – 2 nos.</li> <li>• 220kV line bays – 6 nos.</li> <li>• 220kV Bus Sectionalizer : 1 set</li> <li>• 220 kV Bus Coupler (BC) Bay – 2 no.</li> <li>• 220 kV Transfer Bus Coupler (TBC) Bay – 2 no.</li> </ul>
2.	Ananthapuram-II – Davanagere 765kV D/c line (about 150km) with 240 MVAR SLR (convertible) at Ananthapuram-II end on both circuits	<p style="text-align: center;">~ 150 km</p> <ul style="list-style-type: none"> <li>• 765kV line bays – 2 nos. (at Davanagere PS)</li> <li>• 765 kV, 240 MVAr SLR at Ananthapuram-II PS – 2 nos. (7x80 MVAr inc. 1 switchable spare unit)</li> </ul>
3.	Ananthapuram-II – Cuddapah 765kV D/c line (about 200km) with 330 MVAR SLR (convertible) at Ananthapuram-II end on both circuits	<p style="text-align: center;">~ 200 km</p> <ul style="list-style-type: none"> <li>• 765kV line bays – 2 nos. (at Cuddapah)</li> <li>• 765 kV, 330 MVAr SLR at Ananthapuram-II PS – 2 nos. (7x110 MVAr inc. 1 switchable spare unit for both bus reactor and line reactor)</li> </ul>
4.	± 300 MVAR STATCOM at Ananthapuram-II PS along with 2x125 MVAr MSR	<ul style="list-style-type: none"> <li>• 400 kV bay – 1 no.</li> </ul>

**Estimated Cost : Rs. 4577 Crs**

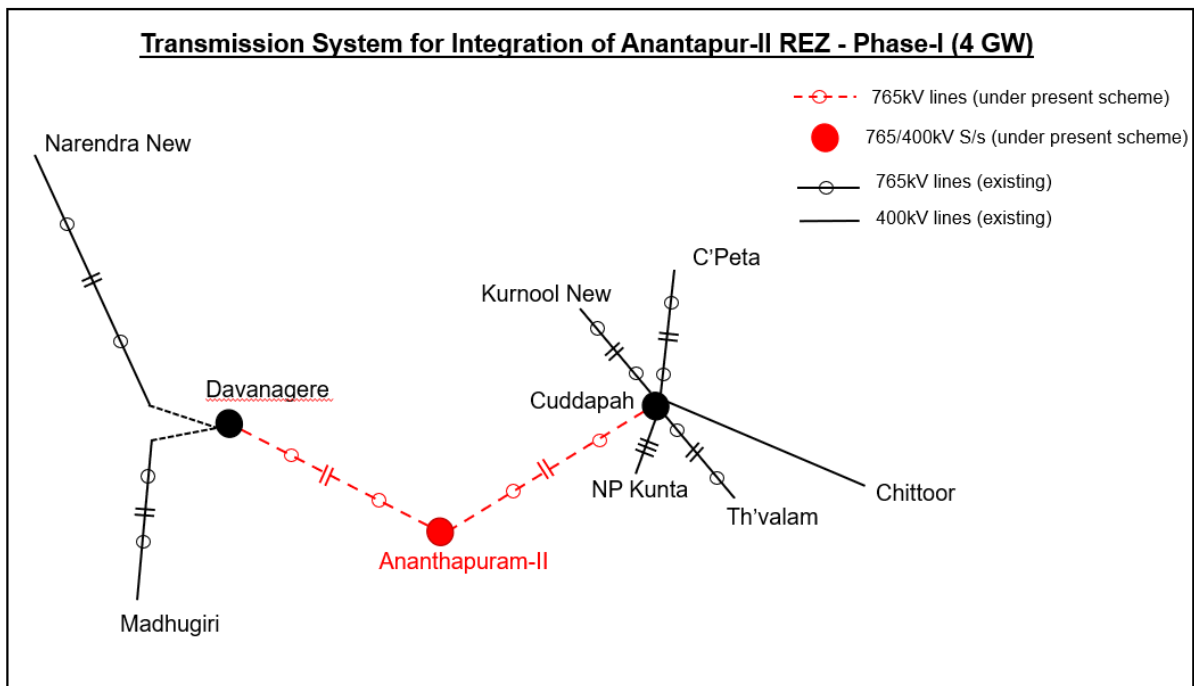

The above transmission scheme has been forwarded to NCT vide CTU letter dated 17.08.2024.

**(g) Transmission System for proposed Green Hydrogen / Green Ammonia projects in Kakinada area, Andhra Pradesh**

Govt. of India has set a CTU informed that a meeting was held on 19.10.2023 chaired by Hon’ble Minister with Green Hydrogen stakeholders/association, wherein it was instructed that developers shall share the details of year-wise planned Green Ammonia / Green Methanol capacities and corresponding drawl capacities desired at different locations. Hon’ble minister also instructed that this information should be shared with CTU for planning the required substation capacities at these specified locations. MNRE vide letter dated 01.11.2023 has forwarded the consolidated information of the planned projects and drawl requirements of various developers.

Subsequently, CEA convened a meeting with Green Hydrogen/ Green Ammonia manufacturers to access the year wise electricity demand for proper planning of transmission system. In Kakinada area, about 6000 MW demand has been envisaged for the Green Hydrogen/ Green Ammonia projects. The details of the phased development are as follows

Year	Cumulative Electricity Demand (MW)
by 2027	1775
by 2028	3275
by 2029	4645
by 2030	6015

CTU has already received application from M/s AM Green Ammonia (India) Pvt. Ltd. seeking GNA-RE for 700 MW as Bulk Consumer in Kakinada area. The application is under discussion for grant of GNA in CMETS meeting. Further AM Green Ammonia (India) Private Limited vide email dated

20.01.2024 has indicated that they are in the process of developing a 2 MPTA Green Ammonia Project in Kakinada, Andhra Pradesh in phased manner. The total drawl requirement for the entire Green Ammonia Kakinada project capacity is 3370 MW. The details of the phased development are as follows

Year	Electricity Demand (MW)
Phase I	700
Phase II	700
Phase III	1300
Phase IV	660

Further, application has also been received from M/s AM Green Ammonia (India) Pvt. Ltd. for additional 1300 MW in the month of July 2024, seeking GNA-RE for additional 1300 MW as Bulk Consumer for Green Hydrogen loads in Kakinada area.

In view of the upcoming Green Hydrogen / Green Ammonia plants / industries, planning of transmission system has been done for delivery of power to Green Hydrogen / Ammonia manufacturing projects at Kakinada in Andhra Pradesh. Upon discussions between CTU and CEA, following transmission system identified for supply of power to Green Hydrogen / Ammonia projects at Kakinada was deliberated in the 33<sup>rd</sup> CMETS-SR held on 25.07.2024

**Transmission system for proposed Green Hydrogen / Green Ammonia projects in Kakinada area**

**Phase-I : 3000 MW**

- Establishment of Kakinada 765/400 kV, 3x1500 MVA substation
- LILO of Vemagiri – Srikakulam 765 kV D/c line at Kakinada substation

Note \* : Angul – Srikakulam 765 kV 2<sup>nd</sup> D/c line shall be required which is to be taken up for enhancement of TTC/ATC

**Phase-II : Cumulative 6000 MW**

- Augmentation by 3x1500 MVA, 765/400 kV ICTs at Kakinada substation
- Establishment of Khammam-II 765/400 kV, 3x1500 MVA substation
- Warangal – Khammam-II 765 kV D/c line
- Khammam-II – Vemagiri 765 kV D/c line
- Khammam-II – Khamman (exisiting) 400 kV D/c (quad) line
- Vemagiri – Kakinada 765 kV 2<sup>nd</sup> D/c line

During the meeting, CTU informed that the proposed Phase-I Transmission system for Green Hydrogen / Green Ammonia projects in Kakinada area shall be required for immediate integration and supply of power to these projects irrespective of other transmission system strengthening including HVDC system. Further, CTU has already received applications from Green Hydrogen / Green Ammonia projects for 2000 MW which is to be disposed of in time bound manner in accordance with the CERC GNA Regulations, 2022. Accordingly, Transmission system for proposed Green Hydrogen / Green Ammonia projects in Kakinada area, Andhra Pradesh (Phase-I) may be put up for formal approval and

the balance Phase-II transmission system and HVDC proposal may be submitted to SRPC for further deliberations alongwith the inter-regional links studied during the Joint Study meeting.

After detailed deliberations, the proposal for “Transmission system for proposed Green Hydrogen / Green Ammonia projects in Kakinada area, Andhra Pradesh (Phase-I)” was discussed and agreed in the 33<sup>rd</sup> CMETS-SR held on 25.07.2024, the details of the transmission scheme are as below:

**Transmission system for proposed Green Hydrogen / Green Ammonia projects in Kakinada area (Phase-I)**

- Establishment of Kakinada 765/400 kV, 3x1500 MVA substation alongwith bus reactor
- LILO of Vemagiri – Srikakulam 765 kV D/c line at Kakinada substation

Note \* : Angul – Srikakulam 765 kV 2<sup>nd</sup> D/c line shall be required which is to be taken up for enhancement of TTC / ATC

**Estimated Cost : Rs. 1015 Crs**

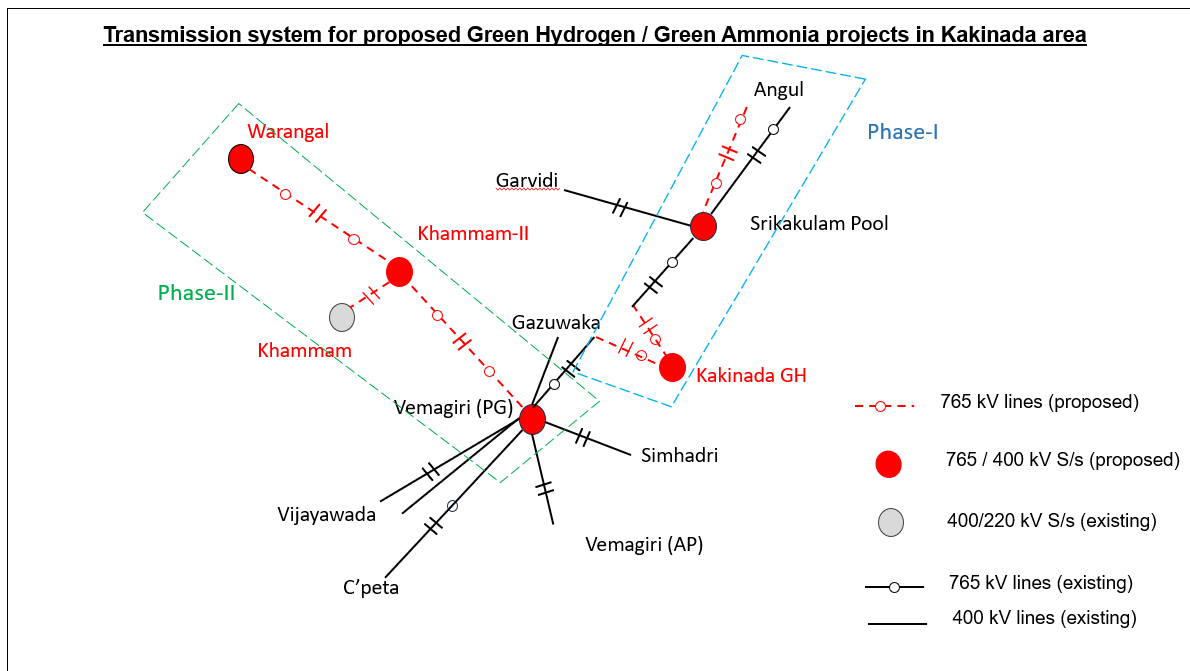

**(h) Augmentation of transformation capacity by 2x500 MVA, 400/220kV ICTs (5<sup>th</sup> & 6<sup>th</sup>) at Anantapuram-II PS**

Presently, CTU informed that establishment of 4x1500 MVA, 765/400 kV & 4x500 MVA, 400/220 kV Anantapuram-II Pooling Station near Kurnool, Andhra Pradesh was agreed in 32<sup>nd</sup> CMETS-SR held on 28.06.2024. The transmission scheme has been submitted to SRPC for its views and subsequently shall be submitted to NCT along with SRPC views. Total Connectivity already granted / agreed for grant at Anantapuram-II PS is 1689.7 MW. Further, connectivity corresponding to 800 MW has been received. Therefore, total connectivity granted / agreed for grant / under consideration shall be 2489.7 MW. Accordingly, for grant of connectivity (considering N-1 contingency criteria) augmentation of 2x500 MVA, 400/220 kV (5<sup>th</sup> & 6<sup>th</sup>) ICTs at Anantapuram-II PS is required.

Accordingly, augmentation of transformation capacity by 2x500 MVA, 400/220 kV ICTs (5<sup>th</sup> & 6<sup>th</sup>) at Anantapuram-II PS in Andhra Pradesh was discussed and agreed in the 33<sup>rd</sup> CMETS-SR held on 25.07.2024

**Estimated cost : Rs. 102 Crs**

## 5.2 Karnataka

### (a) Augmentation of transformation capacity by 1x500 MVA (3<sup>rd</sup>), 400/220kV ICT at Yelahanka 400/220kV GIS S/s in Karnataka

Presently, 2x500 MVA, 400/220kV are existing at Yelahanka GIS. KPTCL vide letter dated 28.03.2024 has communicated that residential load of about 250 MW is coming up at Dr. Shivaram Karanath BDA layout near Ganigarahalli in Bengaluru. KPTCL is proposing to establish a new 220kV substation in that area by interconnecting with Yelahanka 400/220kV GIS S/s through 1200sqmm UG cable for meeting the demand. Keeping in view of the upcoming 250 MW load, KPTCL opined that additional 1x500 MVA, 400/220kV ICT (3<sup>rd</sup>) at Yelahanka GIS is required considering the N-1 contingency criteria. Accordingly, they had requested for augmentation of 1x500 MVA (3<sup>rd</sup>), 400/220kV ICT at Yelahanka 400/220kV GIS S/s.

Accordingly, augmentation of transformation capacity by 1x500 MVA (3<sup>rd</sup>), 400/220kV ICT at Yelahanka 400/220kV GIS S/s was discussed and agreed in the 32<sup>nd</sup> CMETS-SR held on 28.06.2024.

**Estimated Cost : Rs. 52 Crore**

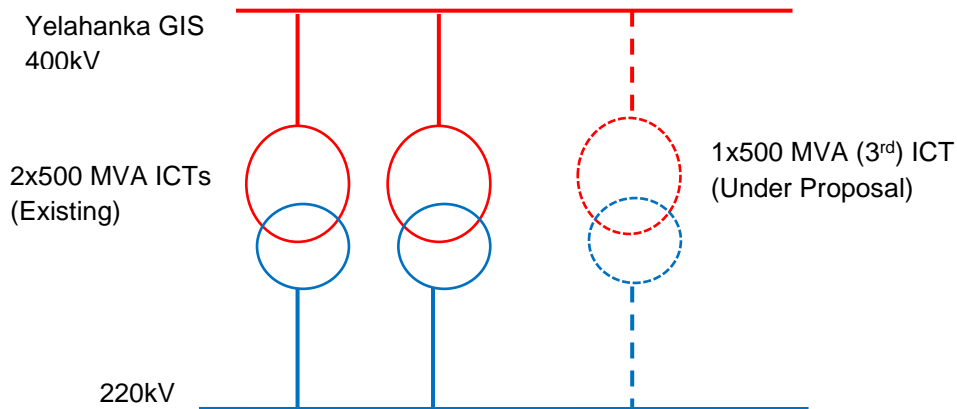

Figure : Schematic of 400/220 kV Yelahanka GIS S/s

### (b) Augmentation of transformation capacity by 2x500 MVA (9<sup>th</sup> & 10<sup>th</sup>), 400/220kV ICTs at Tumkur (Pavagada) 400/220kV Pooling Station in Karnataka and Implementation of 1 nos. of 220kV line bay at Tumkur (Pavagada) 400/220kV PS for providing Connectivity to RE generation project

Presently, Tumkur (Pavagada) PS is under operation with 6x500 MVA, 400/220kV ICTs and 2x500 MVA (7<sup>th</sup> & 8<sup>th</sup>), 400/220kV ICTs at Tumkur (Pavagada) are under implementation and expected by Aug'25. The Connectivity of 3350 MW has been granted to RE projects at Tumkur (Pavagada) PS.

During the 25<sup>th</sup> CMETS-SR held on 28.11.2023, Connectivity of 200 MW has been agreed for grant to M/s TEQ Green Power XVIII Pvt. Ltd. at 220kV level with 1 nos. of 220kV bay. The above applicant have requested for implementation of 220kV bay at Tumkur (Pavagada) PS under ISTS with start date as 30.06.2026. The same was also agreed in the 28<sup>th</sup> CMETS-SR held on 29.02.2024. Further, M/s KSPDCL has submitted application for enhancement of Connectivity for 300 MW at Tumkur (Pavagada) PS (from under operation 2050 MW solar project to 2350 MW) as Renewable Power Park Developer which was discussed in the 26<sup>th</sup> CMETS-SR held on 29.12.2023. During the meeting, it was decided that due to non-availability of margins for grant of additional connectivity at Tumkur (Pavagada) PS, the connectivity has been granted at Tumkur-II PS.

In 26<sup>th</sup> CMETS-SR, KSPDCL mentioned that they have taken initiatives towards acquisition of land for augmentation of Tumkur (Pavagada) PS and requested for grant of connectivity for 300 MW at Tumkur (Pavagada PS) instead of Tumkur-II PS. CTU informed that at present, for grant of connectivity, there is no margin in existing Tumkur (Pavagada) PS. After getting confirmation towards land acquisition and possibility of Tumkur (Pavagada) PS augmentation, the same shall be considered for grant of connectivity. KSPDCL vide letter dated 31.05.2024 informed that they have initiated few actions subsequent to the 26<sup>th</sup> CMETS-SR meeting viz. identification of land required for proposed expansion and fixation of land rate by Deputy Commissioner, consent from the farmers to sell the land etc.

Accordingly, as land is available for expansion of the pooling station and for optimal utilization of the transmission system, augmentation of transformation capacity by 2x500 MVA (9<sup>th</sup> & 10<sup>th</sup>), 400/220kV ICTs at Tumkur (Pavagada) 400/220kV Pooling Station in Karnataka was discussed and agreed in the 32<sup>nd</sup> CMETS-SR held on 28.06.2024. The details of the scheme is as below:

Sl. No.	Scope of the Transmission Scheme	Capacity /km	Schedule	Est. Cost (crs.)
1	Augmentation of transformation capacity by 2x500 MVA (9 <sup>th</sup> & 10 <sup>th</sup> ), 400/220kV ICTs at Tumkur (Pavagada) 400/220kV Pooling Station	<ul style="list-style-type: none"> <li>• 2x500 MVA, 400/220kV ICTs</li> <li>• 400kV ICT bay – 2 Nos.</li> <li>• 220kV ICT bay – 2 Nos.</li> </ul>	21 months	112
2	Additional land of about 100 m (width) x 540 m (length) on right side of the Tumkur (Pavagada) PS for expansion of Tumkur (Pavagada) PS with 2 nos. of additional 500 MVA ICTs & 220 kV line bays	The total land of about 13 Acres 22 Guntas is required for the proposed expansion and land rate has been fixed by the Deputy Commissioner at Rs. 2.62 Cr. (Rs. 19.35 L per Acre) as communicated by KSPDCL vide letter dated 31.05.2024		
3	Implementation of 1 nos. of 220kV line bay at Tumkur(Pavagada) 400/220kV PS for providing Connectivity to RE generation project	1 no. 220kV line bay at Tumkur(Pavagada) 400/220kV PS for termination of dedicated line of M/s TEQ Green Power XVIII Pvt. Ltd.	30.06.26	6
			<b>Total</b>	<b>118</b>

**Estimated Cost: Rs. 118 Crore**

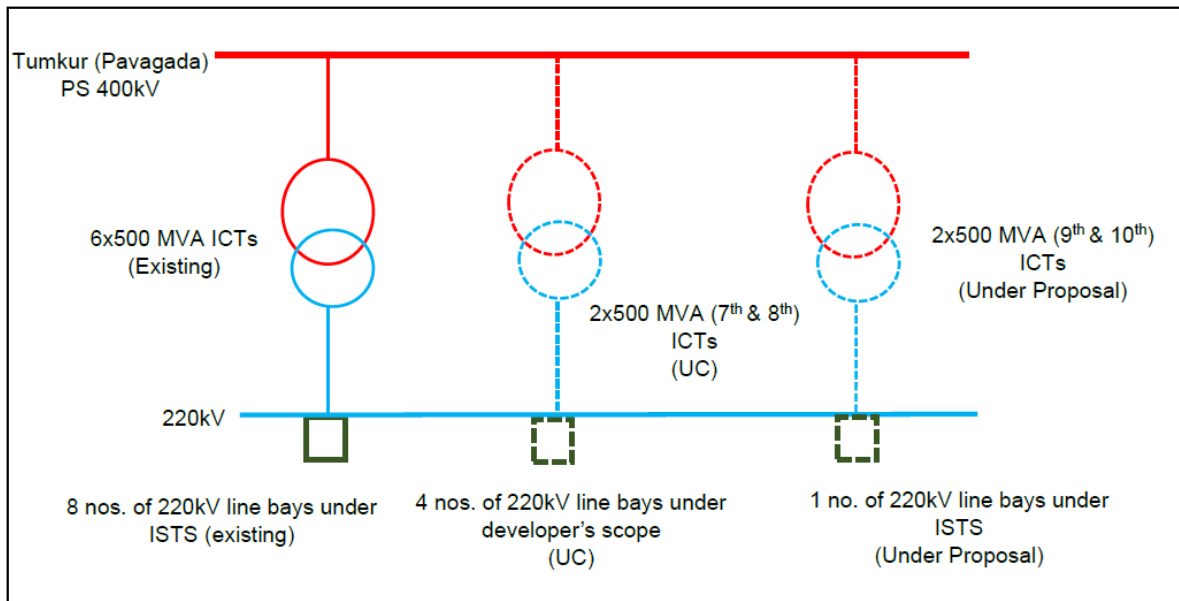

Figure : Schematic of 400/220 kV Tumkur(Pavagada) PS

Above transmission scheme has been forwarded to NCT vide CTU letter dated 26.07.2024. The scheme was discussed and agreed for implementation under RTM route with implementation schedule of 21 months in the 21<sup>st</sup> NCT held on 06.08.2024.

**(c) Augmentation of transformation capacity by 1x500 MVA (3<sup>rd</sup>), 400/220kV ICT at Bidadi S/s in Karnataka**

During the 213<sup>th</sup> OCC meeting of SRPC held on 10.04.2024 requirement of additional ICT at Bidadi S/s due to continuous overloading / N-1 violation of existing ICTs was discussed. During the meeting it was opined that KPTCL have to plan / augment the downstream network to match the power evacuation. The matter was also deliberated during the 216<sup>th</sup> OCC meeting of SRPC held on 10.07.2024, wherein it was decided that matter may be taken up in the next CMETS-SR meeting for deliberations.

Accordingly, augmentation of transformation capacity by 1x500 MVA (3<sup>rd</sup>), 400/220kV ICT at Bidadi S/s in Karnataka was discussed and agreed in the 33<sup>rd</sup> CMETS-SR held on 25.07.2024.

**(d) Augmentation of transformation capacity by 4x500 MVA, 400/220kV ICTs (5<sup>th</sup> – 8<sup>th</sup>) at Davanagere PS**

Presently, 4x1500 MVA, 765/400kV and 4x500 MVA, 400/220 kV Davanagere / Chitradurga Pooling Station is being established as part of ‘Transmission system for integration of Davanagere/ Chitradurga REZ’. The transmission scheme has been recommended for implementation through TBCB route in the 18th NCT held on 05.03.2024 and Gazette Notification published on 15.03.2024 by Ministry of Power with implementation time frame of 24 months. Considering the bidding process timeline, the scheme is expected tentatively by July/Aug’2026. Total Connectivity already granted/ agreed for grant at Davanagere PS is 2340 MW. Therefore, in 32<sup>nd</sup> CMETS-SR, held on 28.06.2024, for grant of Connectivity, augmentation of 2x500 MVA, 400/230 kV (5<sup>th</sup> & 6<sup>th</sup>) ICT were proposed and same was agreed. Subsequently, applications for additional connectivity corresponding to 775 MW capacity has been received upto June 2024. Therefore, total connectivity granted/ agreed for grant/ under consideration shall be 3115 MW. Accordingly, total 8x500 MVA, 400/220 kV transformation capacity is required at Davanagere PS for grant of connectivity for 3115 MW (considering N-1 contingency criteria).

Accordingly, augmentation of transformation capacity by 4x500 MVA, 400/220 kV ICTs (5<sup>th</sup> – 8<sup>th</sup>) at Davanagere PS in Karnataka was discussed and agreed in the 33<sup>rd</sup> CMETS-SR held on 25.07.2024

**Estimated cost : Rs. 204 crs**

**(e) Augmentation of transformation capacity by 3x500 MVA, 400/220kV ICTs (6<sup>th</sup> - 8<sup>th</sup>) and 1x1500 MVA,765/400kV ICT (4<sup>th</sup>) at Bidar PS**

CTU informed that Bidar PS is being established with 3x1500 MVA, 765/400kV and 5x500 MVA, 400/220 kV ICTs as part of ‘Transmission Scheme for Solar Energy Zone in Bidar (2500 MW), Karnataka’. Details of transmission system as per Annexure-V. The transmission scheme is under implementation and expected by 09.02.2026. Total Connectivity already granted / agreed for grant at Bidar PS is 2500 MW. Therefore, in 32<sup>nd</sup> CMETS-SR, held on 28.06.2024, CTU informed that for grant of Connectivity, augmentation of 1x500 MVA, 400/220 kV (6<sup>th</sup>) ICT is required and same was agreed. Subsequently, applications for additional connectivity corresponding to 600 MW capacity has been received upto June 2024. Therefore, total connectivity granted / agreed for grant / under consideration shall be 3100 MW. Accordingly, for grant of connectivity (considering N-1 contingency criteria) total 8x500 MVA, 400/220kV and 4x1500 765/400kV ICTs shall be required at Bidar PS.

Accordingly, augmentation of transformation capacity by 3x500 MVA, 400/220 kV ICTs (6<sup>th</sup> – 8<sup>th</sup>) and 1x1500 765/400kV ICT (4<sup>th</sup>) at Bidar PS in Karnataka was discussed and agreed in the 33<sup>rd</sup> CMETS-SR held on 25.07.2024.

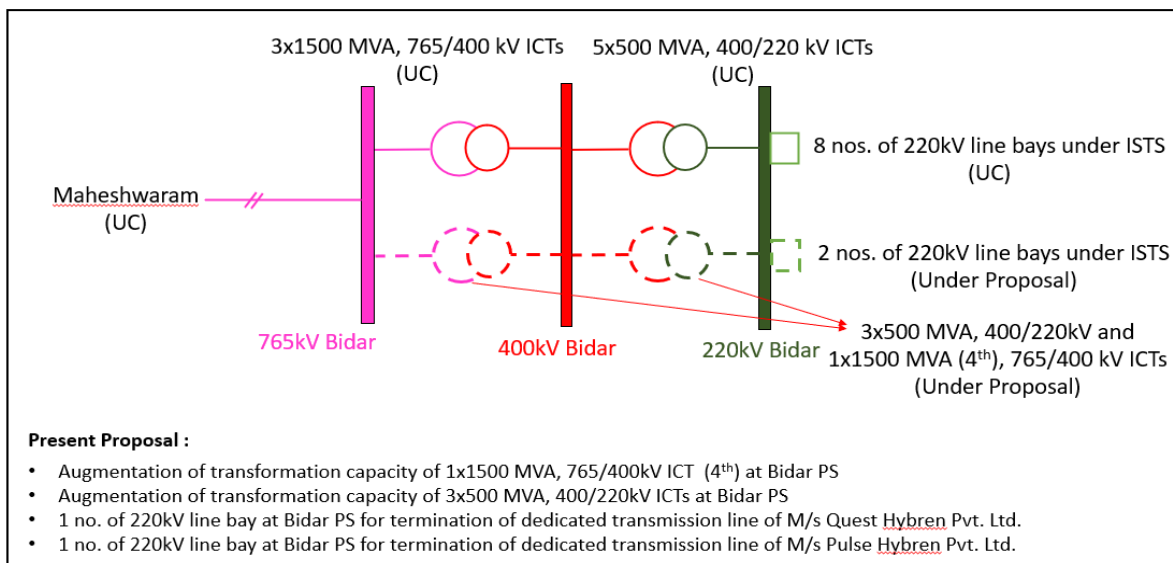

**Estimated cost : Rs. 288 crs.**

Above transmission scheme has been forwarded to NCT vide CTU letter dated 20.08.2024.

### 5.3 Tamil Nadu

**(a) Transmission System for 1 GW Offshore wind farm (Phase-I) in Tamil Nadu**

Govt. of India has set a target of 500 GW capacity addition from non-fossil fuel based generation capacity by 2030. MNRE has identified about 30 GW Offshore wind potential each in the coast of Gujarat and Tamil Nadu. A report on Transmission System for Integration of over 500 GW RE Capacity has been published by CEA on 07.12.2022 wherein initially 5 GW Offshore wind potential each at Gujarat (CUF – 37%) and Tamil Nadu (CUF – 48%) has been prioritized for implementation by 2030.

Further, a meeting on “Offshore development” was held under chairmanship of Shri R.K. Singh, Hon’ble Minister of Power and New & Renewable Energy on 14.06.2023, to discuss the issues related to grid connection, timelines and bidding of offshore wind energy projects under various models. During the meeting, it was decided that initially 2GW offshore evacuation infrastructure (1 GW in Gujarat and 1 GW in Tamil Nadu) may be developed by PGCIL under RTM and further 4GW evacuation infrastructure will be developed under TBCB. Same was also decided in the meeting held on 16.08.2023 between MNRE & CTUIL. Further, in the meeting held on 22.12.2023 in MNRE for finalization of the specifications of the transmission infrastructure, it was decided that 500 MW VGF project off-Tamil Nadu coast to be commissioned by March 2029 for which tender shall be published by March 2025. Further, 4 GW non-VGF project off-Tamil Nadu coast to be commissioned by in FY 029-30 for which tender are to be published on 01.02.2024.

The transmission system for the 1 GW Offshore wind generation in Tamil Nadu was deliberated during the 28<sup>th</sup> CMETS meeting held on 29.02.2024 and was forwarded to SRPC for views on 05.03.2024 and same was deliberated in the 50<sup>th</sup> SRPC meeting held on 16.03.2024. SRPC vide letter dated 18.04.2024 has forwarded the views of Southern Region constituents.

The transmission system was discussed in the 20<sup>th</sup> NCT meeting held on 25.06.2024. During the 20<sup>th</sup> NCT meeting, based on the inputs from MNRE, it was decided that initially transmission system for 500 MW VGF offshore wind generation project may be taken up for implementation. The details of the transmission system is as below:

**A. Transmission System onwards Onshore Pooling Station**

- Establishment of 2x500 MVA, 400/230 kV Onshore Pooling Station near Avaraikulam, Tirunelveli District in Tamil Nadu with provision of expansion upto 5 GW.
- Avaraikulam Onshore PS – Tuticorin PS 400 kV D/c quad line (approx. 100 km)
- $\pm$  300 MVar STATCOM along with 2x125 MVar MSR

**Estimated Cost : Rs. 1096 Crs**

**B. Transmission System for integration of Offshore Wind Farms with Onshore PS**

**Offshore Substation-1 {500 MW VGF} :**

- Establishment of 2x315 MVA, 230/66kV Off-Shore Substation-1 with 10 nos. of 66kV line bays for RE integration
- Offshore substation 1 (OSS-1) – Avaraikulam Onshore PS 2 nos. 230kV (atleast 300 MVA capacity) Submarine cables (~35 - 40 km) with 2x50MVar switchable line reactors at OSS-1 end

**Estimated Cost : Rs. 5146 Crs**

**Total Estimated Cost : Rs. 6242 Crs**



**(b) Implementation of 1 nos. of 230kV line bay at Karur 400/230kV PS for integration of RE generation project (M/s Nannai Solar Park Private Ltd.)**

Presently, Karur 400/230kV PS is under operation with 2x500 MVA, 400/230kV ICTs and 2x500 MVA, 400/230kV ICTs (3<sup>rd</sup> & 4<sup>th</sup>) are under implementation and expected commissioning schedule is 11.09.2025. During the 30<sup>th</sup> CMETS-SR held on 30.04.2024, Connectivity of 93 MW has been agreed for grant to M/s Nannai Solar Park Private Ltd. at 230kV level with 1 nos. of 230kV line bay. The applicant has requested for implementation of 230kV bay at Karur PS under ISTS and same was agreed. The details are as below:

Sl. No.	Description of Transmission Element	Scope of work	Schedule
1	1 no. 230kV line bay at Karur 400/230kV PS for termination of dedicated line of M/s Nannai Solar Park Private Ltd.	230kV line bays – 1 Nos.	30.09.25

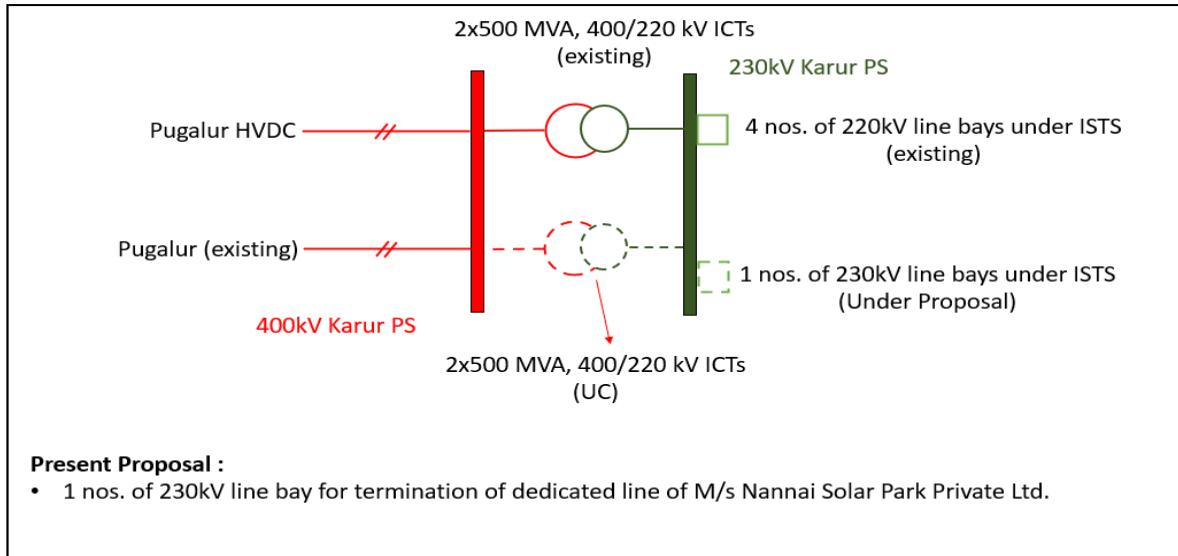

**Estimated cost : Rs. 6 Crore**

**(c) Transmission system for proposed Green Hydrogen / Green Ammonia projects in Tuticorin area.**

A meeting was held on 19.10.2023 chaired by Hon’ble Minister of Power and NRE with Green Hydrogen stakeholders/association, wherein it was decided that developers shall share the details of year-wise planned Green Ammonia / Green Methanol capacities and corresponding drawl capacities desired at different locations. It was also decided that this information should be shared with CTU for planning the required substation capacities at these specified locations. MNRE vide letter dated 01.11.2023 has forwarded the consolidated information of the planned projects and drawl requirements of various developers.

Subsequently, CEA convened a meeting with Green Hydrogen / Green Ammonia manufacturers to access the year wise electricity demand for proper planning of transmission system. In Tuticorin area, about 7000 MW demand has been envisaged for the Green Hydrogen / Green Ammonia projects. The details of the phased development are as follows:

Year	Cumulative Demand (MW)	Electricity
By 2027	2900	
By 2028	2900	
By 2029	5645	
By 2030	7015	

In view of the upcoming Green Hydrogen / Green Ammonia projects, transmission system has been identified for delivery of power to the potential Green Hydrogen / Green Ammonia projects. After discussion, CEA & CTU identified following transmission system for supply of power at Tuticorin to potential Green Hydrogen / Green Ammonia projects :

**Proposed Transmission network:**

- Establishment of Tuticorin (GH) 765/400 kV, 3x1500 MVA S/s with 1x240 MVAR Bus Reactor.

- Tuticorin Pool – Tuticorin (GH) 765 kV D/c line.
- Upgradation of 765 kV Tuticorin Pool (presently charged at 400 kV) to its rated voltage at 765 kV.
- Upgradation of 765 kV Dharmapuri (presently charged at 400 kV) to its rated voltage at 765 kV.
- Upgradation of Tuticorin Pool – Dharmapuri 765 kV line (presently charged at 400 kV) to its rated voltage at 765 kV.
- Upgradation of Dharmapuri – Madhugiri 765 kV line (presently charged at 400 kV) to its rated voltage at 765 kV

In the meanwhile, application under GNA Regulations has been received from M/s AM Green Ammonia (India) Pvt. Ltd. in Feb, 2024 seeking grant of GNA-RE as Bulk Consumer for 1660 MW as per below details :

Name of the Applicant	GNA (Within & outside region)	Nature of Applicant	Location details of GNA (requested)	Start date of GNA (requested)	End date of GNA (requested)
AM Green Ammonia (India) Pvt. Ltd.	Within Region: 0 MW Outside Region: 1660MW	Bulk consumer seeking to connect to ISTS	Tuticorin PS	01.12.2026	30.11.2051

M/s AM Green Ammonia (India) Pvt. Ltd. has indicated that they are in the process of developing Green Ammonia Plant in phased manner. The total drawl requirement for the entire Green Ammonia Tuticorin project capacity shall be 2260 MW. The application was discussed in the 31<sup>st</sup> CMETS-SR, held on 30.05.2024 wherein it was decided that GNA-RE may be granted to M/s AM Green Ammonia (India) Pvt. Ltd. at Tuticorin for production of Green Hydrogen / Green Ammonia through following transmission scheme:

- Establishment of 3x1500 MVA, 765/400 kV Tuticorin (GH) project with 1x240 MVAR bus Reactor.
- Tuticorin Pool – Tuticorin (GH) 765 kV D/c line.
- Upgradation of 765 kV Tuticorin Pool (presently charged at 400 kV) to its rated voltage at 765 kV along with 3x1500 MVA, 765/400 kV ICTs and 1x330 MVAR bus Reactor.
- Upgradation of 765 kV Dharmapuri (presently charged at 400 kV) to its rated voltage at 765 kV along with 3x1500 MVA, 765/400 kV ICTs and 1x330 MVAR bus Reactor.
- Upgradation of Tuticorin Pool – Dharmapuri 765 kV line (presently charged at 400 kV) to its rated voltage at 765 kV alongwith 1x330 MVAR Switchable Line Reactor at both end of each circuit.
- Upgradation of Dharmapuri – Madhugiri 765 kV line (presently charged at 400 kV) to its rated voltage at 765 kV alongwith 1x330 MVAR Switchable Line Reactor at Dharmapuri end of each circuit

The above transmission schemes have been forwarded to SRPC for views vide letter dated 10.07.2024. The transmission scheme was discussed and agreed in principally in the 52<sup>nd</sup> SRPC meeting held on 03.08.2024.

Sl. No.	Scope of the Transmission Scheme	Capacity /km
1.	Establishment of 3x1500 MVA, 765/400 kV Tuticorin (GH) S/s with 1x240 MVAR bus Reactor	<ul style="list-style-type: none"> <li>• 765/400kV, 1500 MVA, ICTs – 3 nos. (10x500 MVA incl. 1 spare unit)</li> <li>• 765kV ICT bays – 3 nos.</li> <li>• 400kV ICT bays – 3 nos.</li> </ul>

Sl. No.	Scope of the Transmission Scheme	Capacity /km
	<p><b>Future Space Provisions:</b></p> <ul style="list-style-type: none"> <li>• 765/400kV, 1500 MVA, ICTs – 3 nos.</li> <li>• 765kV ICT bays – 3 nos.</li> <li>• 400kV ICT bays – 3 nos.</li> <li>• 765kV line bays – 6 nos. (with provision for SLR)</li> <li>• 400kV line bays – 16 nos. (with provision for SLR)</li> <li>• 400kV Bus Sectionalizer : 1 set</li> </ul>	<ul style="list-style-type: none"> <li>• 765kV line bays – 2 nos. (at Tuticorin (GH) S/s for termination of Tuticorin (GH) – Tuticorin PS 765kV D/c line)</li> <li>• 765 kV, 240 MVA Bus Reactor – 1 nos. (4x80 MVA inc. 1 switchable spare unit)</li> <li>• 765 kV Bus Reactor bays – 1 nos.</li> </ul>
2.	Tuticorin PS – Tuticorin (GH) 765 kV D/c line	<p>~ 50 km</p> <ul style="list-style-type: none"> <li>• 765kV line bays – 2 nos. (at Tuticorin PS)</li> </ul>
3.	Upgradation of Tuticorin PS - Dharmapuri (Salem New) 765kV D/c line (presently charged at 400kV level) at its rated 765kV voltage level with 1x330 MVA switchable Line Reactor on both ends of each circuit	<ul style="list-style-type: none"> <li>• 765kV line bays Tuticorin PS – 2 nos.</li> <li>• 765 kV, 330 MVA SLR at Tuticorin PS – 2 nos. (7x110 MVA inc. 1 spare unit for both bus reactor and line reactor)</li> <li>• 765kV line bays at Dharmapuri (Salem New) – 2 nos.</li> <li>• 765 kV, 330 MVA SLR at Dharmapuri (Salem New) – 2 nos. (7x110 MVA inc. 1 spare unit for both bus reactor and line reactor)</li> </ul>
4.	Transmission line for change of termination from 400kV switchyard to 765kV switchyard for Tuticorin PS – Dharmapuri (Salem New) 765kV D/c line at Tuticorin PS & Dharmapuri (Salem New)	Approx. 1-2 kms at each end
5.	<p>Upgradation of Tuticorin PS to its rated voltage of 765kV level alongwith 3x1500 MVA, 765/400kV ICTs and 1x330 MVA, 765kV bus reactors</p> <p><b>Future Space Provisions:</b></p> <ul style="list-style-type: none"> <li>• 765/400kV, 1500 MVA, ICTs – 1 no.</li> <li>• 765kV ICT bays – 1 no.</li> <li>• 400kV ICT bays – 1 no.</li> <li>• 765kV line bays – 6 nos. (with provision for SLR)</li> </ul>	<ul style="list-style-type: none"> <li>• 765/400kV, 1500 MVA, ICTs – 3 nos. (10x500 MVA incl. 1 spare unit)</li> <li>• 765kV ICT bays – 3 nos.</li> <li>• 400kV ICT bays – 3 nos.</li> <li>• 765 kV, 330 MVA Bus Reactor – 1 nos.</li> <li>• 765 kV Bus Reactor bays – 1 nos.</li> </ul>
6.	<p>Upgradation of Dharmapuri (Salem New) to its rated voltage of 765kV level alongwith 3x1500 MVA, 765/400kV ICTs and 1x330 MVA, 765kV bus reactor</p> <p><b>Future Space Provisions:</b></p> <ul style="list-style-type: none"> <li>• 765/400kV, 1500 MVA, ICTs – 1 no.</li> <li>• 765kV ICT bays – 1 no.</li> <li>• 400kV ICT bays – 1 no.</li> <li>• 765kV line bays – 6 nos. (with provision for SLR)</li> </ul>	<ul style="list-style-type: none"> <li>• 765/400kV, 1500 MVA, ICTs – 3 nos. (10x500 MVA incl. 1 spare unit)</li> <li>• 765kV ICT bays – 3 nos.</li> <li>• 400kV ICT bays – 3 nos.</li> <li>• 765 kV, 330 MVA Bus Reactor – 1 nos. 765 kV Bus Reactor bays – 1 nos.</li> </ul>

Sl. No.	Scope of the Transmission Scheme	Capacity /km
7.	400 kV line reactors on Tuticorin PS - Dharmapuri (Salem New) 765kV D/c line shall be utilized as bus reactors at respective 400kV substations based on availability of bays.	
8.	Upgradation of Dharmapuri (Salem New) – Madhugiri 765kV 2xS/c lines (presently charged at 400 kV) to its rated voltage at 765 kV with 1x330 MVAR switchable Line Reactor on Dharmapuri (Salem New) end of each circuit	<ul style="list-style-type: none"> <li>• 765kV line bays at Dharmapuri (Salem New) – 2 nos.</li> <li>• 765 kV, 330 MVAR SLR at Dharmapuri (Salem New) – 2 nos. (6x110 MVAR switchable units)</li> <li>• 765kV line bays at Madhugiri – 2 nos.</li> </ul>
9.	Transmission line for change of termination from 400kV switchyard to 765kV switchyard for Dharmapuri (Salem New) – Madhugiri 765kV 2xS/c line at Dharmapuri (Salem New) & Madhugiri	Approx. 1-2 kms at each end
10.	400 kV line reactors on Dharmapuri (Salem New) – Madhugiri 765 kV 2xS/c lines shall be utilized as bus reactors at respective 400kV substations based on availability of bays.	

**Estimated cost : Rs. 2617 Crore**

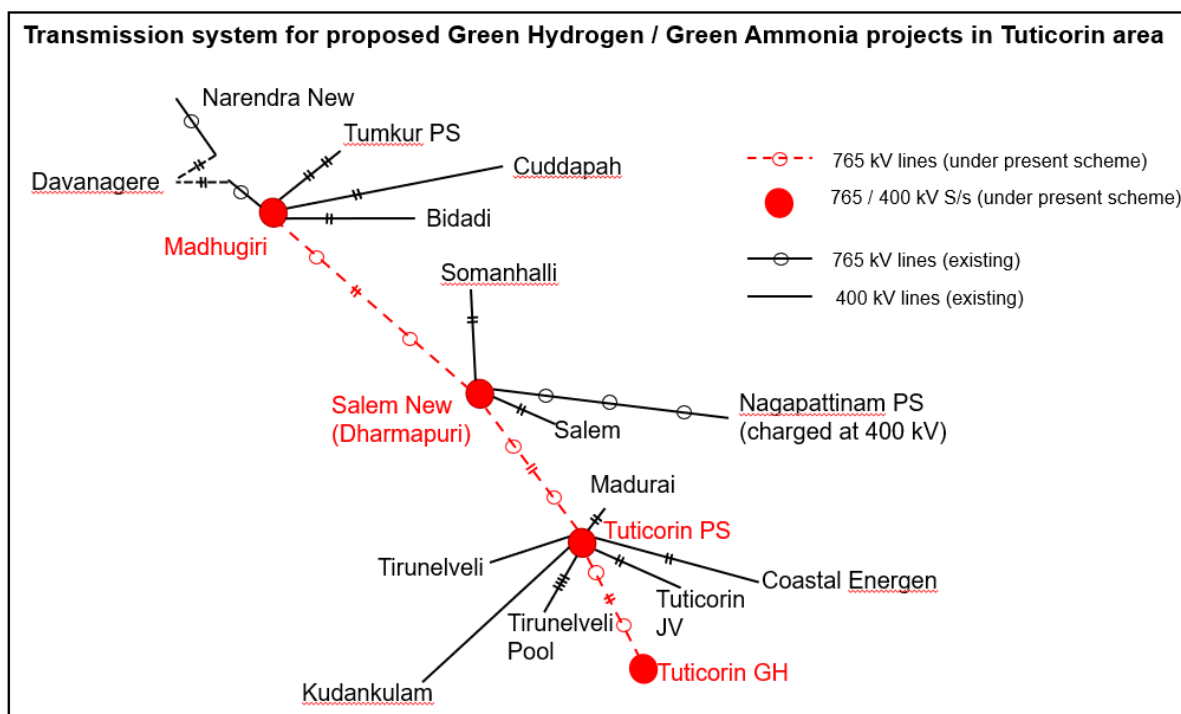

-X-X-X-